



**AMERICAN FORGE & FOUNDRY, INC.™**

## **1.5 TON / 2 TON / 3 TON ALUMINUM RACING JACKS**

**Models 206, 208, 210**

AFF's "1 - 2 - 3 - PUNCH" rounds out our Automotive Floor Jack lineup with a complete line of Aluminum Service Jacks - Lightweight, Rugged and Super Fast all three of these new models comes with a Double Pump Plunger design to get the car in the air and the job done quickly.

**206 - 1.5 Ton**



**208 - 2 Ton**

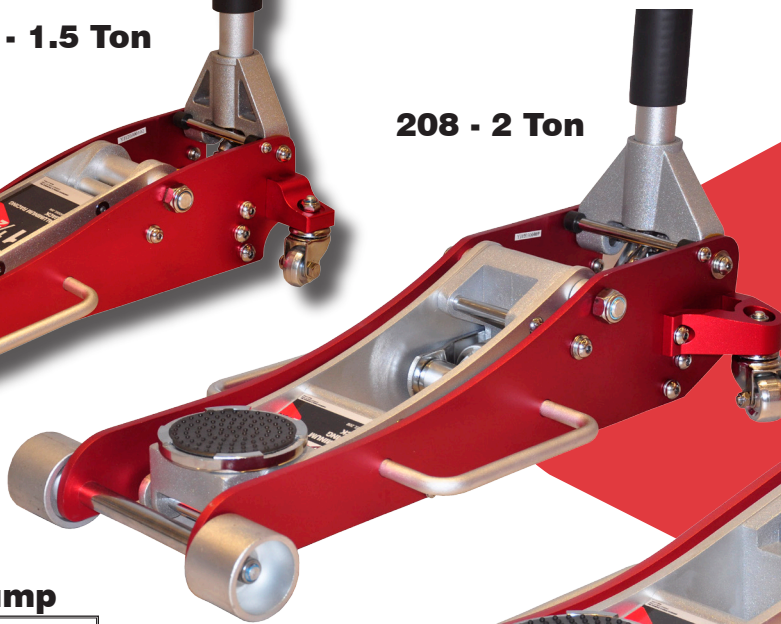

**210 - 3 Ton**

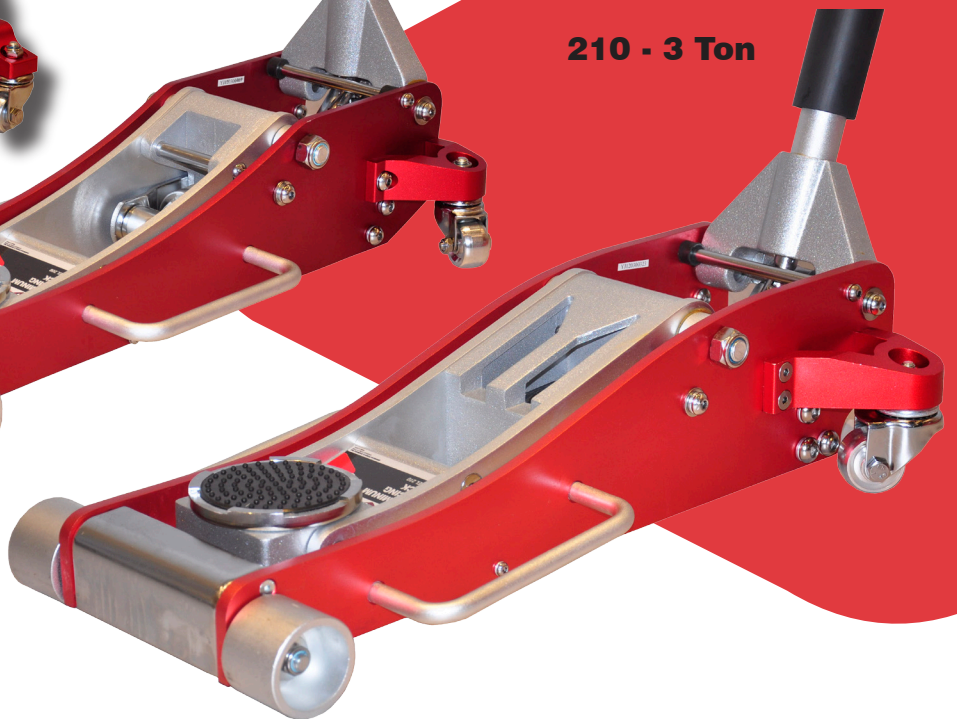

### **Double Pump**

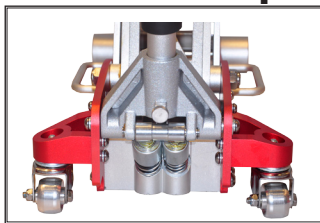

### **SPECIFICATIONS**

#### **Model 206 - 1.5 Ton Aluminum Racing Jack**

- Double Pump Design
- Padded 2 Pc. Handle
- Padded Saddle
- Side Handle
- Front Roller

Low Height ..... 3.25"  
 High Height ..... 15"  
 Length ..... 20.75"  
 Width (widest) ..... 10"  
 Net Weight ..... 26 lbs.  
 Gross Weight ..... 30 lbs.

#### **Model 208 - 2 Ton Aluminum Racing Jack**

- Double Pump Design
- Padded 2 Pc. Handle
- Padded Saddle
- 2 Side Handles
- Front Wheels

Low Height ..... 3.5"  
 High Height ..... 18.5"  
 Length ..... 25.75"  
 Width (widest) ..... 11.75"  
 Net Weight ..... 43 lbs.  
 Gross Weight ..... 46 lbs.

#### **Model 210 - 3 Ton Aluminum Racing Jack**

- Double Pump Design
- Padded 2 Pc. Handle
- Padded Saddle
- 2 Side Handles
- Front Wheels

Low Height ..... 3.75"  
 High Height ..... 19.3"  
 Length ..... 26"  
 Width (widest) ..... 14"  
 Net Weight ..... 55 lbs.  
 Gross Weight ..... 58 lbs.