

1/2" Drive Torx® Bit Sockets

- Heat-treated socket base for durability
- S2 steel insert bits offer maximum strength
- Double line (SAE) and knurled (metric) ring help easily identify standard and metric sockets
- Hard stamped size markings
- Bright, full polish chrome finish easily wipes clean and resists corrosion
- Meets or exceeds ASME specifications

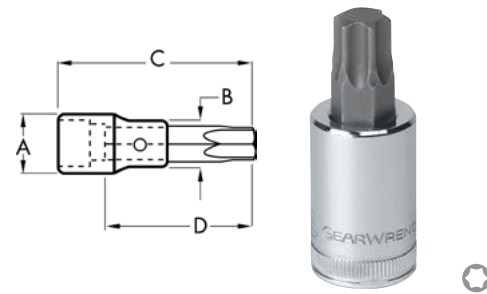

Cat. No.	Fastener Size	Dim. A: Drive End	Dim. B: Nose Diameter	Dim. C: Overall Length	Dim. D: Bit Length	Product Weight
80667	T60	0.944 in	0.944 in	2.48 in	1.49 in	0.30 lb

1/2" Drive Stubby Torx® Bit Sockets

- Reduced overall bit length provides better access in tight spaces
- Heat-treated socket base for durability
- S2 steel insert bits offer maximum strength
- Hard stamped size markings
- Bright, full polish chrome finish easily wipes clean and resists corrosion
- Meets or exceeds ASME specifications

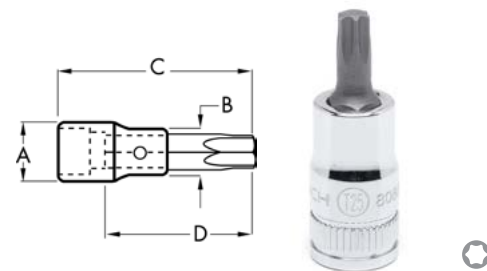

Cat. No.	Fastener Size	Dim. A: Drive End	Dim. B: Nose Diameter	Dim. C: Overall Length	Dim. D: Bit Length	Product Weight
80894	T55	0.858 in	0.700 in	2.15 in	1.181 in	0.16 lb
80896	T60	0.937 in	0.817 in	2.15 in	1.181 in	0.16 lb

1/2" Drive Tamper Proof Torx® Bit Sockets

- Heat-treated socket base for durability
- S2 steel insert bits offer maximum strength
- Double line (SAE) and knurled (metric) ring help easily identify standard and metric sockets
- Hard stamped size markings
- Bright, full polish chrome finish easily wipes clean and resists corrosion
- Meets or exceeds ASME specifications

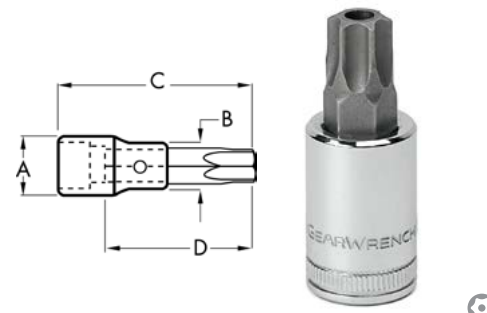

Cat. No.	Fastener Size	Dim. A: Drive End	Dim. B: Nose Diameter	Dim. C: Overall Length	Dim. D: Bit Length	Product Weight
80668	T60	0.944 in	0.944 in	2.48 in	1.49 in	0.30 lb

1/2" Drive External Torx® Sockets

- For use with external torx fasteners
- Black oxide finish is corrosion resistant
- Heat treated socket for durability
- Hard stamped size markings
- For use with manual drive tools only



Cat. No.	Fastener Size	Dim. A: Drive End	Dim. B: Nose Diameter	Dim. C: Overall Length	Product Weight
80669D	E18	0.944 in	0.944 in	1.5 in	0.30 lb
80670	E20	0.944 in	0.944 in	1.75 in	0.34 lb
80672	E22	1.125 in	1.125 in	2 in	0.36 lb
80673	E24	1.125 in	1.125 in	2 in	0.38 lb

27 Pc. 3/4" Drive 12 Point SAE Mechanics Tool Set

- 24 tooth full polish chrome quick-release ratchet
- Full polish chrome sockets with large hard-stamped size markings
- Knurled full polish chrome extensions
- Sockets feature off-corner loading design to reduce fastener rounding
- Includes metal box for storage and organization
- Meets or exceeds ASME specifications



Cat. No.	Included Storage	Product Weight
80880	Metal Box	26.40 lb

Cat. No.	Description	Cat. No.	Description
81400	3/4" Drive 24 Tooth Quick Release Teardrop Ratchet 19-3/4"	80841	3/4" Drive 12 Point Standard SAE Socket 1-3/8"
81404	3/4" Drive Breaker Bar 19"	80852	3/4" Drive 12 Point Standard SAE Socket 1-7/16"
81401	3/4" Drive Sliding T Handle 18"	80854	3/4" Drive 12 Point Standard SAE Socket 1-1/2"
81411	3/4" Drive Extension 5"	80855D	3/4" Drive 12 Point Standard SAE Socket 1-5/8"
81412	3/4" Drive Extension 8"	80856	3/4" Drive 12 Point Standard SAE Socket 1-11/16"
81413	3/4" Drive Extension 16"	80857	3/4" Drive 12 Point Standard SAE Socket 1-3/4"
80830	3/4" Drive 12 Point Standard SAE Socket 7/8"	80859	3/4" Drive 12 Point Standard SAE Socket 1-13/16"
80831	3/4" Drive 12 Point Standard SAE Socket 15/16"	80860	3/4" Drive 12 Point Standard SAE Socket 1-7/8"
80833	3/4" Drive 12 Point Standard SAE Socket 1"	80861	3/4" Drive 12 Point Standard SAE Socket 2"
80834	3/4" Drive 12 Point Standard SAE Socket 1-1/16"	80862	3/4" Drive 12 Point Standard SAE Socket 2-1/8"
80835D	3/4" Drive 12 Point Standard SAE Socket 1-1/8"	80863	3/4" Drive 12 Point Standard SAE Socket 2-3/16"
80838	3/4" Drive 12 Point Standard SAE Socket 1-3/16"	80864	3/4" Drive 12 Point Standard SAE Socket 2-1/4"
80839	3/4" Drive 12 Point Standard SAE Socket 1-1/4"	80865	3/4" Drive 12 Point Standard SAE Socket 2-3/8"
80840	3/4" Drive 12 Point Standard SAE Socket 1-5/16"		