

**HOLEMAKING & AUTO BODY
SOLUTIONS FOR THE PROFESSIONAL™**



NEW!



www.blairequipment.com

ROTABROACH® CUTTERS



Cut Holes 3x faster & lasts 10x longer than twist drills or hole saws

For precision holemaking in sheet metal and frame materials up to 1/2" thick. Blair Rotabroach Annular Cutters make clean, burr-free, round holes with no deforming of stock or damage to the surrounding material. Ideal for sheet metal fabrication or PDR and rustproofing access holes because the snap-in plugs fit perfectly. Custom builders and aftermarket equipment installers can also count on the superior quality holes.

Rotabroach Cutters are precision ground and made of M2 H.S.S. with a patented tooth geometry that also prevents chip clogging whether cutting steel, sheet metal or plastics. Unlike hole saws and twist drills that push and tear through materials, these cutters will make hundreds of holes with no deforming of stock, jagged edges or out-of-round holes.

Arbors for Rotabroach Cutters fit 3/8" and 1/2" hand held drill chucks and use either spring loaded pilots or skip-proof pilots which eliminate pre-drilling operations. Made in USA.

ARBORS

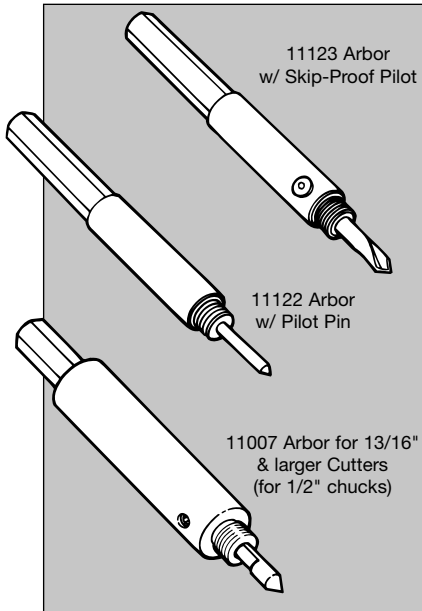

ARBORS

| Part Number | Description |
|----------------------------------|--|
| For 3/8" and larger drill chucks | |
| 11123 | Arbor w/ Skip-Proof Pilot for 3/8" (10mm) to 3/4" (20mm) Cutters |
| 11122 | Arbor w/ Pilot Pin for 1/4" (6mm) to 3/4" (20mm) Cutters |
| For 1/2" and larger drill chucks | |
| 11007 | Arbor for 13/16" to 1-1/2" Cutters |

PILOTS

| Part Number | Description |
|-------------|-----------------------------|
| 11097 | Pilot for 11123 Arbor (3pk) |
| 11121 | Pilot for 11122 Arbor (3pk) |
| 11628 | Pilot for 11007 Arbor (3pk) |

Kits available with popular sizes for general holemaking, PDR access holes, rustproofing, and spotweld removal. See Page 7.

| Diameter (Inches) | Decimal Equivalent | Part Number |
|--|--------------------|-------------|
| Use Arbor 11122 • 1/4" D.O.C. | | |
| 1/4 | .2500 | 11100-3 |
| 9/32 | .2812 | 11102-3 |
| 5/16 | .3125 | 11104-3 |
| 11/32 | .3438 | 11106-3 |
| Use Arbor 11122 or 11123 • 1/4" D.O.C. | | |
| 3/8 | .3750 | 11108-3 |
| 13/32 | .4062 | 11110-3 |
| 7/16 | .4375 | 11112-3 |
| 29/64 | .4531 | 11113-3 |
| 15/32 | .4688 | 11114-3 |
| 1/2 | .5000 | 11116-3 |
| 17/32 | .5312 | 11118-3 |
| 9/16 | .5625 | 11120-3 |
| 5/8 | .6250 | 11124-3 |
| 11/16 | .6875 | 11128-3 |
| 23/32 | .7188 | 11130-3 |
| 3/4 | .7500 | 11132-3 |
| Use Arbor 11007 • 1/2" D.O.C. | | |
| 13/16 | .8125 | 11336 |
| 7/8 | .8750 | 11340 |
| 15/16 | .9375 | 11344 |
| 1 | 1.0000 | 11348 |
| 1-1/16 | 1.0625 | 11352 |
| 1-1/8 | 1.1250 | 11356 |
| 1-3/16 | 1.1875 | 11360 |
| 1-1/4 | 1.2500 | 11364 |
| 1-5/16 | 1.3125 | 11365 |
| 1-3/8 | 1.3750 | 11366 |
| 1-7/16 | 1.4375 | 11367 |
| 1-1/2 | 1.5000 | 11368 |
| Diameter (Metric) | Decimal Equivalent | Part Number |
| Use Arbor 11122 • 1/4" D.O.C. | | |
| 6mm | .2362 | 11206-3 |
| 7mm | .2756 | 11207-3 |
| 8mm | .3150 | 11208-3 |
| 8.5mm | .3346 | 11285-3 |
| 9mm | .3543 | 11209-3 |
| Use Arbor 11122 or 11123 • 1/4" D.O.C. | | |
| 10mm | .3937 | 11210-3 |
| 11mm | .4331 | 11211-3 |
| 12mm | .4724 | 11212-3 |
| 13mm | .5118 | 11213-3 |
| 14mm | .5512 | 11214-3 |
| 15mm | .5906 | 11215-3 |
| 16mm | .6299 | 11216-3 |
| 17mm | .6693 | 11217-3 |
| 18mm | .7087 | 11218-3 |
| 19mm | .7480 | 11219-3 |
| 20mm | .7874 | 11220-3 |

All cutters ending in (-3) are sold as a 3 pack.

STEP DRILLS

- Premium Cobalt M42 for long tool life
- Faster starting with Blair split point
- Angled double flute for faster penetration
- TiN coated for increased tool life & improved hole quality

| Part Number | Description | Depth |
|-------------|---------------|-------|
| 35400 | 1/8" to 1/2" | 1/8" |
| 35401 | 3/16" to 1/2" | 3/8" |
| 35402 | 3/16" to 7/8" | 1/8" |



SPOTWELD DRILL

Remove Spotwelds Fast on All Types of Metals

- Low Speed 800 RPM - Better for UHSS & Boron
- Manual Feed w/ Leverage Handle Increases Cutter Performance (No air power is consumed to advance the cutter, resulting in more torque and faster spotweld removal)
- Adjustable Cutting Depth
- Two 360° Swivel Frame Clamps (Included)
 - 2-5/16" and 5-5/8" depth
- Low Noise
- Built in Comfort Grip
- Includes (1) 8mm Triple-Fluted Solid Carbide Drill Bit
- Additional Sizes of Carbide Spotweld Drills
 - Part No. 11306 (6.5mm)
 - Part No. 11308 (8mm)
 - Part No. 11310 (10mm)
 - Part No. 11312 (12mm)

Specifications

| | |
|------------------|-------------------|
| Cutter RPM: | 800 |
| Air Pressure: | 90 psi |
| Air Consumption: | 4 CFM (113 L/min) |
| Length: | 13-15/16" (346mm) |
| Height: | 9-1/4" (235mm) |
| Width: | 2" (50mm) |
| Weight: | 5.5 lbs (2.5 kg) |
| Noise Level: | 84dB |



Part No. 11300

Patented



PREMIUM SOLID SPOTWELD CUTTERS



Drill out Boron spotwelds fast with the Premium Solid Spotweld Cutter. Made from solid carbide for long tool life in today's high strength, extremely hard body panels. Designed for use on UHSS, Boron and standard automotive steels. It is self centering and has an easy cutting action, leaving no damage to underlying panels. Double coated for maximum durability. For use with the Blair Enforcer™ Spotweld Drill or "gun" type spotweld tools. Made in USA.



| Diameter | Part Number |
|----------|-------------|
| 6.5mm | 11306 |
| 8mm | 11308 |
| 10mm | 11310 |
| 12mm | 11312 |

PREMIUM SPOTWELD CUTTERS

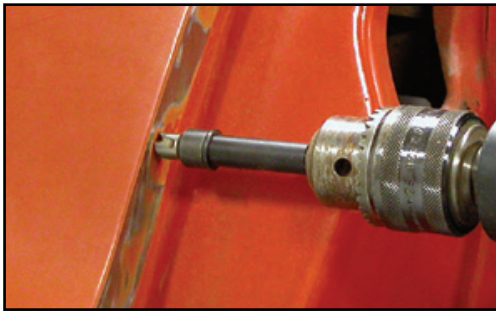

When you have a lot of spotwelds to remove, step up to the Premium Spotweld Cutters for longer life in auto body repair and restoration. These cutters have a heavier wall (.090") for extreme durability and two step geometry that splits the chips and helps clear them. Premium Spotweld Cutters have a fast cutting action and lasts for hundreds of spotwelds. They are for use in 3/8" or larger drill chucks. The spotweld cutters are available individually or in kits containing 3 cutters. (See page 7 for Spotweld Kits). Made in USA.

11093 Replacement Parts: Arbor - 11123, Pilot - 11097

11094 Replacement Parts: Arbor - 11122, Pilot - 11121

3/8" Premium Spotweld Replacement Cutters
Part No. 11108-3



Two types to choose from:

Premium Spotweld Cutter w/ Standard Pilot
Part No. 11094



Skip-Proof Premium Spotweld Cutter
Part No. 11093

BLAIR SPOTWELD CUTTER



3/8" Double-End Replacement Spotweld Cutters Part No. 13214



Blair Double-End Spotweld Cutters make removing body panels fast and easy. Their hollow design cuts around the spotweld so weld hardness does not affect tool sharpness. When one end becomes dull, simply unscrew the cutter and flip it over using the new teeth on the other side. An adjustable depth rod sets the tool so only the outer panel is cut, leaving the underlying panel undamaged. Made in USA. Replacement Parts: Arbor - 13216, Pilot - 13217.

Blair Double-End Spotweld Cutter
Part No. 13224





Low Cost Sheet Metal Holemaking

When you don't have a lot of holes to make, Blaircutters provide fast, accurate holes in materials up to 3/16" thick. Blaircutters are annular cutting tools that cut around the edge of the hole and eject the center as a slug. Because they're hollow there's no dead zone as with twist drills. And unlike hole saws, that rip and tear through the material, they quickly give you a quality, virtually burr-free hole. Blaircutters are available in seven sizes for 1/4" and larger drill chucks. Spring loaded pilot "pops" the slug from the cutter. Made in USA.

Blaircutters are sold in 3 packs and are available in a kit Part No. 13218

BLAIRCUTTER®

| Diameter (Inches) | Decimal Equivalent | Part Number |
|-------------------|--------------------|-------------|
| 3/16" D.O.C. | | |
| 1/4 | .2500 | 13200 |
| 5/16 | .3125 | 13202 |
| 3/8 | .3750 | 13204 |
| 7/16 | .4375 | 13206 |
| 1/2 | .5000 | 13208 |
| 9/16 | .5625 | 13210 |
| 5/8 | .6250 | 13212 |

Arbor & Pilot

| Part Number | Description |
|-------------|---|
| 13216 | 1/4" Blaircutter Arbor w/ retractable pilot |
| 13217 | Pilots - 3 Pack |



Carbide Holcutters cut smooth, fast, burr-free holes in all types of materials, from soft aluminum to tough-to-cut stainless and cast iron, up to 1/8" thick. Dramatically outlasts bi-metal hole saws and step drills. (All cutters include arbor, pilot and spring.)

HOLCUTTER™

| Diameter (Inches) | Decimal Equivalent | Part Number |
|--|--------------------|-------------|
| Replacement Pilot (14701) Spring (14703) | | |
| 11/16 | .6875 | 14722 |
| 3/4 | .7500 | 14724 |
| 13/16 | .8125 | 14726 |
| 7/8 | .8750 | 14728 |
| 15/16 | .9375 | 14730 |
| 1 | 1.0000 | 14732 |
| 1-1/16 | 1.0625 | 14734 |
| 1-1/8 | 1.1250 | 14736 |
| 1-3/16 | 1.1875 | 14738 |
| 1-1/4 | 1.2500 | 14740 |
| 1-5/16 | 1.3125 | 14742 |
| 1-3/8 | 1.3750 | 14744 |

| Diameter (Inches) | Decimal Equivalent | Part Number |
|--|--------------------|-------------|
| 1-1/2 | 1.5000 | 14748 |
| 1-5/8 | 1.6250 | 14752 |
| 1-3/4 | 1.7500 | 14756 |
| 2 | 2.0000 | 14762 |
| 2-1/8 | 2.1250 | 14766 |
| 2-1/4 | 2.2500 | 14768 |
| 2-3/8 | 2.3750 | 14772 |
| Replacement Pilot (14702) Spring (14704) | | |
| 2-1/2 | 2.5000 | 14774 |
| 2-5/8 | 2.6250 | 14778 |
| 2-3/4 | 2.7500 | 14780 |
| 3 | 3.0000 | 14784 |



For large holemaking in sheet metal and other materials up to 1/8" thick.

Made from high speed steel with precision cutting teeth, lasts **3x** longer and cuts **10x** faster than bi-metal hole saws or twist drills. All cutters use a single arbor, with a patented Quad-Lead thread mounting system (sold Separately). Made in USA.

Holcutter Kit contains six popular sizes of cutters... Part No.14006

| Diameter (Inches) | Decimal Equivalent | Part Number |
|-------------------------------|--------------------|-------------|
| Use Arbor 14609 • 1/8" D.O.C. | | |
| 11/16 | .6875 | 14622 |
| 3/4 | .7500 | 14624 |
| 13/16 | .8125 | 14626 |
| 7/8 | .8750 | 14628 |
| 15/16 | .9375 | 14630 |
| 1 | 1.0000 | 14632 |
| 1-1/16 | 1.0625 | 14634 |
| 1-1/8 | 1.1250 | 14636 |
| 1-3/16 | 1.1875 | 14638 |
| 1-1/4 | 1.2500 | 14640 |
| 1-5/16 | 1.3125 | 14642 |
| 1-3/8 | 1.3750 | 14644 |
| 1-7/16 | 1.4375 | 14646 |
| 1-1/2 | 1.5000 | 14648 |
| 1-9/16 | 1.5625 | 14650 |
| 1-5/8 | 1.6250 | 14652 |
| 1-11/16 | 1.6875 | 14654 |
| 1-3/4 | 1.7500 | 14656 |
| 1-7/8 | 1.8750 | 14660 |
| 2 | 2.0000 | 14662 |

| Diameter (Inches) | Decimal Equivalent | Part Number |
|-------------------|--------------------|-------------|
| 2-1/16 | 2.0625 | 14664 |
| 2-1/8 | 2.1250 | 14666 |
| 2-1/4 | 2.2500 | 14668 |
| 2-3/8 | 2.3750 | 14672 |
| 2-1/2 | 2.5000 | 14674 |
| 2-9/16 | 2.5625 | 14676 |
| 2-5/8 | 2.6250 | 14678 |
| 2-3/4 | 2.7500 | 14680 |
| 2-7/8 | 2.8750 | 14682 |
| 3 | 3.0000 | 14684 |

Arbors & Pilots

| Part Number | Description |
|-------------|---|
| 14609 | Arbor for Quad-Lead Holcutter w/ washer & pilot |
| 14601 | Arbor for 11/16" - 1-5/16" Old Style Holcutter |
| 14604 | Arbor for 1-3/8" - 3" Old Style Holcutter |
| 14610 | Pilot for 14609 arbor |
| 14611 | Hex Washer for 14609 arbor |
| 11097 | Pilot for 14601 Arbor |
| 13306 | Pilot for 14604 Arbor |

PAINT SHAKER

Part No. 51000 (120V)
51100 (230V)

Blair Tornado II™, The Truly Portable Paint Shaker That Doesn't Need To Be Bolted Down.

Blair Tornado II™ Paint Shakers can be set on a work bench without being bolted down thanks to its unique design.

- The Tornado II mixes paints completely utilizing three axis of motion, including orbital, side-to-side, and up/down.
- To achieve these multiple motions, the portable shaker spins an eccentric weight rather than using crankshafts, belts, or pulleys which can wear out and break.
- Lightweight at only 24 lbs (10.9 kg).
- Made in USA.

You can use Blair Tornado II Paint Shakers anywhere* it's convenient to mix gallons, quarts, pints, or aerosols.

- The fewer moving parts also minimizes noise while the paint shaker is in operation.
- A quick and easy to use four point clamping system that securely holds containers during mixing.
- Blending cycles can be set to numerous time intervals via the convenient up-front control panel.
- One year warranty
- 26" H x 15-3/8" W x 11-1/2" D (660mm H x 391mm W x 292mm D)
- Can/Paint weight limit: 11 lbs (5kg)



| Part Number | Description |
|-------------|---|
| 51027 | Upper Set of (4) Springs |
| 51028 | Lower Set of (4) Springs |
| 51032 | Top Hold Down Knob |
| 00980 | Hold Down Kit (Sidebar, Screw Assy & Top Bar) |

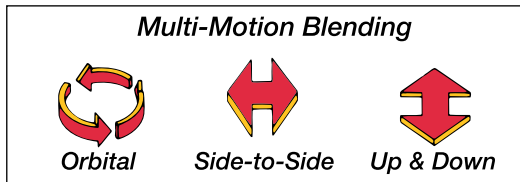

*Tornado II is not explosion proof. Do not use in areas that could be hazardous.

ACCESSORIES

Flanger



Part No. 13229



- Now with 50% additional clearance for producing a radius.
- Repairs made in half the time with absolutely no stretching or distortion of material.
- Makes a perfect joint even through underbody deadener in sculptured contours and high crowns.
- No need to remove parts of the vehicle - with the Blair Flanger, all work is performed from one side.
- Lightweight 7" cam action flanger springs open for quick release and position of next compression.
- Made in USA.

Rotabroach® Stick Lubricant



Part No. 11750

Convenient 1.68 oz. tube is ideal for sheet metal hole cutters. Softer than standard stick lubricants, it provides superior adhesion to the tool and can be used in place of cutting fluids with ferrous and non-ferrous metals, to increase tool life, improve cutting performance, & easier slug removal. Made in USA.

CUTTER KITS



Rotabroach® Cutter Kit

| Part Number | Description |
|----------------|---|
| 11090 | 5/16, 3/8, 7/16, 1/2, 9/16, 5/8, & 3/4" Cutters, Arbor (11122), Hex Wrench, Center Punch, & Extra Pilot |
| 11092 (Metric) | 8, 10, 12, 14, 16, 18, & 20mm Cutters, Arbor (11122), Hex Wrench, Center Punch, & Extra Pilot |
| 11099 | 16 sizes (1/4 - 3/4") Cutters, Arbor (11122), Hex Wrench, Center Punch, & Extra Pilot |
| 11201 (Metric) | 16 sizes (6mm - 20mm) Cutters, Arbor (11122), Hex Wrench, Center Punch, & Extra Pilot |



Rotabroach® Large Diameter Cutter Kit

| Part Number | Description |
|-------------|---|
| 11091 | 7/8, 1, 1-1/8, 1-1/4, 1-3/8, & 1-1/2" Cutters, Arbor (11007), Hex Washer, Center Punch, & Extra Pilot |



Rotabroach® Combo Cutter Kit

| Part Number | Description |
|-------------|---|
| 11320 | Combines the 11090 & 11091 into one kit. Contains 13 different sizes of cutters, (2) arbors, extra pilots, center punch & hex wrench. |



Holcutter™ Kit

| Part Number | Description |
|-------------|---|
| 14006 | 7/8, 1-1/8, 1-3/8, 1-3/4, 2, 2-1/2" Cutters, Arbor, Hex Washer, & Extra Pilot |
| 14003 | 3/4, 1, & 1-1/4" Cutters, Arbor & Extra Pilot Drills |



Spotweld Cutter Kits

| Part Number | Description |
|-------------|--|
| 11082 | (3) 3/8" Cutters, Arbor (11122) w/ Standard Pilot & Extra Pilot |
| 11096 | (3) 3/8" Cutters, Arbor (11123) w/ Skip-Proof Pilot, & Extra Pilot |
| 11098 | (3) 5/16" Cutters, Arbor (11122) w/ Standard Pilot & Extra Pilot |



Rustproof/PDR Kits

| Part Number | Description |
|-------------|---|
| 11080 | 1/4, 3/8, 1/2, & 3/4" Cutters, Arbor w/ Standard Pilot, & Extra Pilot |
| 11081 | (3) 1/2" Cutters, Arbor (11122) w/ Standard Pilot, & Extra Pilot |
| 11095 | (3) 1/2" Cutters, Arbor (11123) w/ Skip-Proof Pilot, & Extra Pilot |



Blaircutter® Kit

| Part Number | Description |
|-------------|---|
| 13218 | 1/4, 5/16, 3/8, 7/16, 1/2, 9/16 & 5/8" Cutters, Arbor, & (3) Extra Pilots |



Blair body shop tools are used by collision and custom shops around the world to make auto body repairs, aftermarket installations, and custom fabrication easier, faster, more accurate and more profitable. No matter if its Rotabroach® Cutters, Holcutter™, or Spotweld Cutters, Blair makes holes faster and with superior quality. Make body repairs that exceed those off the assembly line, keeping with the high standards of today's automotive market.

The world of custom hotrods and motorcycles is bigger than ever and whether you're a top fabricator or weekend warrior, you need the tools to express your creativity. Blair tools can help turn those ideas into a reality. Holemaking in sheet metal has never been easier. Plus, use the Blair Flanger to make perfect overlapping joints to weld panels, or the Tornado II Portable Paint Shaker to mix your paint to the right consistency.

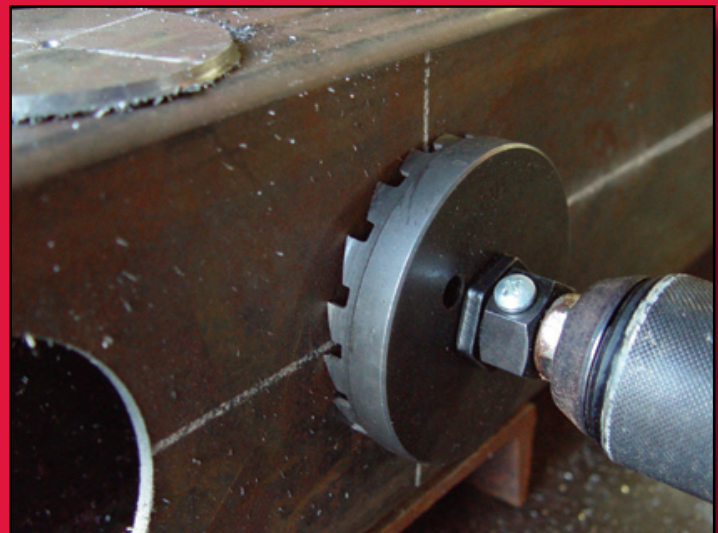

WARRANTY

Blair Equipment Company warrants its paint shaker for one (1) full year and all other products for ninety (90) days from the date of purchase against defects due to faulty material or workmanship and will repair or replace (at its option) without charge any items returned. This warranty is void if the item has been damaged by accident or unreasonable use, neglect, improper maintenance, service, or other causes not arising out of defects in material or workmanship. No other expressed warranty is given or authorized. Blair Equipment Company disclaims any implied warranty of MERCHANTABILITY or FITNESS for any period beyond the expressed warranty and shall not be liable for incidental or consequential damages. Some states do not allow exclusion of incidental or consequential damages or limitation on how long an implied warranty lasts and if the law of such a state governs your purchase, the above exclusion and limitation may not apply to you. This warranty gives you specific legal rights and you may also have other rights which vary from state to state.

For Warranty Service, return all products, transportation prepaid to:
Blair Equipment Company
3001 Hougen Drive
Swartz Creek, Michigan 48473

THE ABOVE WARRANTY IS IN LIEU OF ANY OTHER WARRANTY, EXPRESSED OR IMPLIED, INCLUDING ANY WARRANTY OF MERCHANTABILITY OR FITNESS FOR A PARTICULAR PURPOSE.

Blair products are covered under one or more of the following patents: 4,952,102; 5,145,296; 5,624,213.

Blair™

Blair Equipment Company
P.O. Box 2005 • Flint, MI 48501-2005
Phone: 810-635-7111 • Fax: 810-635-8277
E-mail: info@blairequipment.com
Online: www.blairequipment.com

Distributed By:

