

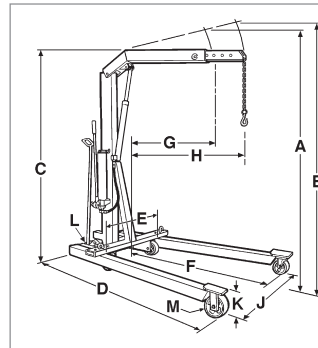

1819, 1820



Specifications	1819	1820
Cap., boom retracted	2,200	4,400
Cap., boom extended	1,650	3,300
A Max. boom height, boom retracted	107"	111"
B Max. boom height, boom extended	117"	122"
C Overall height, boom horizontal	80"	82"
D Overall length	83"	89"
E Minimum throat width	24"	25"
F Inside leg length	54"	57-1/2"
G Effective boom reach (retracted)	33"	35-1/2"
H Effective boom reach (extended)	48"	50-1/2"
J Inside leg width (3-position)	24", 36" 48"	26", 40" 52-1/2"
K Leg height	8"	9-1/2"
L Dolly wheel diameter	5"	5"
M Wheel diameter	6"	8"
Height, folded	79"	86"
1819 Floor space folded	27" x 38"	
1820 Floor space folded	31" x 42"	

2,200 and 4,400 lb. Capacity Heavy-Duty Floor Cranes

- To conserve valuable floor space, crane folds into a compact package for storage.
- For "close-in" work, leg spread adjusts to clear vehicle's wheels, telescoping boom extension gives additional reach. Roller bearing mounted wheels and steering dolly provide ease of mobility.
- A two-speed hydraulic hand pump provides fast boom travel; descent of boom is under precise control of operator.
- Covered by OTC Lifetime Warranty®.

1819 2,200 lb. Capacity Crane. Has hydraulic hand pump and 16-7/8" lifting chain.

39610 1/4" steel chain grade 43, 18-3/8" long, 2,200 lb. capacity. Has safety hook on end. Use with 1819.

1820 4,400 lb. Capacity Crane. Has hydraulic hand pump and 18-3/8" lifting chain.

39611 5/16" steel chain grade 70, 19-3/4" long, 4,400 lb. capacity. Has safety hook on end. Use with 1820.



1813

Boom Capacity (lbs.) Description	Extended 4,000	Centered 5,000	Retracted 6,000
A Maximum boom height	161-7/8"	150-11/16"	139-1/2"
B Minimum boom height	6"	17-3/8"	28-3/4"
C Overall height (boom horizontal)	87"	87"	87"
D Overall length*	129-1/8"	113-7/8"	98-1/4"
E Inside leg length	91-11/16"	76-1/8"	43-1/4"
F Effective boom horizontal reach	94-1/4"	78-3/4"	63-1/4"
G Outside leg width**	59-3/4"	57-3/4"	55-3/4"
H Boom swing	36"	31"	26"
J Inside leg width	35-3/4"		
K Leg height	9-1/16"		
M Wheel diameter	8"		
Dolly wheel diameter	5"		

* Legs in storage position: 80-7/8"

** Legs in storage position: 53-1/2"

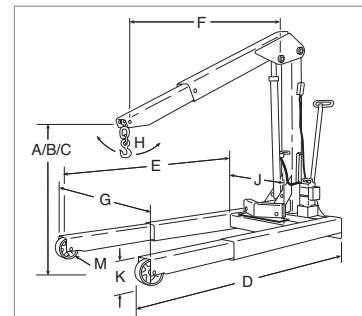

6,000 lb. Capacity Heavy-Duty Mobile Floor Cranes

- Three boom positions give capacities of 4,000, 5,000, and 6,000 lbs. to handle the biggest engines, and often the transmission right along with the engine! Usable reach is almost 92".
- Boom swivels for vertical and lateral positioning; legs extend to straddle the biggest tires.

1814 6,000 lb. capacity crane with electric/ hydraulic pump (115V) with remote motor control.

1813 6,000 lb. capacity crane with two-speed hydraulic hand pump.



1819, 1820

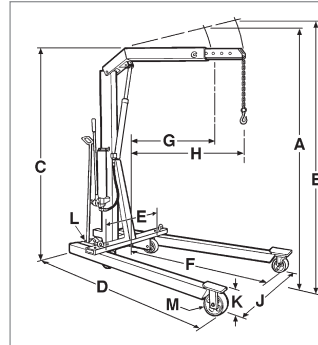

2,200 and 4,400 lb. Capacity Heavy-Duty Floor Cranes

- To conserve valuable floor space, crane folds into a compact package for storage.
- For "close-in" work, leg spread adjusts to clear vehicle's wheels, telescoping boom extension gives additional reach. Roller bearing mounted wheels and steering dolly provide ease of mobility.
- A two-speed hydraulic hand pump provides fast boom travel; descent of boom is under precise control of operator.
- Covered by OTC Lifetime Warranty®.

1819 2,200 lb. Capacity Crane. Has hydraulic hand pump and 16-7/8" lifting chain.

39610 1/4" steel chain grade 43, 18-3/8" long, 2,200 lb. capacity. Has safety hook on end. Use with 1819.

1820 4,400 lb. Capacity Crane. Has hydraulic hand pump and 18-3/8" lifting chain.

39611 5/16" steel chain grade 70, 19-3/4" long, 4,400 lb. capacity. Has safety hook on end. Use with 1820.

Specifications	1819	1820
Cap., boom retracted	2,200	4,400
Cap., boom extended	1,650	3,300
A Max. boom height, boom retracted	107"	111"
B Max. boom height, boom extended	117"	122"
C Overall height, boom horizontal	80"	82"
D Overall length	83"	89"
E Minimum throat width	24"	25"
F Inside leg length	54"	57-1/2"
G Effective boom reach (retracted)	33"	35-1/2"
H Effective boom reach (extended)	48"	50-1/2"
J Inside leg width (3-position)	24", 36", 48"	26", 40", 52-1/2"
K Leg height	8"	9-1/2"
L Dolly wheel diameter	5"	5"
M Wheel diameter	6"	8"
Height, folded	79"	86"
1819 Floor space folded	27" x 38"	
1820 Floor space folded	31" x 42"	



1813

Boom Capacity (lbs.)	Extended	Centered	Retracted
Description	4,000	5,000	6,000
A Maximum boom height	161-7/8"	150-11/16"	139-1/2"
B Minimum boom height	6"	17-3/8"	28-3/4"
C Overall height (boom horizontal)	87"	87"	87"
D Overall length*	129-1/8"	113-7/8"	98-1/4"
E Inside leg length	91-11/16"	76-1/8"	43-1/4"
F Effective boom horizontal reach	94-1/4"	78-3/4"	63-1/4"
G Outside leg width**	59-3/4"	57-3/4"	55-3/4"
H Boom swing	36"	31"	26"
J Inside leg width	35-3/4"		
K Leg height	9-1/16"		
M Wheel diameter	8"		
Dolly wheel diameter	5"		

* Legs in storage position: 80-7/8"

** Legs in storage position: 53-1/2"

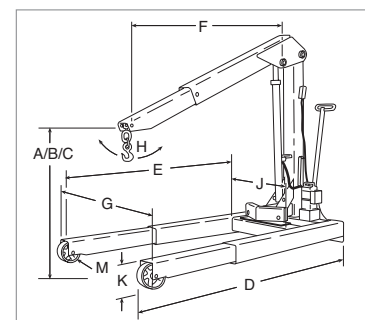

6,000 lb. Capacity Heavy-Duty Mobile Floor Cranes

- Three boom positions give capacities of 4,000, 5,000, and 6,000 lbs. to handle the biggest engines, and often the transmission right along with the engine! Usable reach is almost 92".
- Boom swivels for vertical and lateral positioning; legs extend to straddle the biggest tires.

1814 6,000 lb. capacity crane with electric/ hydraulic pump (115V) with remote motor control.

1813 6,000 lb. capacity crane with two-speed hydraulic hand pump.