

CPS[®]

A/C SOLVENT FLUSH **(For use with CPS SUPER FLUSH SOLVENT)**



OPERATION MANUAL

AFM100 SERIES FLUSH UNIT

Table of Contents

Specifications.....	2
Introduction.....	3
General Safety Instructions.....	4
Unit Layout.....	5
Solvent Flush Operation.....	6
Maintenance.....	7
Warranty and Contact Info.....	8

AFM100 Specifications

Unit Consists Of:	Set of universal clamps, service hoses and an operational manual
Power Source	50 PSIG minimum air pressure
Dimensions	21.5" wide x 18.5" deep x 39.4" high
Weight	78 lbs
Operating Range	0° C (32°F) to 49° C (120°F)
Air Pressure Gauge	0 to 100 PSIG
Filtration	100 mesh cleanable screen
Manual Control Valves	2 way ball type valve to control air supply to the unit 3 way ball type valve to control air Purge / Flush circulation 4 way ball type valve to control Forward and Reverse flush
Construction	Heavy duty power coated sheet metal cabinet with 6" wheels
Adaptors	One set of universal clamps with 3/8" SAE Male fittings
High Pressure Relief Valve	125 PSIG
Solvent	CPS Super Flush: AFMSF (One Gallon Can) AFMSFC (Case of 4 Gallon Cans)

INTRODUCTION

Thank you for purchasing the CPS Pro-Set® AFM100 series A/C solvent flush unit. CPS is dedicated to provide the most reliable equipment to meet all your mobile A/C service requirements.

The AFM100 is designed for flushing individual or combinations of components of a mobile air conditioning system. Simply add CPS Super Flush (CPS p/n AFMSF, AFMSFC) to the holding tank, connect universal clamps to the component and connect compressed shop air to the unit. Follow the instructions in this manual for effective flush methods.

The Pro-Set® AFM100 series Solvent flush unit does not require reconnection of hoses for reverse flushing. A control valve will allow the user to reverse the flow at any time. The CPS Universal Flush clamps makes connecting to an A/C component easy.

The following are additional features:

- One set of CPS Universal Flush Clamps
- Easy one step hook up Air Hose and Flush Hoses
- Forward / Reverse flush valve to eliminate reconnection of hoses
- Filter with clear removable bowl for flow and filtration verification
- Large mouth flush fill tube
- Heavy duty powder coated steel cabinet with 6" wheels
- Storage area for 2 one gallon flush containers

To help you get a good start, please continue to carefully read the balance of this manual. This manual contains important information on the proper procedures for operating this equipment. Please pay close attention to the safety information, Warnings, and Cautions provided throughout this manual. Always remember "**Safety First**".

TO BE OPERATED BY QUALIFIED PERSONNEL ONLY

GENERAL SAFETY INSTRUCTIONS

Only qualified service personnel should operate this unit. Most states, countries, etc... may require the user to be licensed. Please check with your local government agency.

DANGER- the flush tank fill CAP is under pressure. Remove the pressure from flush tank before removing fill cap by putting the PURGE / FLUSH valve to the PURGE position and making sure the pressure gauge reads 0 before removing the tank fill cap.

CAUTION- all hoses may contain solvent under pressure. Wear proper personal protective equipment such as safety goggles and gloves. When disconnecting any hose, please use extreme caution.

CAUTION- avoid breathing solvent vapor fumes. Exposure may irritate eyes, nose, throat, and skin. Please read the manufacturers material safety data sheet for further safety information on the solvent.

CAUTION- avoid skin contact with solvent. Exposure may irritate eyes, nose, throat, and skin. Please read the manufacturers material safety data sheet for further safety information on the solvent. Wear proper personal protective equipment such as safety goggles and gloves. When disconnecting any hose, please use extreme caution.

CAUTION- make sure flush collection tank is drained after each usage. Failure to do so will result in solvent being spilled on the floor.

CAUTION- keep solvent and solvent mist way from heat, sparks and flame. The solvent is combustible.

Use only CPS solvent AFMSF with this unit. Using other types of solvent will void the warranty of this unit.

UNIT LAYOUT

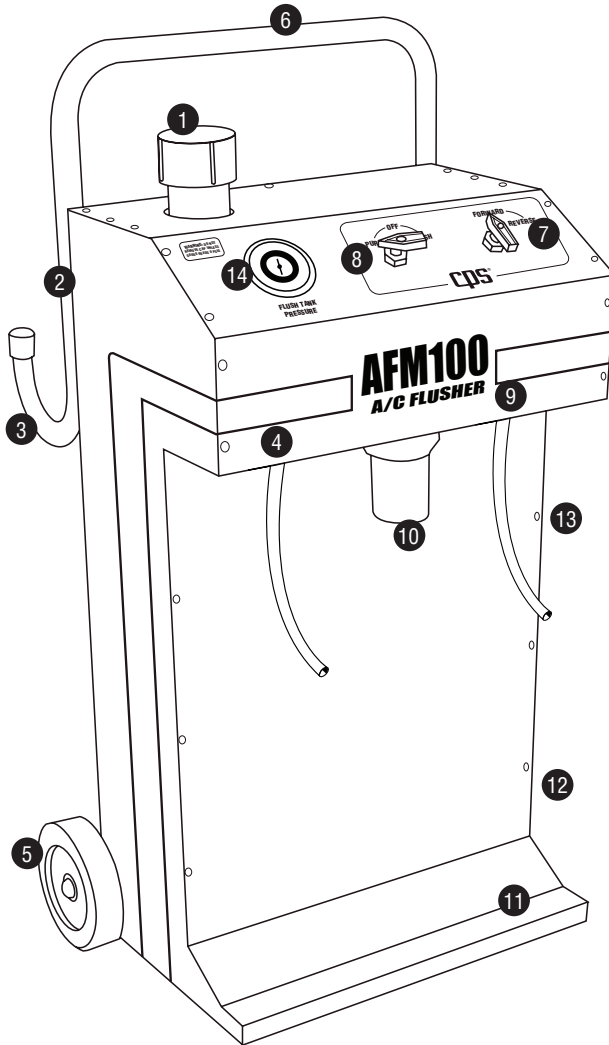

Unit Guide:

1. Flush tank fill cap
2. Air supply inlet port and ball valve
(back side of unit not shown)
3. Hose storage hooks
4. Outlet Hose A
(to component out fitting)
5. 6" wheels
6. Handle
7. Flow direction valve
8. Flush valve
9. Outlet Hose B (to component out fitting)
10. Clear bowl with cleanable filter
11. Storage shelf
12. Collection tank drain valve
(back side of unit not shown)
13. Collection tank sight glass
(right side of unit not shown)
14. Flush tank pressure gauge

AFM100 OPERATION

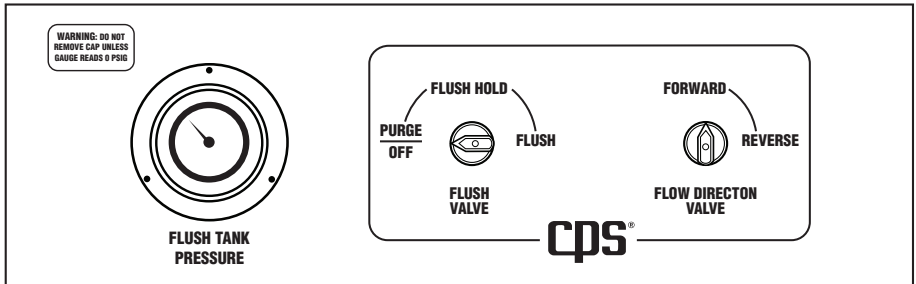

Initial Preparation:

1. Open drain valve on the back of the unit to empty **Collection Tank**. This will prevent overfilling of the collection tank which will lead to spillage of spent solvent. Check sight glass for solvent level in the collection tank.
2. **DO NOT** connect an air supply hose to the unit at this time. **CAUTION: The pressure gauge must read 0 PSIG before removing the tank fill cap.** If pressure exists close **AIR SUPPLY** valve and turn **FLUSH VALVE** to **PURGE/OFF** position. This will relieve the pressure in the Flush Tank.
3. Remove the flush tank Fill Cap by hand only. Add amount of CPS solvent to be flushed through the A/C component. Maximum capacity of flush tank is 2.5 gallons. See following chart for flush amount to used:

RECOMMENDED FLUSH SOLVENT AMOUNT PER VEHICLE:

CAR/PICKUP TRUCKS:	2 Quarts
DUAL AIR SYSTEMS:	3 Quarts
HEAVY DUTY TRUCKS:	3 Quarts
BUSES/MOBILE HOMES etc:	up to 2 Gallons

4. Once flush tank is filled to the desired amount with CPS solvent, reinstall cap. Make sure the cap is hand tight. **DO NOT USE A WRENCH TO TIGHTEN FILL CAP.**

Purge or Flow Verification Procedure:

1. Connect **OUTLET HOSE A** via connectors*/adaptors to the outlet of the component to be flushed.
2. Connect **INLET HOSE B** via connectors*/adaptors to the inlet of the component to be flushed. ***CPS provides a set of Universal Clamps for this purpose. There maybe other type of connectors or adaptors required.**

3. Turn **FLUSH VALVE** to **PURGE/OFF** position. Turn **FLOW DIRECTION VALVE** to **FORWARD** position.
4. Connect shop air hose to **COMPRESSED AIR INLET PORT** located on the back of the unit.
5. Open the **AIR SUPPLY VALVE** on the back of the unit.
6. Verify air flow by checking the air vent on the back of the unit. Air should be felt coming out of this port. If no flow, turn the **FLOW DIRECTION VALVE** to **REVERSE** position turn. If there is still no air flow, the component may be permanently plugged.
7. Once air flow is confirmed in either direction, proceed to flush procedure.

Flush Procedure:

1. With the **FLOW DIRECTION VALVE** in the position of verified flow, turn **FLUSH VALVE** to **FLUSH** position. The CPS solvent is now being pushed through the component.
2. Monitor the Clear Bowl and both flush hoses. Once CPS solvent is present in both hoses and is seen moving through the bowl, turn the **FLUSH VALVE** to **FLUSH HOLD** position.
3. Hold for **10-15 minutes**. This allows the CPS solvent to dissolve contaminants.
4. Turn **FLUSH VALVE** back to **FLUSH** position. Run for 1-2 minutes or until all the solvent has passed through the component.
5. To **REVERSE FLUSH**, turn the **FLOW DIRECTION VALVE** to opposite position used during flush. Run until solvent is gone.

Air Drying Procedure:

1. Turn the **FLUSH VALVE** to **PURGE/OFF** position. Turn the **FLOW DIRECTION VALVE** to the **FORWARD** position. Let air run through component for 5-10 minutes to evaporate remaining solvent
2. Once air drying procedure is complete, close the **AIR SUPPLY VALVE**. Make sure air pressure gauge reads zero before disconnecting flush hose to component.

Open Drain on the back of the unit to drain spent solvent. Dispose of solvent per local, state, and/or federal requirements.

MAINTENANCE / PARTS LIST

Filter Element Cleaning:

After each use it will be necessary to clean the filter element contained in the Clear Bowl.

Clean as follows:

1. Make sure air hose is disconnected and air pressure on gauge reads zero. If pressure exists, turn **PURGE / FLUSH** valve to **PURGE** position. This will vent the air pressure in the flush tank.
2. Unscrew bowl from filter housing.
3. Remove cylindrical filter. Clean filter element with clean solvent or blow out with shop air.
4. Reinstall filter element and secure by screwing clear bowl back onto the filter housing.

Check the universal flush clamp for worn seals. Check hoses for worn seals.

THE FOLLOWING ARE SERVICEABLE PARTS FOR THE AFM100 UNIT:

CPS Part Number	Description
AFMXH	Flush hose with 3/8 female SAE swivel connection
AFMXHS	Flush hose rubber seal, set of 2
AFMXF	Replacement cylindrical filters
AFMXC	Replacement universal clamp complete
AFMXCS	Replacement universal clamp rubber seal
AFMXR	Replacement Refill Cap

THE FOLLOWING ARE PART NUMBERS FOR THE CPS SUPER FLUSH

CPS Part Number	Description
AFMSF	One gallon can of CPS Super Flush
AFMSFC	One case 4-One gallon cans of CPS Super Flush

WARRANTY / CONTACT INFORMATION

WARRANTY & REPAIR POLICY

CPS Products, Inc. guarantees that all products are free of manufacturing and material defects to the original owner for one year from the date of purchase. If the equipment should fail during the guarantee period it will be repaired or replaced (at our option) at no charge. This guarantee does not apply to equipment that have been altered, misused or solely in need of field service maintenance. All repaired equipment will carry an independent 90-day warranty. This repair policy does not include equipment that is determined to be beyond economical repair.

CPS Products, Inc. (World Headquarters)

1010 East 31st Street, Hialeah, Florida 33013, USA
Tel: 305-687-4121, 1-800-277-3808, Fax: 305-687-3743
E-mail: info@cpsproducts.com
Website: www.cpsproducts.com

CPS Canada LTD.

1324 Blundell Road, Mississauga, Ontario L4Y 1M5
Tel: 905-615-8620, Fax: 905-615-9745
E-mail: info@cpsproducts.com

CPS Products N.V

Krijgsbaan 241, 2070 Zwijndrecht, Belgium
Tel: (323) 281 30 40, Fax: (323) 281 65 83
E-mail: info@cpsproducts.be
Website: www.cpsproducts.be

CPS Australia PTY. LTD.

109 Welland Avenue, Welland, South Australia 5007
Tel: +61 8 8340 7055, Fax: +61 8 8340 7033
E-mail: sales@cpsaustralia.com.au

CPS ASIA

87 Bukit Timah Road, Unit B2, Singapore 229834
Tel: (65) 63375691, Fax: (65) 63375692
E-mail: cpsasia@singnet.com.sg

cps[®]

www.cpsproducts.com

#73-065 Rev. B