

# TEKNA® Basecoat

## THE ULTIMATE BASECOAT SPRAY GUN



### Includes:

- HV20 HVLP Air Cap
- Extra needle/nozzle set
- Digital gauge with air adjusting valve (HAV-555)
- Gun wrench and color ID rings



Waterborne compatible when using a plastic or disposable cup system.



Order No.	Fluid Tips	Cup	Air Caps
703892*	1.2, 1.3mm	Uncupped	HV20 (HVLP)
703893*	1.3, 1.4mm	Uncupped	HV20 (HVLP)
703894	1.2, 1.3mm	900cc Aluminum	HV20 (HVLP)
703895	1.3, 1.4mm	900cc Aluminum	HV20 (HVLP)

\* Uncupped guns include disposable cups adapter

### TEKNA® Basecoat Air Caps

HV20 air cap (HVLP)	Solvent and waterborne basecoats	Air Cap Pattern
Air Cap Order/Model No	703899	12½"
Fluid Tips	11.2–13 CFM @ 14–18 PSI inlet	
Fluid Tips	1.2mm, 1.3mm, 1.4mm, 1.5mm	



Refer to Technical Bulletin: TB-1018

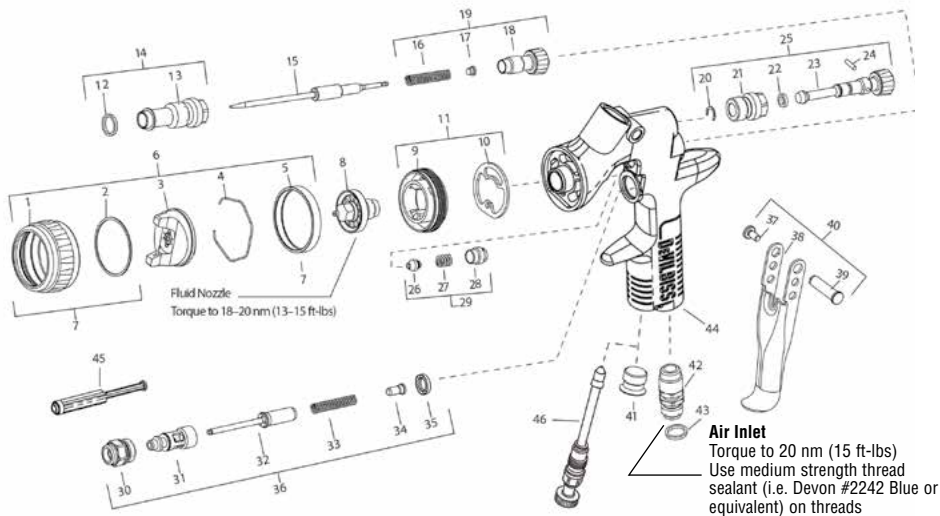

### CHART 1 Air Cap Replacement Parts

Air Cap Order No.	Application	Air Cap No.	Recommended Inlet Pressure BAR/PSI	Air Flow LPM/SCFM
703899	Basecoats	HV20	1.2–1.3 bar 14–18 psi	317–368 LPM 11.2–13.0 CFM

### CHART 2 Fluid Nozzles

Fluid Nozzle Order No.	No. on Fluid Nozzle	Tip Size (mm)
702711	SN-37-11	1.1
702712	SN-37-12	1.2
702713	SN-37-13	1.3
702714	SN-37-14	1.4
702715	SN-37-15	1.5

Wrench (10 & 14mm)	702740
Seal and Pin Kit, kit of 5 (items 20, 22 and 24)	192229

\* The TEKNA Spray Gun Repair Kit (702736) contains all the parts indicated with an asterisk.

Ref #	Description	Part #	Qty
1	Air Cap Retaining Ring		1
2	Slip Ring		1
3	Air Cap		1
4	Air Cap Retaining Clip	191972	1
5	Retaining Ring Seal		1
6	Air Cap & Ring	Chart 1	1
7	Air Cap Retaining Ring & Seals	703896	1
8	Fluid Nozzle	Chart 2	1
9	Air Separator		1
*10	Air Separator Seal (kit of 2)	702726	1
11	Air Separator & Seal Kit	703900	1
*12	Body Bushing Gasket		1
13	Body Bushing		1
14	Body Bushing & Gasket	702728	1
15	Fluid Needle	Chart 2	1
*16	Needle Spring		1
*17	Needle Spring Pad		1
18	Fluid Adjusting Knob		1
19	Fluid Adjusting Knob, Spring, & Pad Kit	703897	1
*20	Retaining Clip		1
21	Spreader Valve Body		1
*22	O-ring		1
23	Spreader Valve Adjusting Knob		1
*24	Spreader Valve Pin		1
25	Spreader Valve Assembly	703898	1
*26	Needle Packing		1
*27	Packing Spring		1
*28	Packing Nut		1
29	Packing, Spring & Packing Nut Kit	702731	1
30	Air Valve Body		1
31	Air Valve Cage		1
32	Air Valve Poppet		1
33	Air Valve Spring		1
34	Air Valve Spring Pad		1
35	Air Valve Seal		1
36	Air Valve Assembly	702732	1
*37	Trigger Stud Screw (T20 Star)		1
38	Trigger		1
*39	Trigger Stud		1
40	Trigger, Stud & Screw Kit	702733	1
41	Plug		1
42	Air Inlet	702734	1
43	Colour ID Ring Kit (4 Colours)	702735	1
44	Gun Body		1
45	Air Valve Service Tool (only included with Air Valve Assembly 36)		1
46	Air Adjusting Valve (optional)	702737	1

# TEKNA® Copper HE BASECOAT/CLEARCOAT GRAVITY FEED SPRAY GUNS



**Includes:**

- 7E7 high efficiency air cap
- HAV-555 air adjusting valve with digital gauge
- Extra needle/nozzle set
- Gun wrench and color ID rings

EPA and SCAQMD Approved

EPA Compliant. Approved in most HVLP areas.

Waterborne compatible when using a plastic or disposable cup system.

Order No.	Needle/Nozzle	Cup	Air Cap
703675*	1.2mm, 1.3mm	Uncupped	7E7
703676	1.2mm, 1.3mm	900cc Aluminum	7E7
703661*	1.3mm, 1.4mm	Uncupped	7E7
703662	1.3mm, 1.4mm	900cc Aluminum	7E7

\* Uncupped guns include disposable cups adapter

**TEKNA® Copper HE Air Caps**

Air Cap	Application	Air Cap Order/Model No.	Air Cap Pattern
#7E7 air cap (HE)	Basecoats, clearcoats	703062	12½"
#202 air cap (HVLP)	Basecoats (solvent)	702723	13"
#909 air cap (HVLP)	Clearcoats, waterborne basecoats	702724	12"

**Fluid Tips**  
1.1mm, 1.2mm, 1.3mm, 1.4mm, 1.5mm (for hot climate waterborne)



Refer to Technical Bulletin: TB-1016

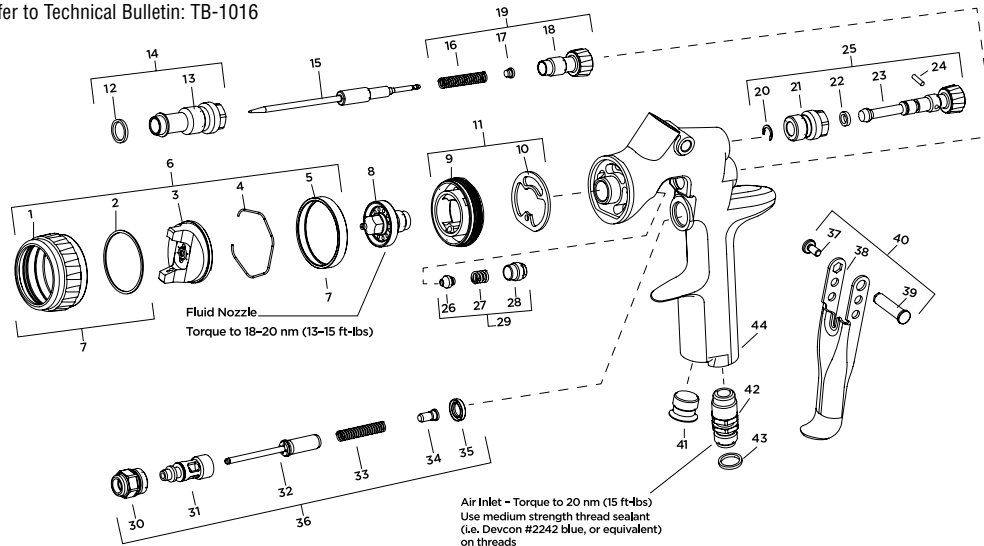

**CHART 1: Fluid Nozzle & Fluid Needle Replacement Parts**

Fluid Nozzle Size I.D. (mm)	Fluid Nozzle/Needle Set No.	Part No.	Qty
1.1	702711	1	1
1.2	702712	2	1
1.3	702713	3	1
1.4	702714	4	1
1.5	702715	5	1

**NOTE:** When replacing the fluid nozzle or fluid needle, replace both at the same time. Lightly lubricate the threads of the fluid nozzle before reassembling. Torque 14-16 nm (10-12 ft-lbs). Don't over tighten the fluid nozzle. Use 10mm wrench supplied with gun.

**CHART 2: Air Cap Replacement Parts**

Air Cap Order No.	Application	Air Cap No.	Recommended Inlet Pressure BAR/PSI	Air Flow LPM/SCFM
702723	Basecoats	#202 HVLP	1.2-1.5 BAR/18-22 PSI	382-434 LPM 13.5-15.5 SCFM
702724	Clearcoats Waterborne Base	#909 HVLP	1.5-1.8 BAR/22-26 PSI	396-453 LPM 14-16 SCFM
703062	Basecoats, clearcoats	#7E7 HE	1.1-1.5 BAR/16-22 PSI (HVLP approved areas) 1.5-2.0 BAR/22-30 PSI (non-HVLP approved areas)	255-312 LPM/9-11 SCFM 312-368 LPM/11-13 SCFM (non-HVLP approved areas)

Ref. No.	Description	Part No.	Qty
1	Air Cap Retaining Ring		1
2	Slip Ring		1
3	Air Cap		1
4	Air Cap Retaining Clip	191972	1
5	Retaining Ring Seal		1
6	Air Cap & Ring (see Chart 2)		1
7	Air Cap Retaining Ring & Seals	702725	1
8	Fluid Nozzle (see Chart 2)		1
9	Air Separator		1
*10	Air Separator Seal (kit of 2)	702726	1
11	Air Separator & Seal Kit	702727	1
*12	Body Bushing Gasket		1
13	Body Bushing		1
14	Body Bushing & Gasket	702728	1
15	Fluid Needle (see Chart 1)		1
*16	Needle Spring		1
*17	Needle Spring Pad		1

Ref. No.	Description	Part No.	Qty
18	Fluid Adjusting Knob		1
19	Fluid Adjusting Knob, Spring, & Pad Kit	702729	1
*20	Retaining Clip		1
21	Spreader Valve Body		1
*22	O-ring		1
23	Spreader Valve Adjusting Knob		1
*24	Spreader Valve Pin		1
25	Spreader Valve Assembly	702730	1
*26	Needle Packing		1
*27	Packing Spring		1
28	Packing Nut		1
29	Packing, Spring & Packing Nut Kit	702731	1
30	Air Valve Body		1
31	Air Valve Cage		1
32	Air Valve Poppet		1
33	Air Valve Spring		1
34	Air Valve Spring Pad		1
35	Air Valve Seal (kit of 5)	803307	1
36	Air Valve Assembly	702732	1
*37	Trigger Stud Screw (T20 Star)		1
38	Trigger		1
*39	Trigger Stud		1
40	Trigger, Stud & Screw Kit	702733	1
41	Plug		1
42	Air Inlet	702734	1
43	Colour ID Ring Kit (4 Colours)	702735	1
44	Gun Body		1

\* The TEKNA Spray Gun Repair Kit (702736) contains all the parts indicated with an asterisk.

**OTHER SALABLE PARTS /ACCESSORIES**

Wrench (10 & 14mm)	702740
#202 Test Cap (HVLP)	702738
#909 Test Cap (HVLP)	702739
Spray Gun Repair Kit	702736
TEKNA Replacement 900cc Aluminum Cup	702576
Disposable Lid Kit (2)	GFC-404-K2
Paint Filter Kit	KGP-5-K5