

# StartingLine® HVLP Auto Painting GUN KITS



## Specifications

### Finish Coat & Primer Gun

30 PSI inlet pressure delivers 10 PSI air cap pressure at 13 CFM air volume

### Detail Gun

30 PSI inlet pressure delivers 10 PSI air cap pressure at 8 CFM air volume

### All Guns

Air inlet: 1/4" NPS

Order No.	Kit	Guns Included	Fluid Tip (mm)	Cup(s) Included	Accessories Included
802342	2-Gun Painting & Touch Up	Finish Coat Detail	1.3 1.0 1.8	One 600cc (20 oz.) One 250cc (8.5 oz.)	Cleaning brushes, wrench, air adjusting valve with gauge
802343	2-Gun Painting & Priming	Finish Coat Primer	1.3 1.5 1.8	Two 600cc (20 oz.)	Cleaning brushes, wrench, air adjusting valve with gauge
802789	3-Gun Painting	Finish Coat Primer Detail	1.3 1.8 1.0	Two 600cc (20 oz.) One 130cc (4 oz.)	Cleaning brushes, wrench, air adjusting valve with gauge
803485	2-Gun Primer Pack	Primer (2)	1.5 1.8	Three 3 oz. plastic, four 24 oz. liners & lids, one, frame/lid, two plugs	Extra 1.5 tip & needle, (2) DPC-81 adapters, wrench, filter, funnel
802405	Detail Gun only		1.0	One 250cc (8.5 oz.)	None



HVLP Finish Coat Spray Gun



HVLP Primer Spray Gun



HVLP Detail Spray Gun



2-Gun Primer Pack

Detail gun also sold separately

Refer to Service Bulletins: SB-2-634, SB-2-610 and SI-2-61-10

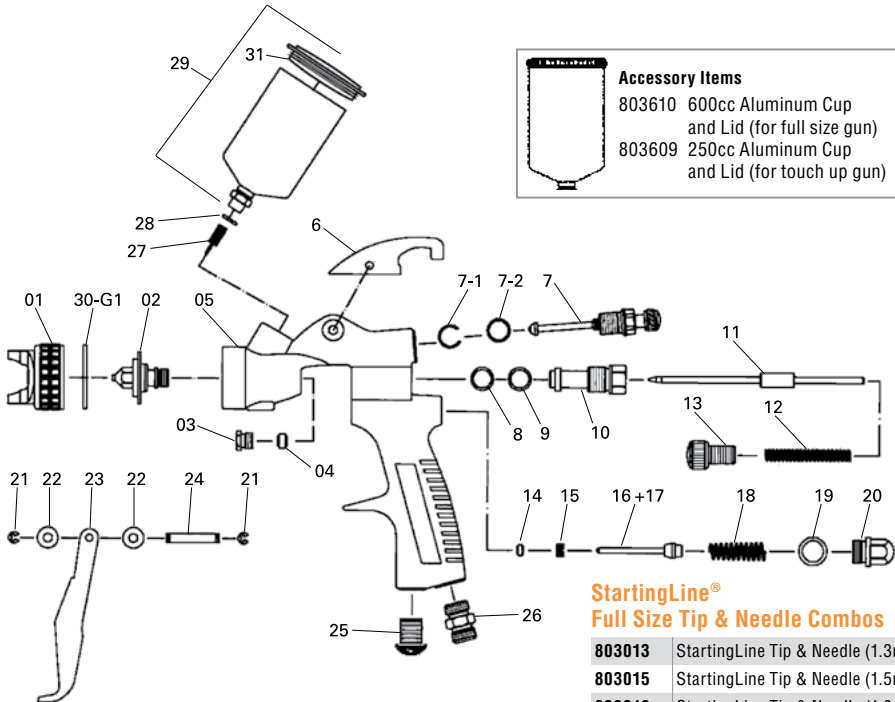

### StartingLine® Full Size Tip & Needle Combos

- 803013 StartingLine Tip & Needle (1.3mm)
- 803015 StartingLine Tip & Needle (1.5mm)
- 803018 StartingLine Tip & Needle (1.8mm)

- Gun Repair Kit Full Size (802425) Touchup (802426)
- ▲ Cup Fitting Gasket Kit Full Size and Touchup (803615)

Ref. No.	Part No.	Description	Ind. Parts Req.
1	—	Air Cap W/Ring	1
2	—	Fluid Nozzle	1
●3	—	Nut	1
●4	—	Gasket	1
5	—	Gun Body	1
6	—	Hook	1
7	—	Fan Control	1
●7-1	—	C-Clip	2
●7-2	—	O-Ring	2
●8	—	Gasket	1
●9	—	O-Ring	1
10	—	Housing	1
11	—	Paint Needle	1
●12	—	Spring	1
13	—	Knob, Fluid Control	1
●14	—	Gasket	1
●15	—	Screw	1
●16+17	—	Valve Stem Complete	1
●18	—	Spring	1
●19	—	O-Ring	1
20	—	Air Valve Nut	1
●21	—	E-Ring	2
22	—	Washer	2
23	—	Trigger	1
●24	—	Trigger Stud	1
25	—	Plug	1
26	—	Air Inlet Fitting	1
27	—	Filter	1
●▲28	—	Gasket for Fitting	2
29	803610	600cc Alum. Cup & Lid	1
	803609	250cc Alum. Cup & Lid	1
●30-G1	—	Gasket for Air Cap	1
31	803591	600cc Push-In Lid	2
	803590	250cc Push-In Lid	2

## Gravity Feed Cups

**Cups to fit DeVilbiss, Binks, FinishLine, and TEKNA Gravity Spray Guns**

Order No.	Model No.	Cup Size	Application
190252	GFC-501	20 oz. Acetal	All full size current DeVilbiss, TEKNA, Binks and FinishLine gravity guns
901430	81-381	8 oz. Aluminum	DeVilbiss SRI, SRIW, SRIPro, and Binks Cub gravity guns
900875	54-4458	4 oz. Aluminum	DeVilbiss SRI, SRIW, SRIPro, and Binks Cub gravity guns
192191	SRI-478-K12	4 oz. Nylon	DeVilbiss SRI, SRIW, SRIPro, and Binks Cub gravity guns
702576	702576	900cc Aluminum	All full-size current DeVilbiss, TEKNA, Binks and FinishLine gravity guns
803510	DPC-503-K24	3 oz. Plastic	Fits on all DPC adapters



GFC-501

702576

81-381

SRI-478-K12

DPC-503-K24

54-4458

## StartingLine Gravity Feed Cups

Order No.	Cup Size	Application
803610	600cc Aluminum	StartingLine Finish Coat and Primer gravity guns
803609	250cc Aluminum	StartingLine Detail gravity guns
803591	600cc Aluminum	Push-in lids (2)
803590	250cc Aluminum	Push-in lids (2)



803610

803609

803590

803591

## E-Z Liners

**Most Economical Disposable Paint Cup System Available**

- Saves time with easy clean up and less mess
- Saves money by greatly reducing solvent use for clean up

Order No.	Model No.	Description
190966	OMX-70-K48	E-Z Liner Kit (48 liners & bushings)

