



HK-150 (HK1058)

Installation Tool
Instruction Manual



CONTENTS

SAFETY	4
PRINCIPLE OF OPERATION	5
TOOL SPECIFICATIONS	5
OPERATING INSTRUCTIONS	6 - 7
RIVET PINTAIL REMOVAL	7
JAW INSTALLATION AND REMOVAL	8 - 9
TOOL MAINTENANCE	10
TROUBLESHOOTING	11
OPTIONAL ACCESSORIES	12
RIVETER TO NUTSETTER CONVERSION INSTRUCTIONS	13
90 DAY WARRANTY	14
AUTHORIZED TOOL SERVICE CENTER	14



SAFETY

This instruction manual must be read, with particular attention to the following safety guidelines, by any person servicing or operating this tool.

1. Glossary



— Read manual prior to using equipment.



— Eye protection required while using this equipment.



— Hearing protection required while using this equipment.



WARNINGS - Must be understood to avoid severe personal injury.



CAUTIONS - show conditions that will damage equipment and or structure.

Notes - are reminders of required procedures.

Bold, Italic type and underlining - emphasizes a specific instruction.

2. A half hour long hands-on training session with qualified personnel is recommended before using Huck equipment.
3. Huck equipment must be maintained in a safe working condition at all times. Tools and hoses should be inspected at the beginning of each shift/day for damage or wear. Any repair should be done by a qualified repairman trained on Huck procedures.
4. Repairman and Operator must read manual prior to using equipment. Warning and Caution stickers/labels supplied with equipment must be understood before connecting equipment to any primary power supply. As applicable, each of the sections in this manual have specific safety and other information.
5. Read MSDS Specifications before servicing the tool. MSDS Specifications are available from the product manufacturer or your Huck representative.
6. When repairing or operating Huck installation equipment, always wear approved eye protection. Where applicable, refer to ANSI Z87.1 - 2003
7. Disconnect primary power source before performing maintenance on Huck equipment or changing Nose Assembly.
8. Tools and hoses should be inspected for leaks at the beginning of each shift/day. If any equipment shows signs of damage, wear, or leakage, do not connect it to the primary power supply.
9. Mounting hardware should be checked at the beginning of each shift/day.
10. Make sure proper power source is used at all times.
11. Release tool trigger if power supply is interrupted.
12. Tools are not to be used in an explosive environment unless specifically designed to do so.
13. Never remove any safety guards or pintail deflectors.
14. Ensure deflector or pintail collector is installed and operating prior to use.
15. Never install a fastener in free air. Personal injury from fastener ejecting may occur.
16. Always clear spent pintail out of nose assembly before installing the next fastener.
17. There is possibility of forcible ejection of pintails or spent mandrels from front of tool.
18. If there is a pinch point between trigger and work piece, use remote trigger. (Remote triggers are available for all tooling).
19. Unsuitable postures may not allow counteracting of normal expected movement of tool.
20. Do not abuse tool by dropping or using it as a hammer. Never use hydraulic or air lines as a handle or to bend or pry the tool. Reasonable care of installation tools by operators is an important factor in maintaining tool efficiency, eliminating downtime, and in preventing an accident which may cause severe personal injury.
21. Never place hands between nose assembly and work piece. Keep hands clear from front of tool.
22. There is a risk of crushing if tool is cycled without Nose Assembly installed.
23. Tools with ejector rods should never be cycled with out nose assembly installed.
24. When two piece lock bolts are being used always make sure the collar orientation is correct. See fastener data sheet of correct positioning.
25. There is a risk of whipping compressed air hose if tool is pneudraulic or pneumatic.
26. Tool is only to be used as stated in this manual. Any other use is prohibited.



PRINCIPLE OF OPERATION

READ INSTRUCTIONS THOROUGHLY PRIOR TO OPERATING THE RIVETER. THIS RIVETER IS DESIGNED FOR INTERMITTENT DUTY AND MAINTENANCE WORK ONLY.

The HK-150 is a hydraulic tool designed to set from 1/8 inch up to and including 1/4 inch diameter steel, stainless steel, aluminum and plastic rivets by changing only the nose piece. The HK-150 has a rated pull pressure of over 3,500 lbs and one handed operation gives access to tight areas.

The hydraulic system is sealed, oil cannot be added. If the HK-150 should become damaged and leaks oil from the tool, **it should be returned to an authorized service center.**

TOOL SPECIFICATIONS

Operating Temperature Range: 32 ° - 125 ° F (0 ° - 51.7 ° C)

Maximum Operating Temperature: 125 ° F (51.7 ° C)

STROKE	RIVET DIAMETER	RIVET MATERIALS	PULL PRESSURE	WEIGHT
5/8" (1.58 cm)	1/8"-1/4" (.32-.63 cm)	Stainless Steel, Aluminum, Plastic	3,500 lbs (15.6 kN)	28 oz (.79 kg)

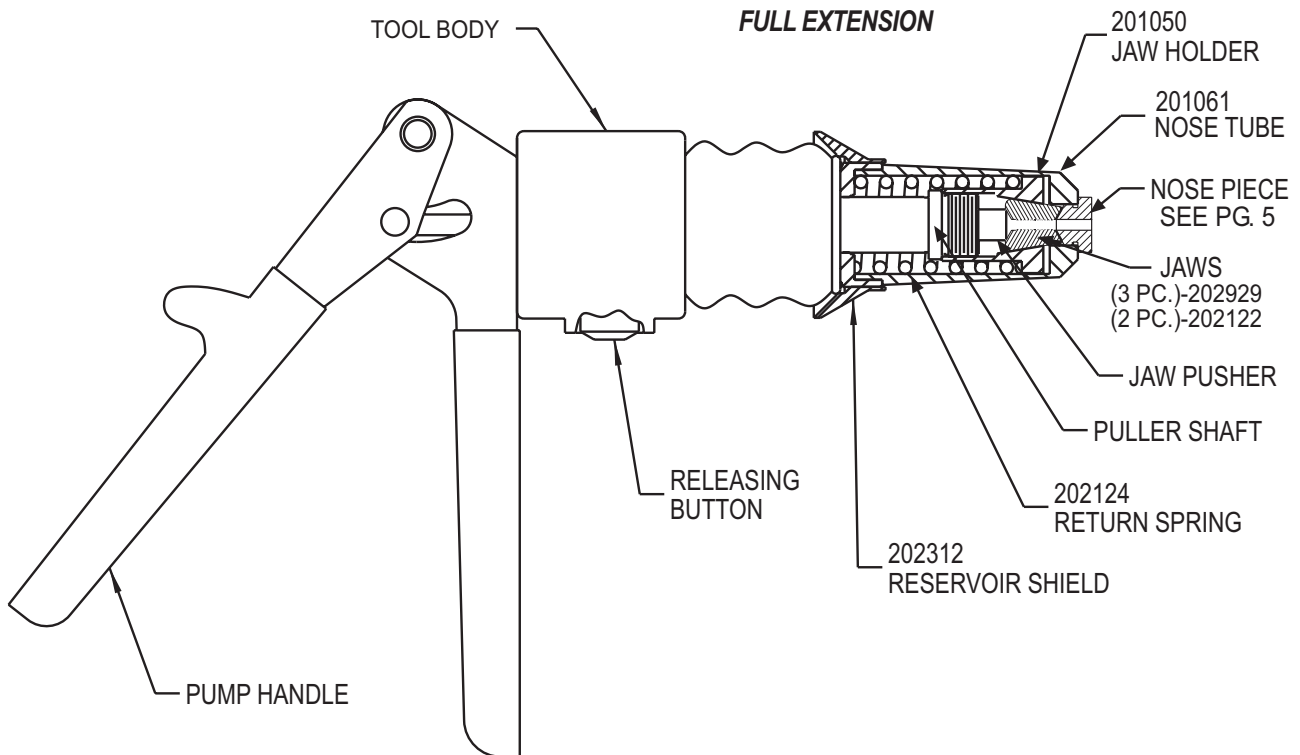

Figure 1



OPERATING INSTRUCTIONS



WARNINGS:

- Read full manual before using tool.
- A half-hour training session with qualified personnel is recommended before using Huck equipment.
- To avoid severe personal injury: Wear approved eye and ear protection.
- Be sure of adequate clearance for Operator's hands before proceeding with fastener installation.
- Tool shall not be operated if directed toward the operator or any person.
- Beware of ejection of fastener; turn head in each operation to avoid exposure.

READ INSTRUCTIONS THOROUGHLY PRIOR TO OPERATING THE RIVETER. THIS RIVETER IS DESIGNED FOR INTERMITTENT DUTY AND MAINTENANCE WORK ONLY.

The HK-150 hydraulic riveter installs fasteners by a pull and release system. Placing lever in "PULL" position, and pumping the handles (see figure 2 on the next page) will actuate the tool. After installing the fastener, the tool must be returned to its original position, which releases the pintail. To do this, point the tool downward, place lever in "RELEASE" position, and squeeze handles (see figure 3). The pintail should drop out.

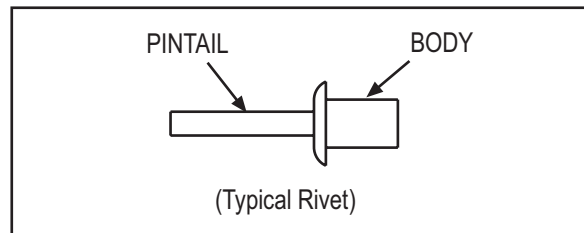

Nose Piece Installation:

1. Select the proper Nose Piece for the correct installation of fastener and function of tool.
2. Remove the Nose Piece in the tool by unscrewing it in a counterclockwise direction.
3. Hand tighten the Nose Piece into the Nose Tube.

Fastener Installation:

Install correct nose piece on tool (see Nose Piece installation section).

1. Insert pintail of rivet in to the Nose Piece.
2. Position the Rivet Body in to Work Piece to be fastened.
3. Hold the tool steady against the work piece and pump Handles until rivet is set and pintail is broken*. See figure 2



CAUTIONS:

- Before operating tool, make sure that all Nose parts have been screwed in **HAND TIGHT**.
- Frequently check that nose components do not vibrate loose during operation.

*The HK-150 has a .625 inch work travel and will set most rivets in one cycle. If the tool reaches the end of its travel before the rivet breaks, DO NOT continue pumping the handles on the tool. Release the tool by pressing RELEASE Button and then squeezing the handles. Next, regrip the rivet, and pump the HANDLES and finish the installation.

OPERATING INSTRUCTIONS *(continued)*

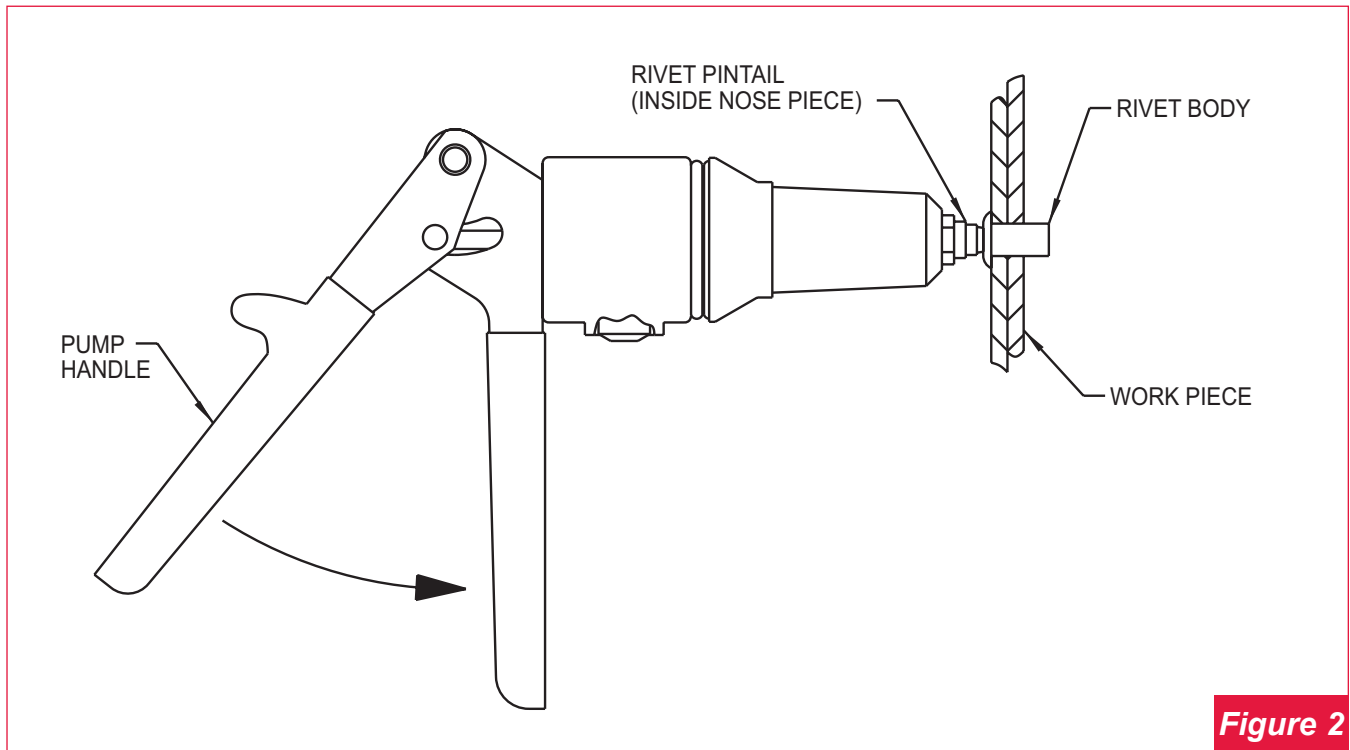

Figure 2

RIVET PINTAIL REMOVAL

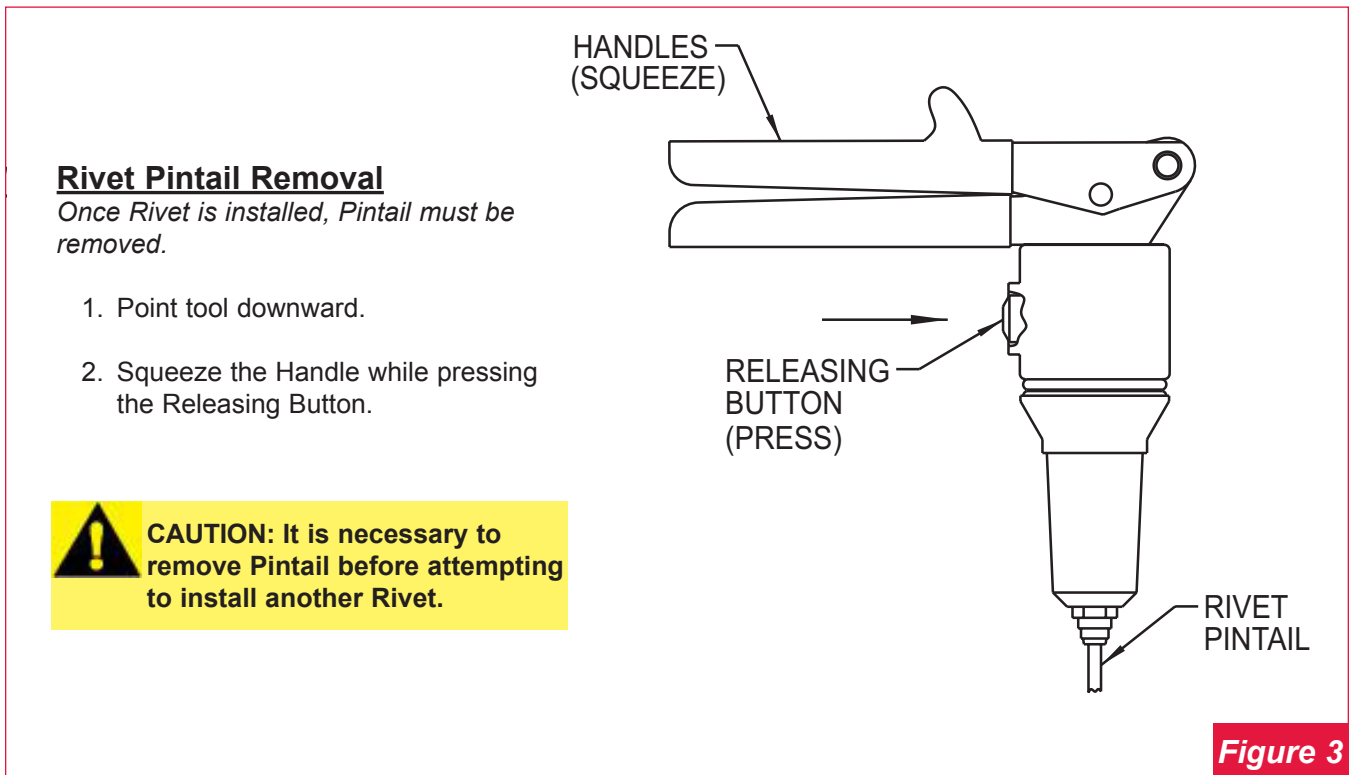
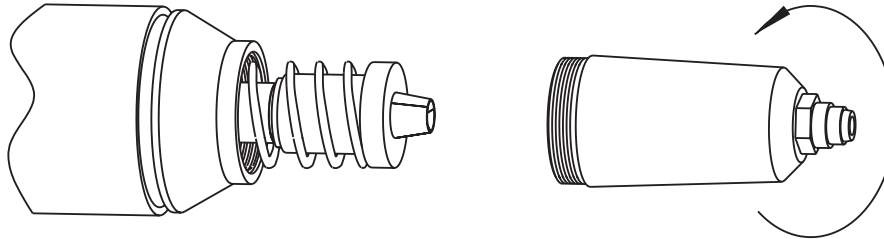

Figure 3



JAW INSTALLATION AND REMOVAL:

- 1** The jaws are installed at the factory and should only need to be removed for periodic inspection and cleaning. To remove the jaws unscrew the NOSE TUBE from the tool in a counterclockwise direction



2. TWO PIECE JAW SYSTEM

Remove the JAW HOLDER by unscrewing it in a counterclockwise direction. Drop JAWS out from SPRING side. Push JAW PUSHER flush with PULLER SHAFT while squeezing the RELEASING TRIGGER (See Figure 3 above).

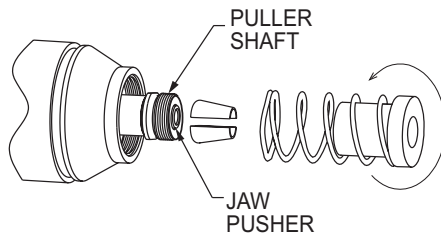

2. THREE PIECE JAW SYSTEM

Remove the JAW HOLDER by unscrewing it in a counterclockwise direction. Drop JAWS out from SPRING side. Actuate tool by squeezing the ACTUATING TRIGGER (see fig 3 above) until the jaw pusher is fully extended. Stop as soon as the JAW PUSHER is in the extended position.

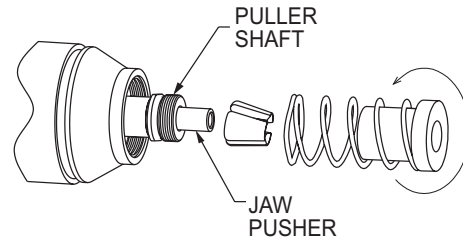

3. TWO PIECE JAW SYSTEM

To replace JAWS, hold JAW HOLDER large end down and at a slight angle. Place jaws in one at a time. Add a small amount of jaw lubricant to jaws and jaw holder prior to assembly.

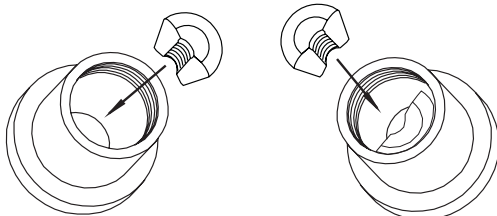

3. THREE PIECE JAW SYSTEM

To replace JAWS, hold JAW HOLDER large end down and at a slight angle. Hold finger over small opening and place jaws in one at a time. Add a small amount of jaw lubricant to jaws and jaw holder prior to assembly.

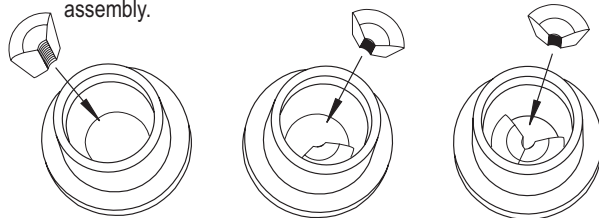

JAW INSTALLATION AND REMOVAL

(continued):

- 4.** When jaws are in place, insert jaw holder into spring, being sure to keep large end of jaw holder pointing downward.

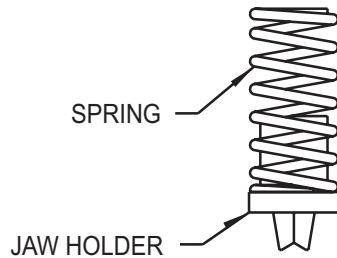

5. TWO JAW SYSTEM

Hold tool with the PULLER SHAFT pointing down and screw the jaw holder on to the PULLER SHAFT. HAND TIGHTEN ONLY.

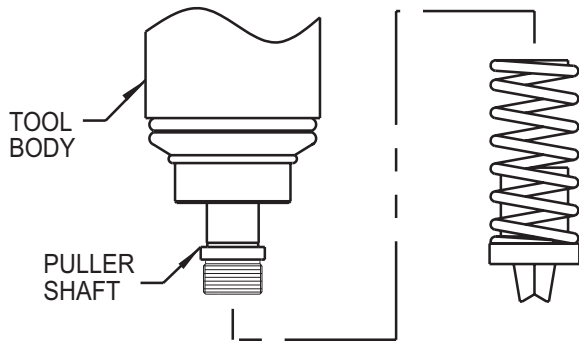

5. THREE JAW SYSTEM

Hold tool with the PULLER SHAFT pointing down and the JAW PUSHER fully extended. Screw the jaw holder on to the PULLER SHAFT. HAND TIGHTEN ONLY.

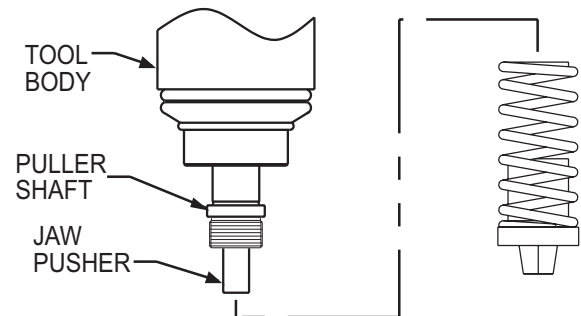

- 6.** Replace the NOSE TUBE and NOSE PIECE, HAND TIGHTEN ONLY. The tool is now ready to use.

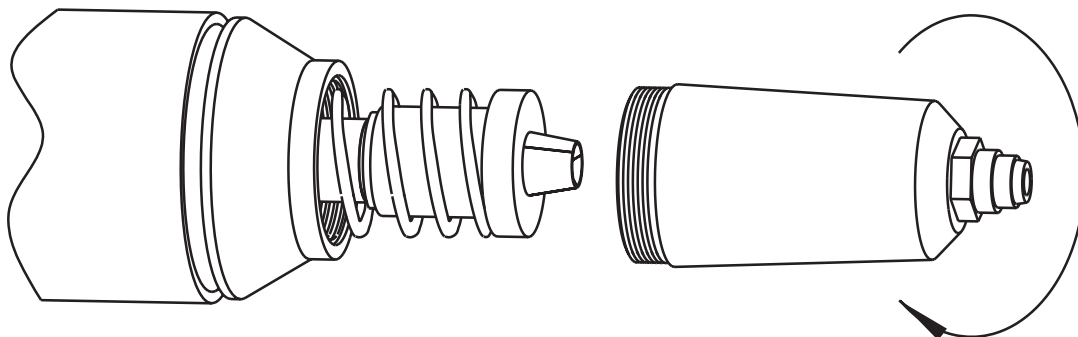



TOOL MAINTENANCE

Steps for Proper Tool Maintenance and Operation

1. Disassemble and clean Nose components periodically or if the pintails do not drop out freely. Use a pick to clean the jaw grooves. Wash components in mineral spirits or isopropyl alcohol. Apply a small amount of lubricant to the Jaws and inside of Jaw Holder prior to assembly.
2. To ease Nose Tube and Nose Piece installation, extend tool by pumping Handles.
3. **Do not use tool as a lever** if rivet pintail is jammed while regripping. Instead, squeeze Handles and press the Releasing Button while pushing tool nose against work piece for the jaws to get a deeper grip.
4. If rivet pintail is stuck in tool after breaking, lightly tap nose against a hard surface while squeezing Handles and pressing the Releasing Button with tool pointing downward. Pintail should then fall out.
5. Before operating tool, make sure that all Nose Parts have been screwed in hand tight.
6. The tool has a 5/8" work travel, the completion of which is indicated by a solid stop after approximately 12 pumps (one cycle). **Do not force beyond this point** to insure long life of tool.
7. The HK-150 should not be used at temperatures below 35°F unless it is first brought to room temperature and cycled several times. Normal use of the tool after warming should keep it warm enough for proper operation.
8. If tool will not reverse, remove Nose Tube and inspect for any foreign matter that might have caused jamming between Jaw Holder and inside of Nose Tube.
9. Frequently check that nose components do not vibrate loose during operation.
10. **Do not rock tool** when pumping it. This may cause rivets to prematurely break.
11. Large fasteners can be set one handed in tight areas by using short pump strokes.

Nose Pieces

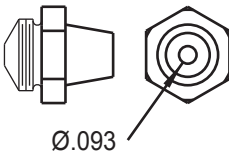
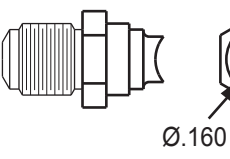
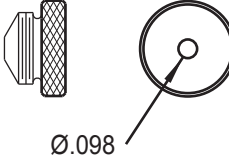
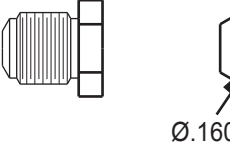
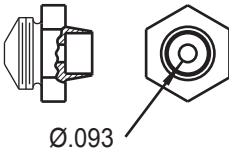
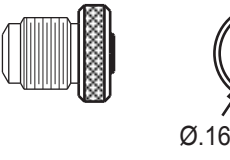
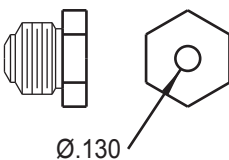
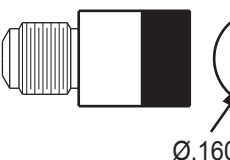
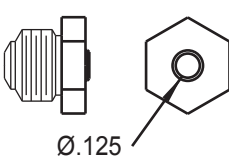
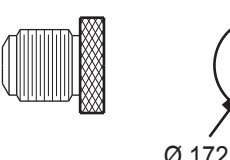
Part No.	Description	Part No.	Description
 202156	1/8" for Trim Molding Pop Rivets Ø.093	 202155	1/4" Auto Split "T" Rivets Ø.160
 202159	3/32" & 1/8" Pop Rivets Ø.098	 202157	Discontinued - Replaced by tip 202142 (pictured below) 1/4" Pop & Plastic Rivets Ø.160
 202190	1/8" Stand Off Pop Rivets Ø.093	 202169	1/4" Monobolts Ø.160
 202158	5/32" & 3/16" Pop & Plastic Rivets Ø.130	 202193	Spec. GM Glass Stop Travel, Pop Rivets Ø.160
 202168	3/16" Monobolts Ø.125	 202142	1/4" Magna Lok 1/4" Pop Rivets 1/4" Plastic Rivets Replaces Tip 202157 Ø.172



TROUBLESHOOTING

Problem	Solution
1.) Rivet pintail is stuck in tool	<p>First Step: Lightly tap nose against a hard surface while after breaking squeezing HANDLES and pressing down the RELEASING BUTTON with tool pointing downward Pintail should then fall out, see fig. 4. <i>If that does not work try Second Step.</i></p> <p>Second Step: <i>(Use this <u>only</u> if first step does not work)</i> Remove NOSE TUBE and JAW HOLDER (for help see figure 5) take out pintail and reassemble.</p>
2.) Tool will not reverse	Push on the handles until you feel a slight give, then press the RELEASING BUTTON and continue pushing on the handles, the tool should then reverse. If this does not work Remove NOSE TUBE and inspect for any foreign matter that may have cause the jamming between JAW HOLDER and the inside of NOSE TUBE.
3.) Fastener does not pull rivet	The JAW HOLDER is loose. Remove the NOSE TUBE and tighten the JAW HOLDER by turning it counterclockwise (see (See Three Piece Jaw Installation and Removal)).
4.) The rivet does not fit into the tool	The rivet is to large, or the wrong NOSE PIECE is on the tool. To find the correct NOSE PIECE (see chart on page 11). If you do not have the needed NOSE PIECE, See next page for how to order the correct one.
5.) Premature breaking	See solution for problem 4. Also verify the grip of the fastener and make sure you are not rocking the tool during installation.
6.) Jamming of tool	See solution for problem 4. Also verify that you have the proper jaw engagement and that all parts are hand tight and that the jaws are cleaned and properly assembled in jaw pusher (See Three Piece Jaw Installation and Removal)
7.) Rivet not installed properly	See solution for problem 4. Also verify jaw grip and that the appropriate fastener is being used.
8.) Jaws breaking	See solution for problem 4. Check to see all parts are properly assembled and hand tight.
9.) Damaged jaw pusher	See solution for problem 4. Check to see if all parts are properly assembled.



OPTIONAL ACCESSORIES

NOSE PIECES

202156	1/8" for Trim Molding Pop Rivets
202159	3/32" & 1/8" Pop Rivets
202190	1/8" Stand Off Pop Rivets
202158	5/32" & 3/16" Pop and Plastic Rivets
202168	3/16" Monobolts
202155	1/4" Auto Split "T" Rivets
202157	Discontinued. Use tip 202142.
202169	1/4" Monobolts
202193	Spec. GM Glass Stop Travel, Pop Rivets
202142	1/4" Magna Lok 1/4" Pop Rivets 1/4" Plastic Rivets Replaces tip 202157

JAWS

202122	Two Piece Jaws
202929	Three Piece Jaws

KITS

205490	Nose Extension Kit
205400	Nut Setter Kit
205401	Metric Nut Setter Kit
205403	Rivnut Nut Setter Kit
126016	Rivet Stem Removal Tool "Punch Assy"

Service Notes:



CONVERTING A RIVETER TO A NUTSETTER

The HK-150 can be converted from a riveter to a nutsetter by changing several of the nose components. No tools required as parts require hand tightening only.

RIVETER

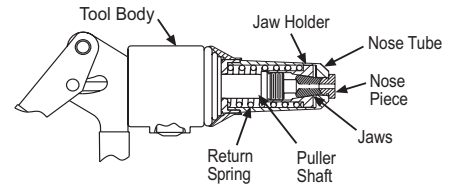

NUTSETTER

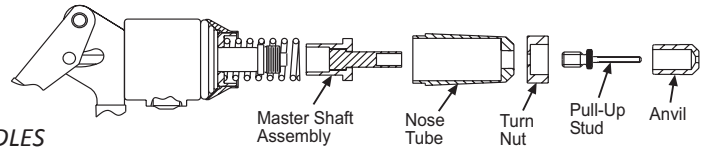

1. Completely retract the tool by squeezing HANDLES and pressing the RELEASING BUTTON. (Figure 3)

2. Remove NOSE PIECE from NOSE TUBE. Remove NOSE TUBE, JAWS and JAW HOLDER.

The parts that were removed should be stored for future use as a riveter. The tool is ready to start adding NUTSETTER accessories as follows:

3. Screw MASTER SHAFT assembly on PULLER SHAFT and replace NOSE TUBE as shown.

4. Slide TURN NUT over the extended section of the MASTER PULLER SHAFT. Screw the appropriate PULL-UP STUD into MASTER SHAFT ASSEMBLY. (NOTE: this is a left hand thread and must be screwed in counterclockwise.)

5. Push appropriate ANVIL over PULL-UP STUD into TURN-NUT.

The HK-150 NUTSETTER sets 3mm through 3/8-24 threaded aluminum inserts and up to 1/4-20 steel inserts. Size changes are accomplished by changing the PULL-UP STUD and ANVIL. No tools required.

Installing threaded Inserts:

1. Make sure proper Pull-up Stud and are Anvil in place.
2. Thread the insert on the Pull-up Stud until all threads on the insert are engaged.
3. Position the Insert into workpiece with the appropriate size hole and pump the Handles until the Insert is set.

(You will feel the tool come to a definite stop when the insert is properly set. STOP PUMPING HANDLES)

Releasing the Tool: (After Insert has been set in the workpiece)

1. Press the Releasing Button while squeezing Handles.
2. Rotate the Turn Nut in a counterclockwise direction until the Pull-up Stud is released from the Threaded Insert.

HK-150 Nutsetter

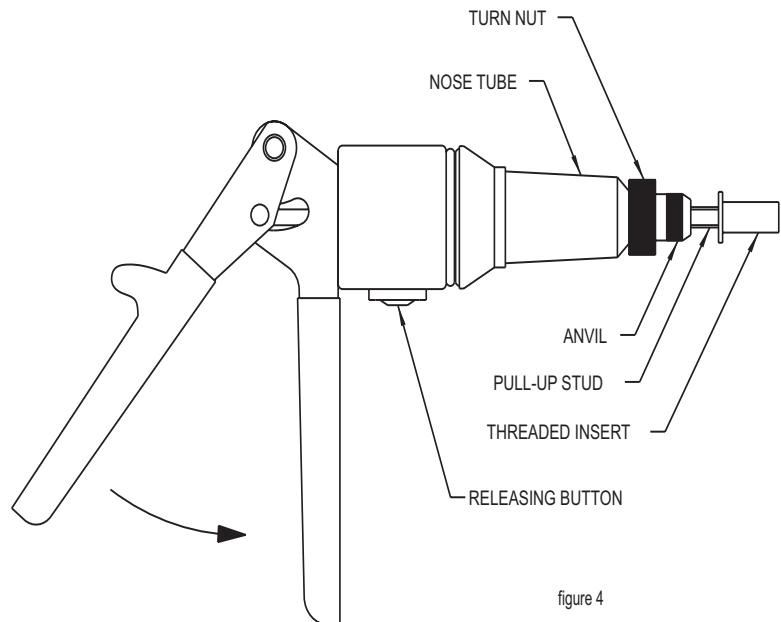

figure 4



90 DAY WARRANTY ON HK-150 RIVETER

All Arconic Fastening Systems tools and parts have been carefully tested and checked at the factory and are guaranteed to be free from defects in material and workmanship, subject to the following conditions.

- A.) The tools manufactured by Arconic Fastening Systems will be repaired free of charge or replaced at our discretion within 90 days of sale to the first user if, upon examination at our service center, we find a defect in material or workmanship in the hydraulic system.
- B.) The tool must be returned intact and prepaid to one of our service centers. Proof of date of sale must accompany any tool returned. This warranty will be void if repairs have been made or attempted by others, or if the tool has been subject to abuse, neglect, accident or improper application.
- C.) The foregoing obligation is Arconic Fastening Systems' sole liability under this or any implied warranty, and no one is authorized to vary its terms or conditions.
- D.) If you have any problems please contact Customer Service at the factory: 209-839-3000.

Before returning tools to the service center, please use the operation and maintenance tips on page 9 of this manual. If the tool continues to malfunction call the Customer Technical Support at Arconic Fastening Systems and Rings 209-839-3000 for additional assistance.

AUTHORIZED TOOL SERVICE CENTER:

Bay Fastening Systems

30 Banfi Plaza North
Farmingdale, NY 11735
516 294 4100
516 294 3447 (Fax)

Universal Repair Shop

1611 Boylston Avenue
Seattle, WA 98122
206 322 2726
206 322 2126 (Fax)

Mountainair Rivet Tools

115 West Broadway
Mountainair, NM 87036
479 936 7577
505 847 2207
505 847 2465 (Fax)

Professional Tool Center

2236 S.116th Street
West Allis, WI 53227
414 321 1234
414 321 2524 (Fax)

FSI

1206 East Mac Arthur St
Sonoma, CA 95476
707 935 1170
800 344 2394 (Toll Free)
707 935 1828 (Fax)



LIMITED WARRANTIES

Tooling Warranty: Huck warrants that tooling and other items (excluding fasteners, and hereinafter referred as “other items”) manufactured by Huck shall be free from defects in workmanship and materials for a period of ninety (90) days from the date of original purchase.

Warranty on “non standard or custom manufactured products”: With regard to non-standard products or custom manufactured products to customer’s specifications, Huck warrants for a period of ninety (90) days from the date of purchase that such products shall meet Buyer’s specifications, be free of defects in workmanship and materials. Such warranty shall not be effective with respect to non-standard or custom products manufactured using buyer-supplied molds, material, tooling and fixtures that are not in good condition or repair and suitable for their intended purpose.

THERE ARE NO WARRANTIES WHICH EXTEND BEYOND THE DESCRIPTION ON THE FACE HEREOF. HUCK MAKES NO OTHER WARRANTIES AND EXPRESSLY DISCLAIMS ANY OTHER WARRANTIES, INCLUDING IMPLIED WARRANTIES AS TO MERCHANTABILITY OR AS TO THE FITNESS OF THE TOOLING, OTHER ITEMS, NONSTANDARD OR CUSTOM MANUFACTURED PRODUCTS FOR ANY PARTICULAR PURPOSE AND HUCK SHALL NOT BE LIABLE FOR ANY LOSS OR DAMAGE, DIRECTLY OR INDIRECTLY, ARISING FROM THE USE OF SUCH TOOLING, OTHER ITEMS, NONSTANDARD OR CUSTOM MANUFACTURED PRODUCTS OR BREACH OF WARRANTY OR FOR ANY CLAIM FOR INCIDENTAL OR CONSEQUENTIAL DAMAGES.

Huck’s sole liability and Buyer’s exclusive remedy for any breach of warranty shall be limited, at Huck’s option, to replacement or repair, at FOB Huck’s plant, of Huck manufactured tooling, other items, nonstandard or custom products found to be defective in specifications, workmanship and materials not otherwise the direct or indirect cause of Buyer supplied molds, material, tooling or fixtures. Buyer shall give Huck written notice of claims for defects within the ninety (90) day warranty period for tooling, other items, nonstandard or custom products described above and Huck shall inspect products for which such claim is made.

Tooling, Part(s) and Other Items not manufactured by Huck.

HUCK MAKES NO WARRANTY WITH RESPECT TO THE TOOLING, PART(S) OR OTHER ITEMS MANUFACTURED BY THIRD PARTIES. HUCK EXPRESSLY DISCLAIMS ANY WARRANTY

EXPRESSED OR IMPLIED, AS TO THE CONDITION, DESIGN, OPERATION, MERCHANTABILITY OR FITNESS FOR USE OF ANY TOOL, PART(S), OR OTHER ITEMS THEREOF NOT MANUFACTURED BY HUCK. HUCK SHALL NOT BE LIABLE FOR ANY LOSS OR DAMAGE, DIRECTLY OR INDIRECTLY, ARISING FROM THE USE OF SUCH TOOLING, PART(S) OR OTHER ITEMS OR BREACH OF WARRANTY OR FOR ANY CLAIM FOR INCIDENTAL OR CONSEQUENTIAL DAMAGES.

The only warranties made with respect to such tool, part(s) or other items thereof are those made by the manufacturer thereof and Huck agrees to cooperate with Buyer in enforcing such warranties when such action is necessary.

Huck shall not be liable for any loss or damage resulting from delays or nonfulfillment of orders owing to strikes, fires, accidents, transportation companies or for any reason or reasons beyond the control of the Huck or its suppliers.

Huck Installation Equipment

Huck International, Inc. reserves the right to make changes in specifications and design and to discontinue models without notice.

Huck Installation Equipment should be serviced by trained service technicians only.

Always give the Serial Number of the equipment when corresponding or ordering service parts.

Complete repair facilities are maintained by Huck International, Inc.

Authorized Tool Service Centers (ATSC's) offer repair services, spare parts and nose inserts and accessories.



Howmet Fastening Systems Tooling Support Locations

North America

Waco Operations

PO Box 8117
8001 Imperial Drive
Waco, TX 76714-8117
Tel: +1 800-388-4825
Fax: +1 800-798-4825
sales.waco@howmet.com

Tracy Operations

1925 North MacArthur Drive
Tracy, CA 95376
Tel: +1 800-826-2884
Fax: +1 800-573-2645
sales.idg@howmet.com

Kingston Operations

1 Corporate Drive
Kingston, NY 12401
Tel: +1 800-278-4825
Fax: +1 845-334-7333
sales.kingston@howmet.com

Global

Telford Operations

Unit C, Stafford Park 7
Telford, Shropshire
England TF3 3BQ
Tel: +44 (0) 1952-290011
Fax: +44 (0) 1952-290459
sales.telford@howmet.com

Melbourne Operations

1508 Centre Road
Clayton, Victoria
Australia 3168
Tel: +613-8545-3333
Fax: +613-8545-3390
hfsmel.sales@howmet.com

Tokyo Operations (Japan & Korea)

8F CIRCLES Nihonbashi-
Bakurocho Bldg
1-5-12 Nihonbashi-Bakurocho
103-0002 Tokyo Japan
Tel: +81-3-5642-8360
Tel: +81-3-5642-8361 x8365
Fax: +81-3-5644-5772

Suzhou Operations

58 Yinsheng Road,
SIP Suzhou, Jiangsu
215126 China
Tel: +86-512-62863800-8888

Aerospace North America

Simi Valley Operations

3990A Heritage Oak Court
Simi Valley, CA 93063
Tel: +1-805-527-3600
Fax: +1-805-527-0900
www.afs-simivalley.com

Kingston Operations

1 Corporate Drive
Kingston, NY 12401
Tel: +1 800-278-4825
Fax: +1 845-334-7333
hfs.sales.kingston@howmet.com

Aerospace Global

Aichach Operations

Robert-Bosch Str. 4
Aichach 86551, Germany
Tel: +49-8251-8757-0
aicafswelcomedl@arconic.com

Cergy Operations

15 Rue du Petit Albi
F-95611 Cergy Pontoise, France
Tel: +33-1-34-33-98-00
Fax: +33-1-34-33-97-77

Hong Kong Operations

27th Floor, 88 Hing Fat Street
Causeway Bay
Hong Kong, China
Tel: +852-2864-2012

hfsindustrial.com/tooling

The information contained in this publication is only for general guidance, and is not intended to create any warranty, express, implied, or statutory; all warranties are contained only in Howmet Fastening Systems' written quotations, acknowledgments, and/or purchase orders. It is recommended that the user secure specific, up-to-date data and information regarding each application and/or use of such products.

ISO 9001-2015

INTERNATIONAL
ORGANIZATION FOR
STANDARDIZATION

ISO 14001-2015

Howmet Fastening Systems Kingston Operations

1 Corporate Drive, Kingston, NY 12401
Tel: 800-431-3091 | Fax: 845-334-7333

Huck is a trademark of Howmet Aerospace Inc. and/or its subsidiaries. ©
2020 Huck International, Inc. 0520