



SERVICE PARTS LIST

BULLETIN NO.
54-26-2785

SPECIFY CATALOG NO. AND SERIAL NO. WHEN ORDERING PARTS		REVISED BULLETIN	DATE
M18™ FUEL™ 3/8" Square Impact Wrench (Wireless)			Oct. 2015
CATALOG NO.	2758-20	STARTING SERIAL	G81A
			WIRING INSTRUCTION SEE PAGE 2

EXAMPLE:
00 0 Component Parts (Small #) Are Included
When Ordering The Assembly (Large #).

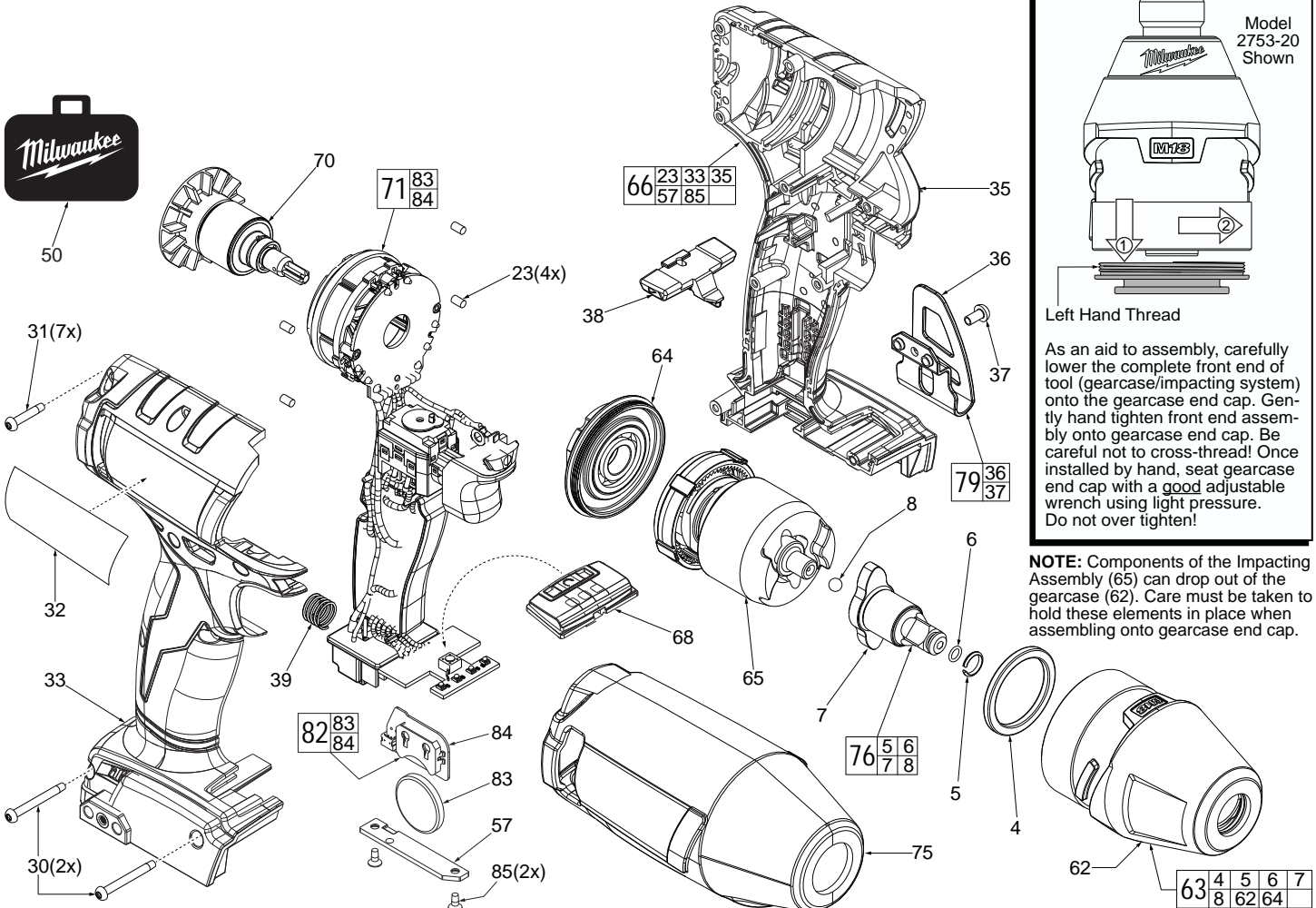

IMPORTANT NOTE: Gearcase end cap #64 is LEFT HAND THREAD!

Model 2753-20 Shown

Left Hand Thread

As an aid to assembly, carefully lower the complete front end of tool (gearcase/impacting system) onto the gearcase end cap. Gently hand tighten front end assembly onto gearcase end cap. Be careful not to cross-thread! Once installed by hand, seat gearcase end cap with a good adjustable wrench using light pressure. Do not over tighten!

NOTE: Components of the Impacting Assembly (65) can drop out of the gearcase (62). Care must be taken to hold these elements in place when assembling onto gearcase end cap.

FIG.	PART NO.	DESCRIPTION OF PART	NO. REQ.
4	45-88-2653	Plastic Washer	(1)
5	44-90-1050	Friction Ring	(1)
6	34-40-1885	O-Ring	(1)
7	-----	3/8" Square Anvil	(1)
8	02-02-1300	5.0mm Steel Ball	(1)
23	45-30-2653	Rubber Slug	(4)
30	06-82-0013	M3 x 38mm Pan Hd. ST TP T-10 Screw	(2)
31	06-82-7326	M3 x 16mm Pan Hd. ST TP T-10 Screw	(7)
32	12-20-0046	Service Nameplate	(1)
33	-----	Housing Halve - Right	(1)
35	-----	Housing Halve - Left	(1)
36	-----	Belt Clip	(1)
37	06-82-0130	6-32 x 5/16" Pan Hd. T-15 Screw	(1)
38	45-24-0013	Forward / Reverse Shuttle	(1)
39	40-50-1090	Spring	(1)
50	42-55-0024	Blow Molded Carrying Case	(1)
57	42-92-2757	Coin Cell Cover	(1)
62	28-50-0014	Gearcase with Bushing	(1)
63	14-30-0014	Gearcase / Anvil Assembly	(1)
64	44-66-0028	Gearcase End Cap with Ball Bearing	(1)
65	14-46-0016	Impacting Assembly	(1)
66	31-44-0048	Housing Assembly	(1)
68	45-24-0061	Speed Selector Assembly	(1)
70	16-07-2754	Rotor Assembly	(1)

FIG.	PART NO.	DESCRIPTION OF PART	NO. REQ.
71	14-20-0017	Electronics Assembly Consisting of: On-Off Switch, PCBA, Stator, LED, HV Protection, Battery Connector Block, Coin Cell PCBA and Coin Cell	(1)
75	49-12-0012	Rubber Boot (Optional, Accessory)	(1)
76	42-06-0013	3/8" Square Anvil Assembly	(1)
79	72-70-0059	Belt Clip Assembly	(1)
82	22-09-2757	Coin Cell PCBA with Battery	(1)
83	50-11-0020	3V Coin Cell Battery (CR 2032)	(1)
84	-----	Coin Cell PCBA	(1)
85	05-81-1100	M2.6 x 6mm Phillips Screw	(2)

FIG. LUBRICATION
(Type 'J' Grease, No. 49-08-4220):

62 Coat inside of bushing inside front gearcase (62) with grease.

65 Lightly coat the I.D. of the ring gear and the center of the planet gears of impacting assembly (65) with grease.

70 Coat pinion of rotor assembly (70) with grease.

Rotor Assembly

Stator Assembly with Hall PCBA

Watch for pinched wires here. Tuck leads down in cavity behind switch.

Main PCBA

Battery Connector Block Assembly

Compression Spring

High Voltage Protection Wire. Place terminal over screw boss and route down in cavity behind forward/reverse shuttle.

Route LED wires down in cavity behind forward/reverse shuttle.

LED Assembly

On-Off Switch

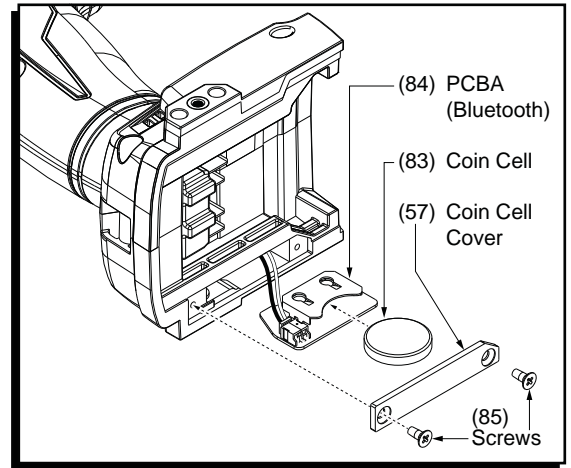

Speed Selector Assembly

Speed PCBA