

**Side-by-Side Adaptor(not include):** When setting studs closer than 1" apart (required if using Uni-Clamp puller (UNI-1080), the side-by-side adaptor must be installed.

**The earth ring spacer collar (UNI-1041)** allows space to go "over" installed stud and the **electrode extension (UNI-1044)** allows the tip to make contact. Install collar over earth ring with twisting motion and insert extension for stud tip. Be sure both extension and tip holder are securely locked-in the electrode.

**Set Wiggle Wire:** (NOTE: Wire components are not included in the kit but are available from your dealer) Setting wire will require the earth ring spacer collar and the **chisel wire tip**. The earth extension collar is installed as above and the chisel wire tip is inserted into the electrode. Be sure to stand the wire with loops pointed up for easy attachment to pulling claws (**Safety gloves must be worn**). While holding wire in position, place chisel tip in valley between wire bends and push gun towards panel insuring full contact with spacer collar legs. Pull trigger for ½ second and repeat for each valley along the crease. Both wire tip and collar extension are available in **UNI-2120 Uni-Wire Deluxe Kit** and **UNI-2130 Uni-Wire conversion Kit** sold separately.

#### 4. REPLACEMENT PARTS LIST:

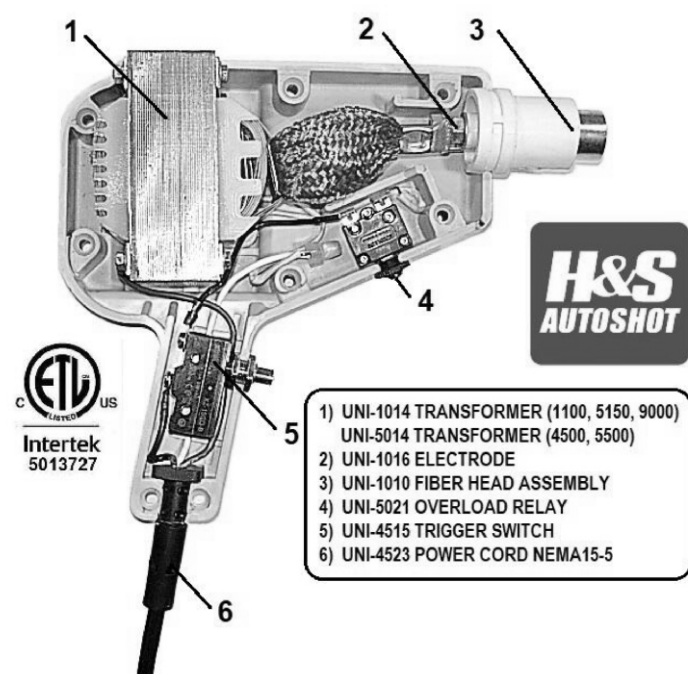

- 1) UNI-1014 TRANSFORMER (1100, 5150, 9000)  
UNI-5014 TRANSFORMER (4500, 5500)
- 2) UNI-1016 ELECTRODE
- 3) UNI-1010 FIBER HEAD ASSEMBLY
- 4) UNI-5021 OVERLOAD RELAY
- 5) UNI-4515 TRIGGER SWITCH
- 6) UNI-4523 POWER CORD NEMA15-5

#### WARRANTY:

Subject to the terms & conditions following, H&S Autoshot warrants to the original purchaser that the equipment is free of defects in material or workmanship at time of shipment from H&S Autoshot. Within the periods below,

H&S Autoshot will repair or replace components that fail due to such. Warranty time period starts on the date of purchase by the end-user. This limited warranty does not cover wear and tear or damage due to neglect or misuse. Item must be returned to factory.

Three-Year Parts & Labor: Transformer & housing material workmanship.  
One-Year Parts & Labor: All internal electrical components and power cord.  
To initiate a claim, please contact the manufacturer at the following:

**H&S Autoshot / 302 Rolling Hill Rd. / Mooresville, NC / 980-500-1015**



## UNI-SPOTTER® Stud Welding System

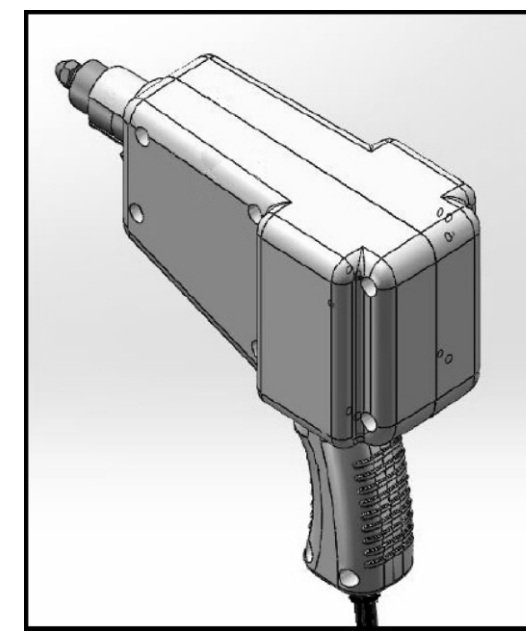

### Operator Manual

**IMPORTANT: Read this Owner's Manual Completely** before attempting to use this equipment. Save this manual and keep it handy for quick reference. Pay particular attention to the safety instructions we have provided for your protection. Contact your distributor if you do not fully understand this manual.

## IMPORTANT SAFETY INSTRUCTIONS



OPERATION AND MAINTENANCE OF SPOT WELDING EQUIPMENT CAN BE DANGEROUS AND HAZARDOUS TO YOUR HEALTH. OBSERVE ALL WARNINGS AND INSTRUCTIONS.

- Only qualified persons should install, operate, maintain and repair this unit.
- Unit is to be used by professional in a safe and controlled work environment.
- Repair or replace all worn or damaged parts with factory authorized components
- Keep all panels, covers, and guards in place at all times.



ELECTRIC SHOCK CAN KILL. TOUCHING LIVE ELECTRICAL PARTS (I.E.: ELECTRODE) CAN CAUSE FATAL SHOCKS. DISCONNECT POWER TO UNIT BEFORE SERVICE OR REPAIR.

- Never modify 3-prong power cord, **extension cords are not recommended**.
- Unit must be grounded by power cord connection to NEMA5-15R outlet.
- Never touch any parts that are electrically "live" or "hot."
- Wear dry gloves and clothing. Insulate yourself from the work piece and live torch parts.
- Extra care must be taken when the workplace is moist or damp.



FIRE AND EXPLOSION HAZARD. FIRE AND EXPLOSIONS CAN BE IGNITED BY HOT SPARKS GENERATED BETWEEN STUD AND SURFACE. PERFORM WORK IN SAFE ENVIRONMENT.

- Be sure there is no combustible or flammable material in the workplace.
- Ventilate all flammable or explosive vapors from the workplace.
- Do not weld on containers that may have held combustibles.
- Do not weld on panels containing insulation materials that may be ignited by heat.
- Provide a fire watch when working in an area where fire hazards may exist.



PROTECTIVE CLOTHING AND EYEWEAR MUST BE WORN AT ALL TIMES!

- Wear approved UV/IR safety glasses with side shields other protective eye wear.
- Wear protective clothing made from durable flame-resistant material & foot protection.

Thank you for choosing the **UNI-SPOTTER™** stud welder, the #1 selling stud welder in North America. This professional stud welding system will provide years of superior service provided that it is used correctly and maintained over its lifetime.

This product is designed specifically to repair automotive, truck & motorcycle steel panels and covers utilizing **UNI-Stud pins, UNI-Tab rings, molding rivets or UNI-Wire pulling wire.**

Please read this instruction manual carefully before using and keep with unit for reference.

#### CONTENTS

- 1. SPECIFICATIONS
- 2. COMPONENT LIST
- 3. GENERAL OPERATION
- 4. REPLACEMENT PARTS LIST

#### 1. SPECIFICATIONS:

Product Name: **UNI-SPOTTER™** Resistance Stud Welder  
Model No's.: UNI-4550, SS4575A, WS275A  
Electrical Input: 120VAC, Single-Phase 50/60Hz w/ 11eff: 12A & 11max: 25A  
Electrical Output: 2.5VAC @ 2500A peak (2% Duty-Cycle @ 104°F)  
Certification: Intertek **CSA STD. C22.2 No.107.0** Conforms to **UL STD. 1012**  
Manufacturer: H&S Autoshot, Mooresville, NC, 980-500-1015, [www.hsautoshot.com](http://www.hsautoshot.com)

#### 2. COMPONENT LIST:

- A) **UNI-SPOTTER™** Stud Welder
- B) UNI-1001 Uni-Stud 2.2mm (500-Pk)
- C) UNI-1004 Stud tip holder
- D) UNI-1016 Slide hammer

#### 3. GENERAL OPERATION:

**Work Area:** Be certain surface is clean, bare metal free of paint, primer oil & dust. Clean area should be 1" min. from all weld points and be brushed or sanded and cleaned minutes prior to welding.

**Plug-In Welder:** Insert 3-prong NEMA5-15 plug into standard 115VAC wall outlet. Use of extension cord is not recommended as any extension could result in loss of power; however, if required, cord should be AWG12-3 (Min.) and not exceed 25' TOTAL length (including cord).



**Select Tip:** Insert tip into electrode bore making sure of positive contact.

**Select Puller type:** Chose 2.2 or 2.6 Uni-stud.

Be certain to fully insert pin into tip. **DO NOT USE PANEL TO PUSH-IN!!**

**Earth Ring Contact:** Ring must be CLEAN of oxidation and make complete contact w/panel. After multiple uses, take care to clean earth ring with emery cloth or steel wool so contact surface is bright. Any spark indicated problem.

**Set Pin or Tab:** Align pin or tab tip to proper location on the panel. Push the gun forward making complete contact between the earth ring and panel. Any "gaps" will create sparks and decrease weld strength. **Pull trigger for ½ - 1 second only.** In resistance welding, SHORTER cycle time creates a STRONGER weld. If trigger is held for longer duration, excessive heat builds up in head assembly and additional pins will not adhere to panel. For maximum performance, tip must be COOL before setting studs or tabs.

#### ADDITIONAL ACCESSORIES AVAILABLE FROM YOR DEALER:



**T-Handle Puller (not include):** If you are using the UNI-1095 Mini T-Handle puller for individual stud pins. This tool is designed for both 2.2mm Flex and 2.6mm Heavy-flex stud pins. Simply insert pin extension into shaft while pushing roller away from handle. Once complete inserted, pull roller with thumb towards handle, engaging stud shaft. Pull stud as required. To remove, simply push roller away from handle while pushing handle towards panel. The same stud may be engaged multiple times before being removed upon completion.