



655 Eisenhower Drive
 Owatonna, MN 55060 USA
 Phone: (507) 455-7000
 Tech. Serv.: (800) 533-6127
 Fax: (800) 955-8329
 Order Entry: (800) 533-6127
 Fax: (800) 283-8665
 International Sales: (507) 455-7223
 Fax: (507) 455-7063

Form No. 555192

Parts List for: 6529-4

GM Ball Joint Adapter Kit

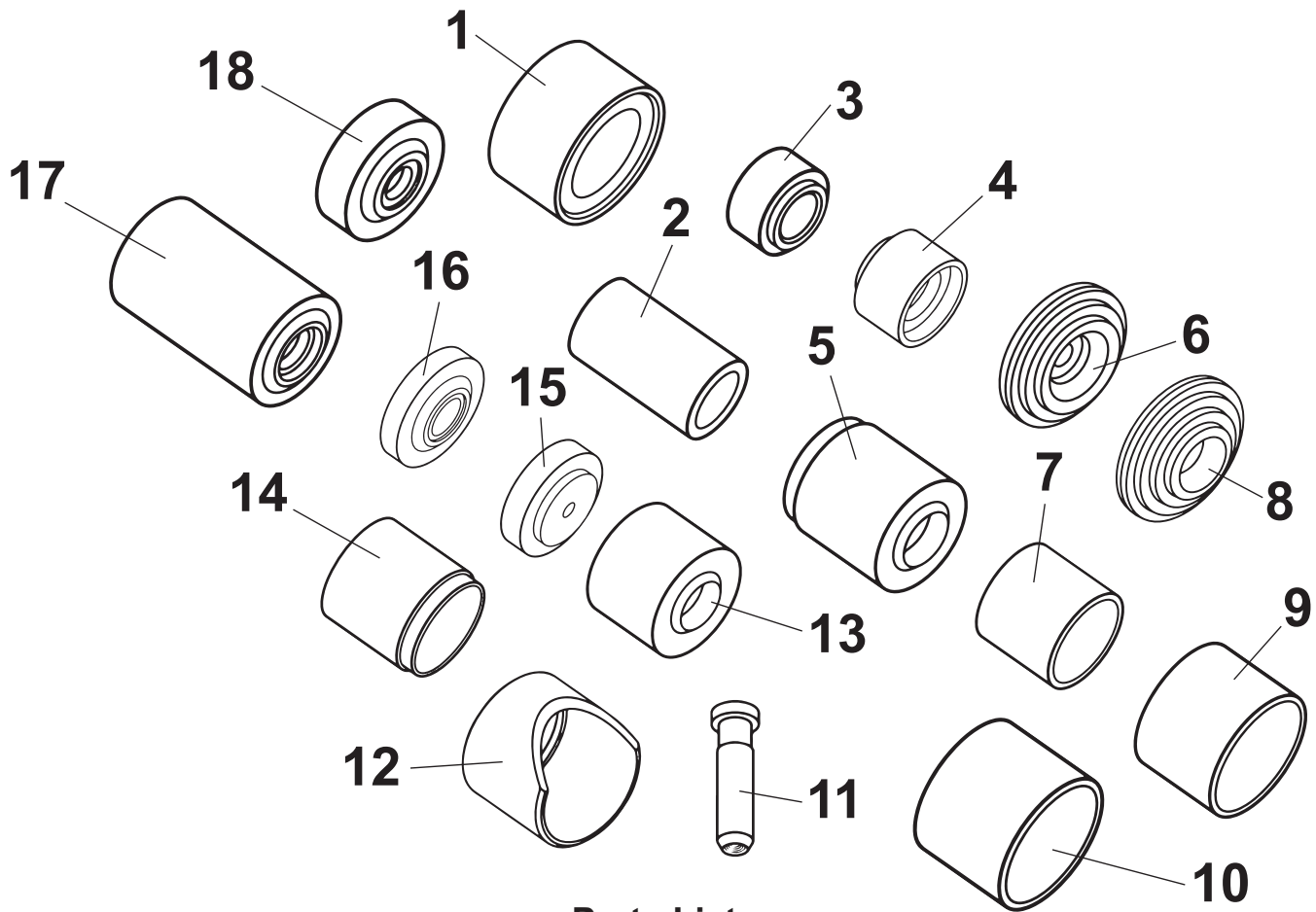

Parts List

Item No.	Part No.	Description	Item No.	Part No.	Description
1	554417	Adapter	11	314392	Plug
2	554399	Adapter	12	537499	Adapter
3	313968	Adapter	13	39976	Adapter
4	554415	Adapter	14	554413	Adapter
5	38354	Adapter	15	554403	Adapter
6	305228	Adapter	16	554414	Adapter
7	29505	Adapter	17	38355A	Adapter
8	305227	Adapter	18	204508A	Adapter
9	29504	Adapter			
10	29503	Adapter			

NOTE: Models not listed most likely require the control arm with ball joint assembly be replaced, or has a bolt-in style ball joint.

Buick

Model	Year	Type	Position	Location	Removal Adapters	Installation Adapters	Page
LeSabre	1986-1999	Car	Lower	Rear	38354, 554399	38355A, 554414	4
Park Avenue	1991-1997	Car	Lower	Rear	38354, 554399	38355A, 554414	4
Roadmaster	1991-1996	Car	Lower	Front	29503, 305228, 554415	305227, 537499, 554417	5

Cadillac

Model	Year	Type	Position	Location	Removal Adapters	Installation Adapters	Page
CTS	2003-2008	Car	Lower	Front	29504, 305228, 554414	29504, 204508A, 305227	6
DeVille w/ standard-duty suspension	1996-1999	Car	Lower	Front	29503, 29504, 305227, 305228	29504, 305228	7
DeVille w/ heavy-duty suspension	1997-2005	Car	Lower	Front	29503, 305228, 555376	29503, 305227, 554417	8
DTS	2006-2011	Car	Lower	Front	29503, 305228, 555376	29503, 305227, 554417	8
Fleetwood	1993-1996	Car	Lower	Front	29503, 305228, 554415	305227, 537499, 554417	5
XLR	2007-2009	Car	Lower	Front	29504, 305228, 554415	39976, 554417	9
XLR	2004-2009	Car	Upper	Front	313968, 554413	29505, 305227, 554403	10
XLR-V	2006-2009	Car	Lower	Front	29504, 305228, 554415	39976, 554417	9
XLR-V	2006-2009	Car	Upper	Front	313968, 554413	29505, 305227, 554403	10

Chevrolet

Model	Year	Type	Position	Location	Removal Adapters	Installation Adapters	Page
Camaro	1970-2002	Car	Lower	Front	29503, 305228, 554415	305227, 537499, 554417	5
Caprice	1977-1996	Car	Lower	Front	29503, 305228, 554415	305227, 537499, 554417	5
Corvette	1984-1996	Car	Lower	Front	29503, 29504, 305227, 305228	29504, 305227, 554414	11
Corvette	1997-2011	Car	Lower	Front	29504, 305228, 554415	39976, 554417	9
Corvette	1997-2011	Car	Upper	Front	313968, 554413	29505, 305227, 554403	10
Impala	1994-1996	Car	Lower	Front	29503, 305228, 554415	305227, 537499, 554417	5

Oldsmobile

Model	Year	Type	Position	Location	Removal Adapters	Installation Adapters	Page
88	1985-1999	Car	Lower	Rear	38354, 554399	38355A, 554414	4
98	1985-1996	Car	Lower	Rear	38354, 554399	38355A, 554414	4
LSS	1996-1999	Car	Lower	Rear	38354, 554399	38355A, 554414	4
Regency	1997-1998	Car	Lower	Rear	38354, 554399	38355A, 554414	4

Pontiac

Model	Year	Type	Position	Location	Removal Adapters	Installation Adapters	Page
Bonneville	1987-1999	Car	Lower	Rear	38354, 554399	38355A, 554414	4
Firebird	1970-2002	Car	Lower	Front	29503, 305228, 554415	305227, 537499, 554417	5
Solstice	2006-2007	Car	Lower	Front	29504, 305228, 554415	39976, 554417	9

Explanation of Safety Signal Words

 **WARNING:** Indicates a potentially hazardous situation which, if not avoided, could result in death or serious injury.

 **CAUTION:** Indicates a potentially hazardous situation which, if not avoided, may result in minor or moderate injury.

CAUTION: Used without the safety alert symbol indicates a potentially hazardous situation which, if not avoided, may result in property damage.

Notes: Provide clarity and helpful information.

Safety Precautions

 **CAUTION:** To prevent personal injury,



- Wear protective eyewear that meets the requirements of ANSI Z87.1 and OSHA.



- Before performing any repairs on a vehicle, block all wheels to prevent movement.

- Check the final alignment of tooling and components before using the C-frame press to exert pressure.

U-Joint Service

The C-frame included in this kit also may be used to service U-joints on most cars and light trucks – either on or off vehicle.

Note: This application uses the standard plug (29501) shipped with the forcing screw, not the 314392.

Disassembly

1. Remove external / internal lock rings.
2. Position C-frame around driveshaft yoke, and tighten forcing screw until first bearing is removed.
3. Position C-frame on second bearing, and tighten forcing screw until second bearing is removed.

Assembly

1. Clean dirt and oil from yoke area.
2. Align C-frame and new bearing as straight as possible over yoke.
3. Press new bearing into yoke, and install lock rings.
4. Position C-frame and second bearing as straight as possible over yoke.
5. Press new bearing into yoke, and install lock rings.

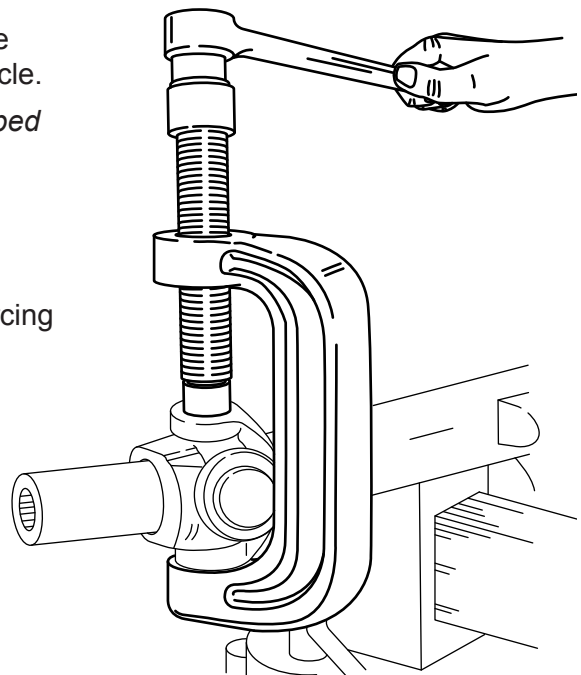

Ball Joint: Lower Rear

Application

Buick LeSabre 1986-1999
Buick Park Avenue 1991-1997
Oldsmobile 88 1985-1999
Oldsmobile 98 1985-1996
Oldsmobile LSS 1996-1999
Oldsmobile Regency 1997-1998
Pontiac Bonneville 1987-1999

Note: Remove live center plug from C-frame forcing screw; replace it with 314392 plug supplied with this kit.

Removal

1. Remove dust boot.
2. Position components as shown.
3. Turn forcing screw until plug meets ball joint or adapter. Check alignment of all components.
4. Tighten forcing screw until ball joint is removed.

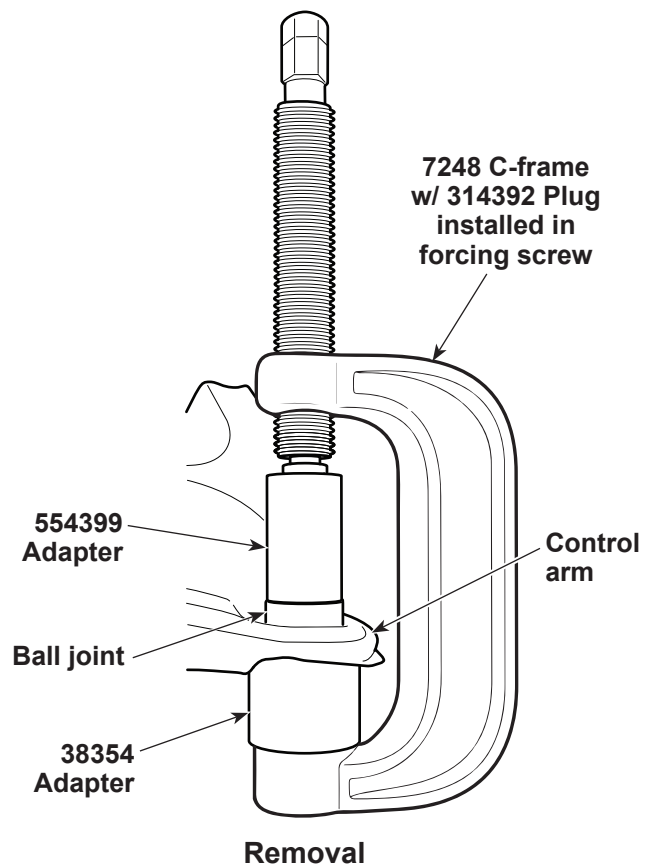

Installation

1. Clean ball joint bore in control arm.
2. Insert new ball joint as straight as possible into control arm.
3. Position components as shown.
4. Turn forcing screw until plug meets ball joint or adapter. Check alignment of all components.
5. Tighten forcing screw until ball joint is firmly seated.
6. Install dust boot.

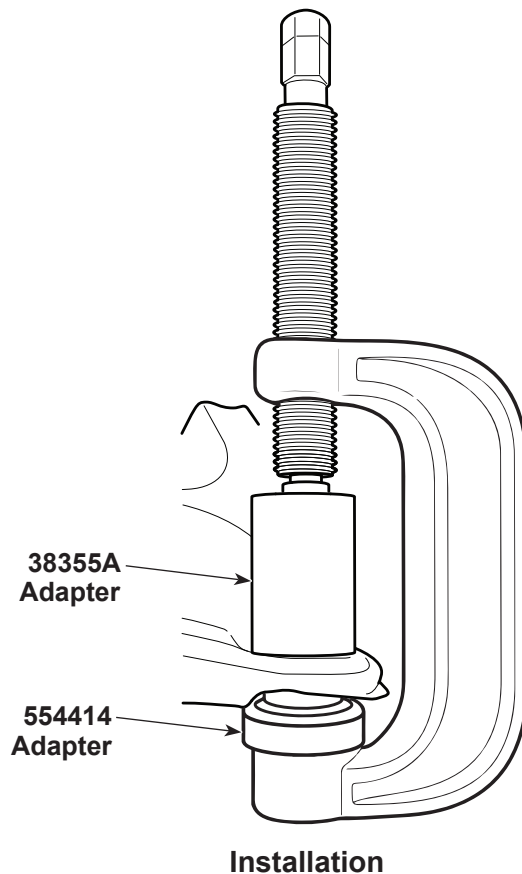

Ball Joint: Lower Front

Application

Buick Roadmaster 1991-1996
Cadillac Fleetwood 1993-1996
Chevrolet Camaro 1970-2002
Chevrolet Caprice 1977-1996
Chevrolet Impala 1994-1996
Pontiac Firebird 1970-2002

Note: Remove live center plug from C-frame forcing screw; replace it with 314392 plug supplied with this kit.

Removal

1. Remove dust boot.
2. Position components as shown.
3. Turn forcing screw until plug meets ball joint or adapter. Check alignment of all components.
4. Tighten forcing screw until ball joint is removed.

Installation

1. Clean ball joint bore in control arm.
2. Insert new ball joint as straight as possible into control arm.
3. Position components as shown.
4. Turn forcing screw until plug meets ball joint or adapter. Check alignment of all components.
5. Tighten forcing screw until ball joint is firmly seated.
6. Install dust boot.

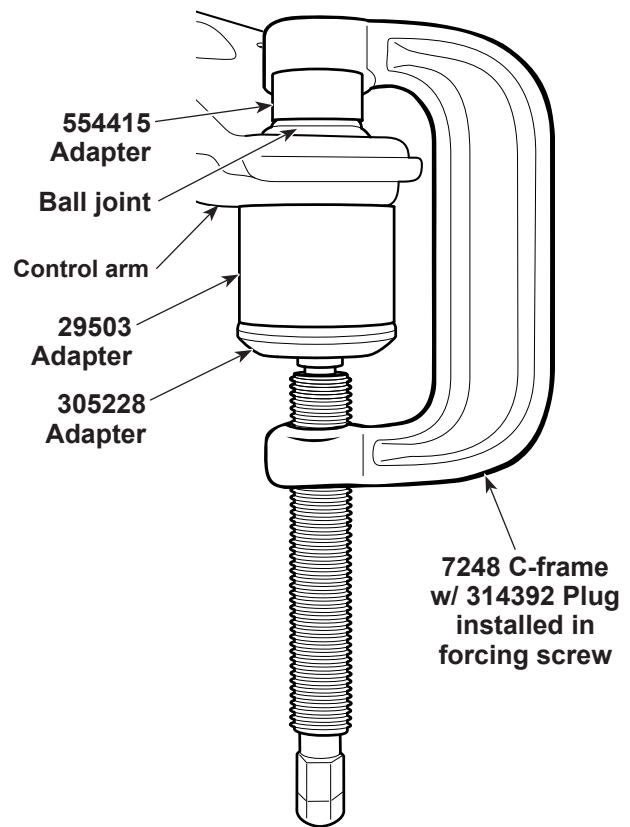

Removal

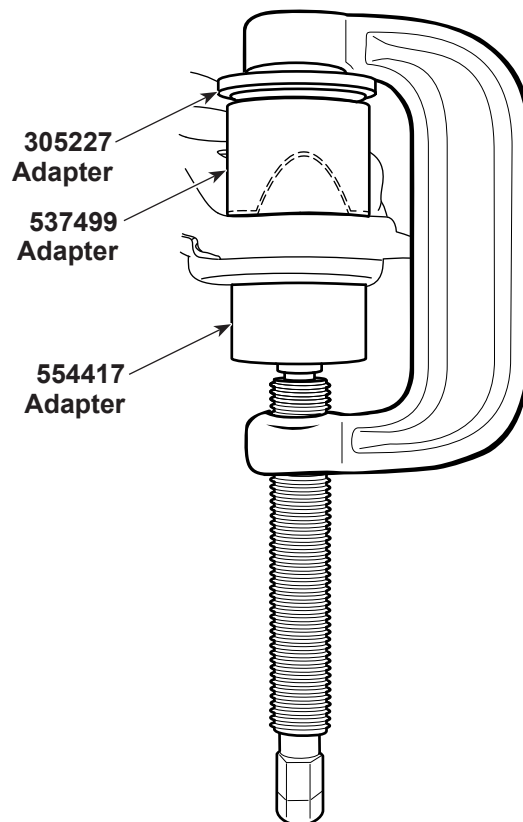

Installation

Ball Joint: Lower Front

Application

Cadillac CTS 2003-2008

Note: Remove live center plug from C-frame forcing screw; replace it with 314392 plug supplied with this kit.

Removal

1. Remove dust boot.
2. Position components as shown.
3. Turn forcing screw until plug meets ball joint or adapter. Check alignment of all components.
4. Tighten forcing screw until ball joint is removed.

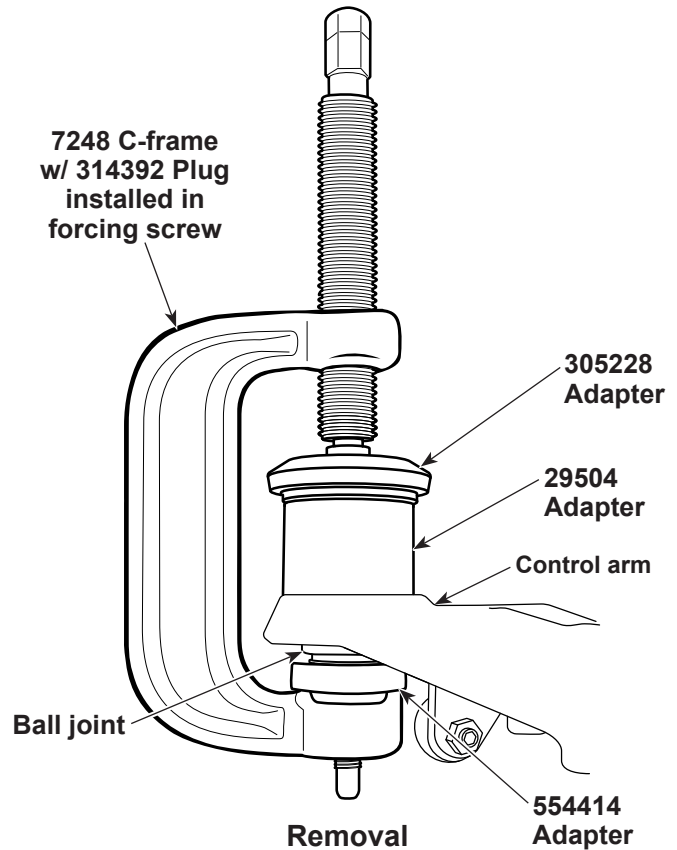

Installation

1. Clean ball joint bore in control arm.
2. Insert new ball joint as straight as possible into control arm.
3. Position components as shown.
4. Turn forcing screw until plug meets ball joint or adapter. Check alignment of all components.
5. Tighten forcing screw until ball joint is firmly seated.
6. Install dust boot.

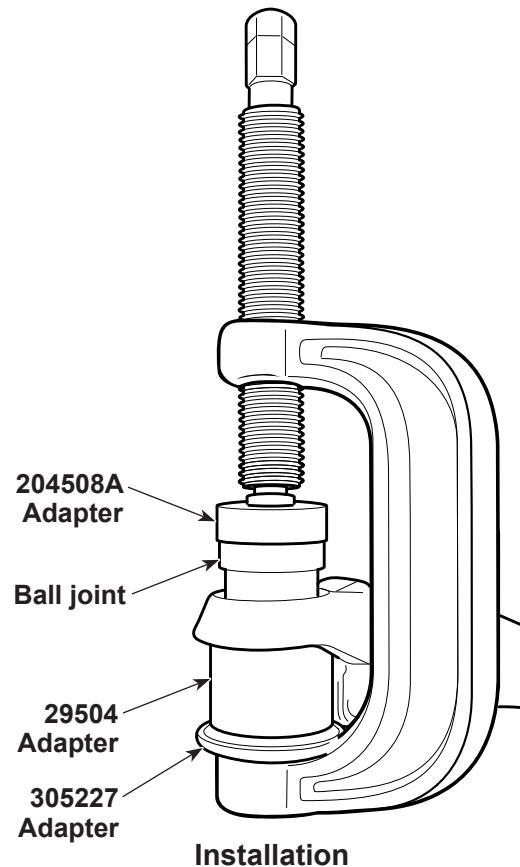

Ball Joint: Lower Front

Application

Cadillac DeVille
w/ standard-duty suspension 1996-1999

Note: Remove live center plug from C-frame forcing screw; replace it with 314392 plug supplied with this kit.

Removal

1. Remove dust boot.
2. Position components as shown.
3. Turn forcing screw until plug meets ball joint or adapter. Check alignment of all components.
4. Tighten forcing screw until ball joint is removed.

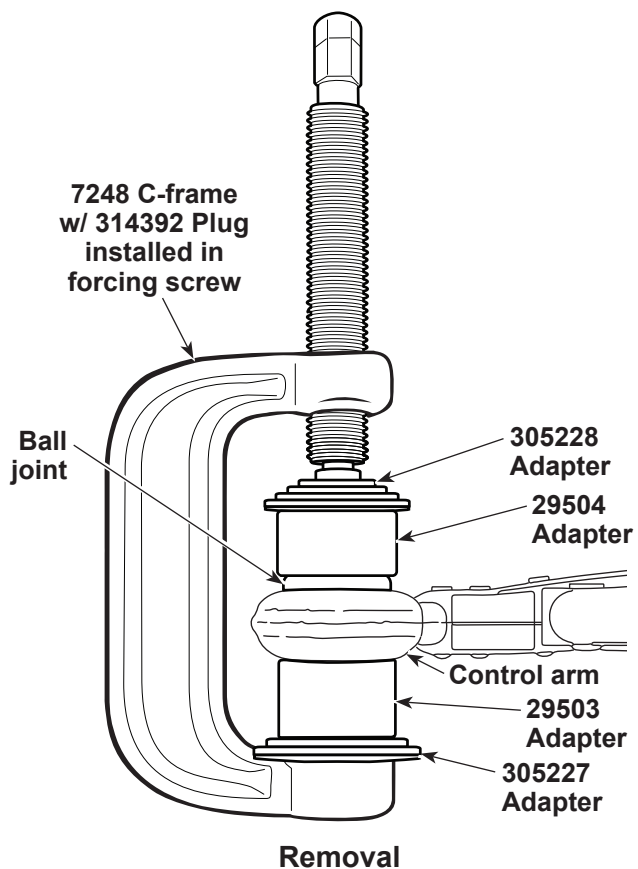

Installation

1. Clean ball joint bore in control arm.
2. Insert new ball joint as straight as possible into control arm.
3. Position components as shown.
4. Turn forcing screw until plug meets ball joint or adapter. Check alignment of all components.
5. Tighten forcing screw until ball joint is firmly seated.
6. Install dust boot.

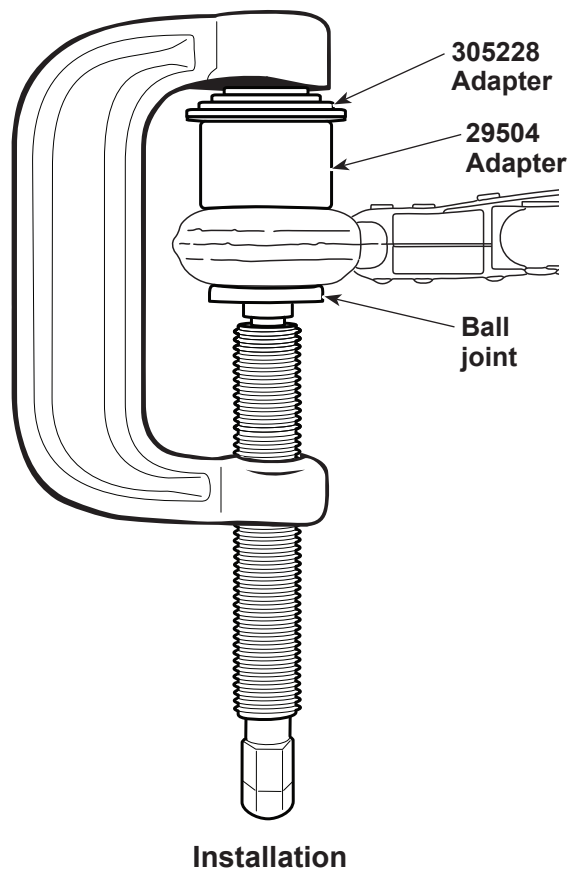

Ball Joint: Lower Front

Application

Cadillac DeVille
w/ heavy-duty suspension 1997-2005
Cadillac DTS 2006-2011

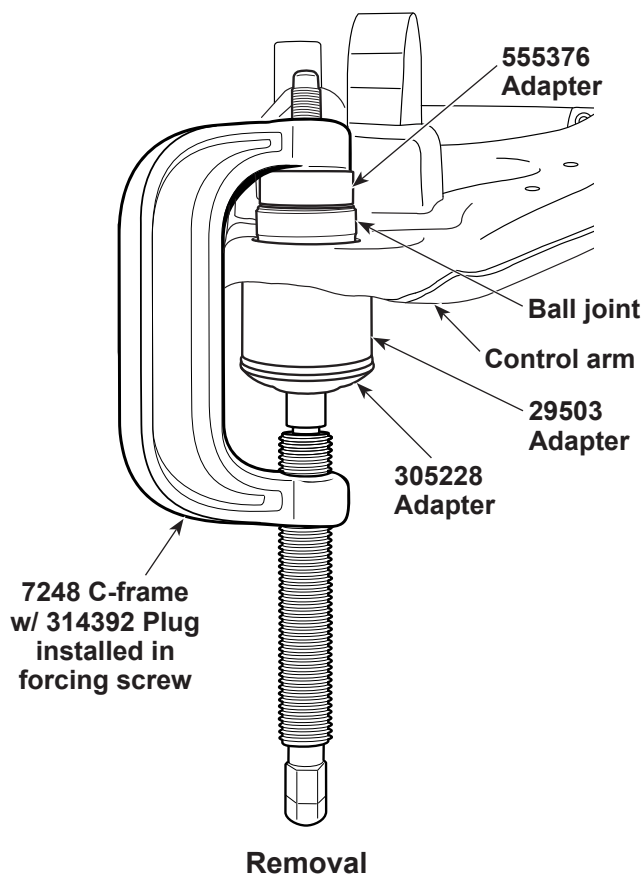

Note: Remove live center plug from C-frame forcing screw; replace it with 314392 plug supplied with this kit.

Removal

1. Remove dust boot.
2. Position components as shown.
3. Turn forcing screw until plug meets ball joint or adapter. Check alignment of all components.
4. Tighten forcing screw until ball joint is removed.

Installation

1. Clean ball joint bore in control arm.
2. Insert new ball joint as straight as possible into control arm.
3. Position components as shown.
4. Turn forcing screw until plug meets ball joint or adapter. Check alignment of all components.
5. Tighten forcing screw until ball joint is firmly seated.
6. Install dust boot.

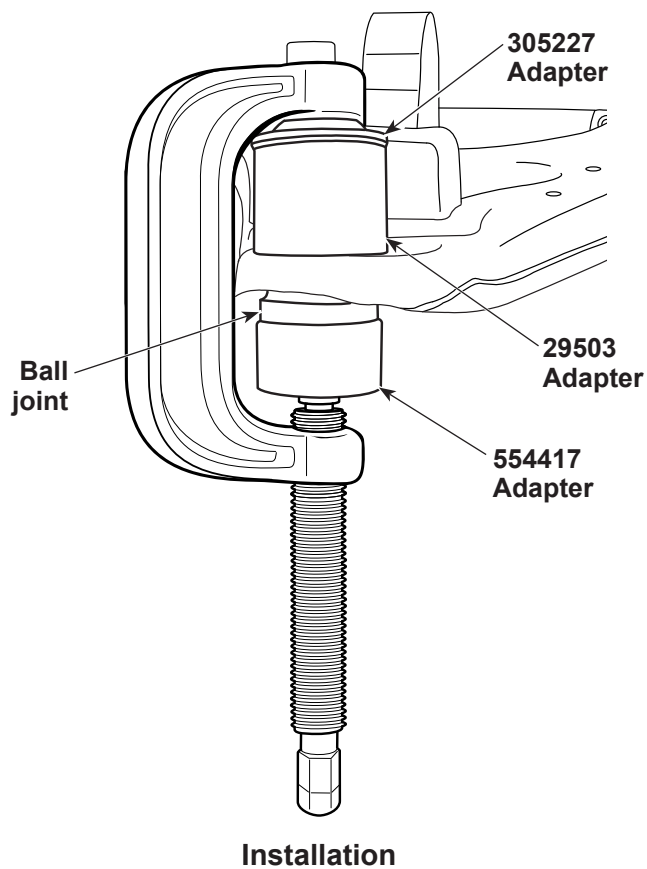

Ball Joint: Lower Front

Application

Cadillac XLR 2007-2009
Cadillac XLR-V 2006-2009
Chevrolet Corvette 1997-2011
Pontiac Solstice 2006-2007

Note: Remove live center plug from C-frame forcing screw; replace it with 314392 plug supplied with this kit.

Removal

1. Remove dust boot.
2. Position components as shown.
3. Turn forcing screw until plug meets ball joint or adapter. Check alignment of all components.
4. Tighten forcing screw until ball joint is removed.

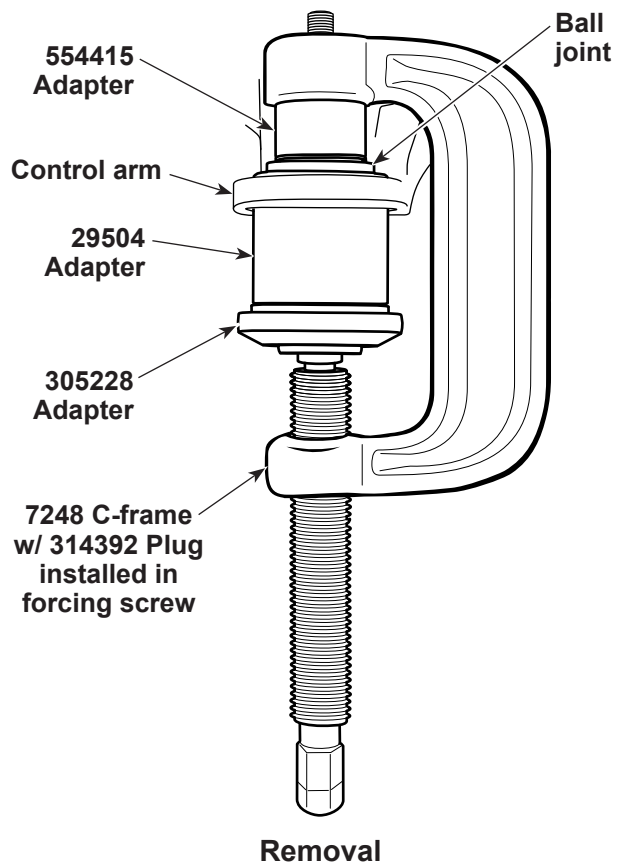

Installation

1. Clean ball joint bore in control arm.
2. Insert new ball joint as straight as possible into control arm.
3. Position components as shown.
4. Turn forcing screw until plug meets ball joint or adapter. Check alignment of all components.
5. Tighten forcing screw until ball joint is firmly seated.
6. Install dust boot.

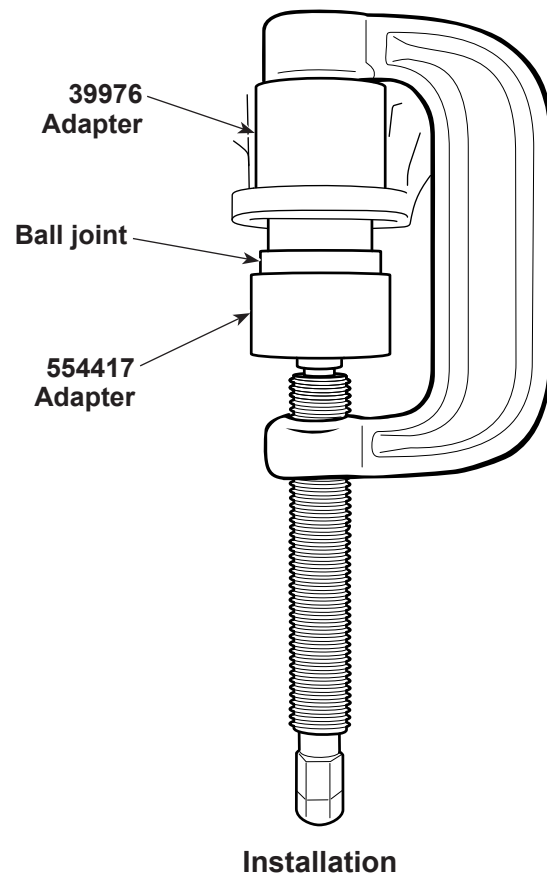

Ball Joint: Upper Front

Application

Cadillac XLR 2004-2009
Cadillac XLR-V 2006-2009
Chevrolet Corvette 1997-2011

Note: Remove live center plug from C-frame forcing screw; replace it with 314392 plug supplied with this kit.

Removal

1. Remove dust boot.
2. Position components as shown.
3. Turn forcing screw until plug meets ball joint or adapter. Check alignment of all components.
4. Tighten forcing screw until ball joint is removed.

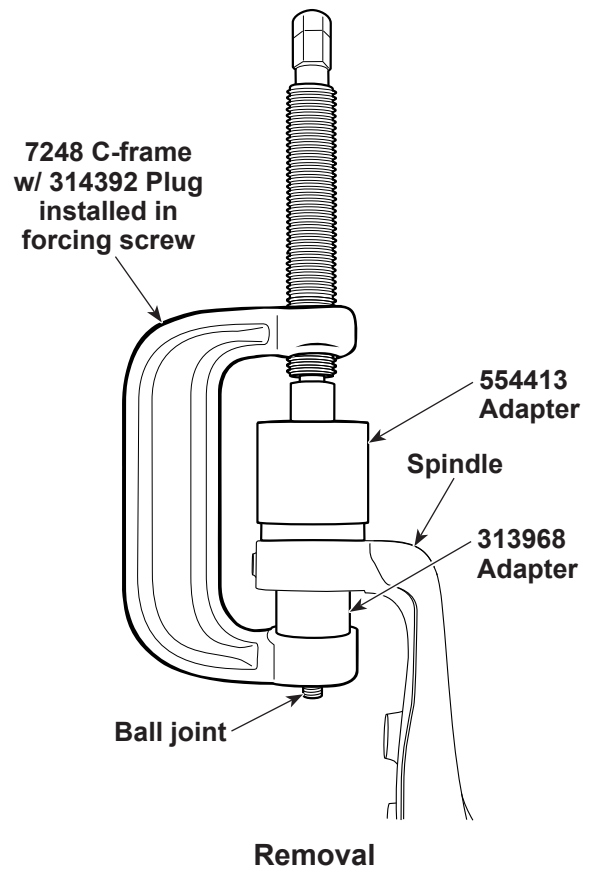

Installation

1. Clean ball joint bore in spindle.
2. Insert new ball joint as straight as possible into spindle.
3. Position components as shown.
4. Turn forcing screw until plug meets ball joint or adapter. Check alignment of all components.
5. Tighten forcing screw until ball joint is firmly seated.
6. Install dust boot.

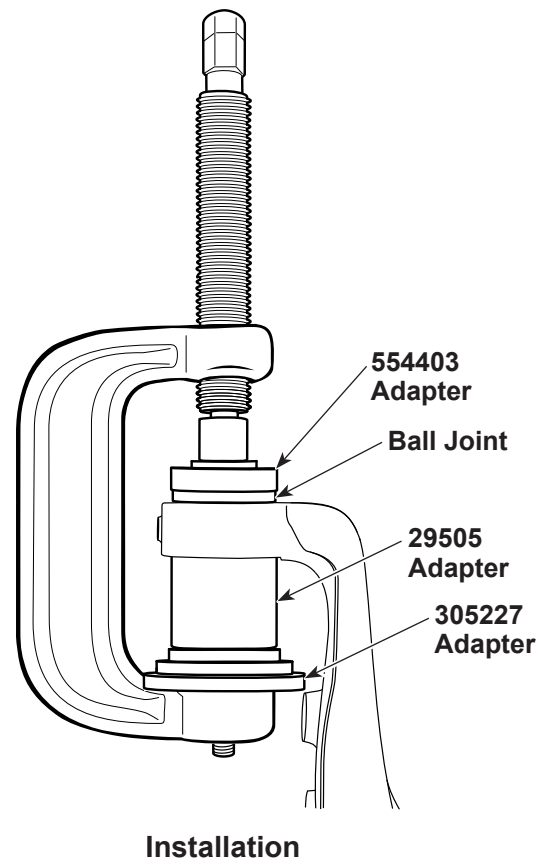

Ball Joint: Lower Front

Application

Chevrolet Corvette 1984-1996

Note: Remove live center plug from C-frame forcing screw; replace it with 314392 plug supplied with this kit.

Removal

1. Remove dust boot.
2. Position components as shown.
3. Turn forcing screw until plug meets ball joint or adapter. Check alignment of all components.
4. Tighten forcing screw until ball joint is removed.

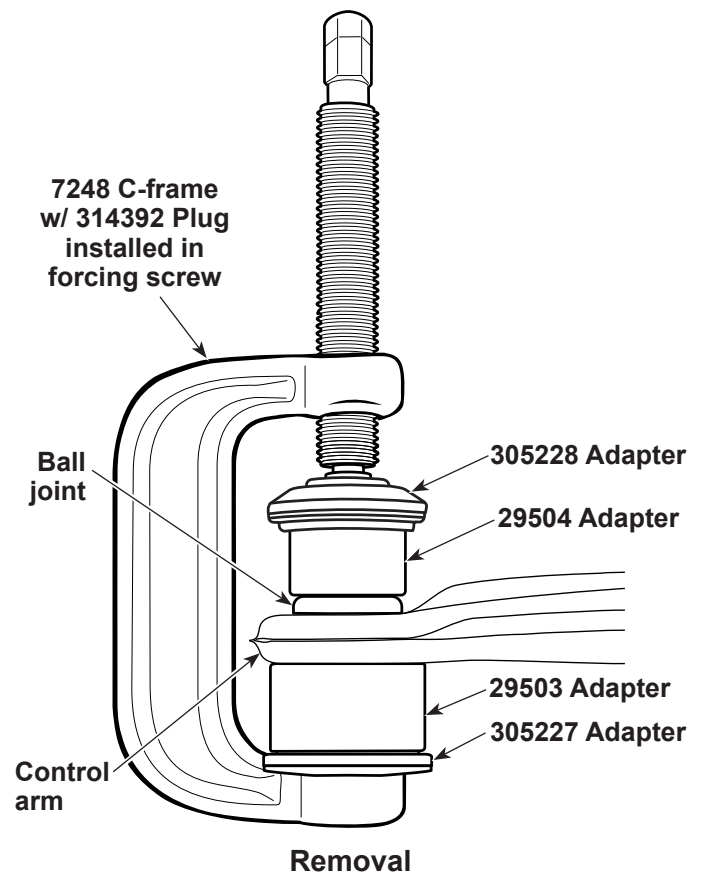

Installation

1. Clean ball joint bore in control arm.
2. Insert new ball joint as straight as possible into control arm.
3. Position components as shown.
4. Turn forcing screw until plug meets ball joint or adapter. Check alignment of all components.
5. Tighten forcing screw until ball joint is firmly seated.
6. Install dust boot.

