

MOTOR GUARD CORPORATION

MODEL M-800 SHOP AIR MANAGEMENT SYSTEM

INSTALLATION

The M-800 Shop Air Management System combines a high efficiency (40 Micron) particulate and water removal filter, an effective (0.9 Micron) oil removal filter and a high-flow, balanced valve regulator into a first line of defense for your compressed air system.

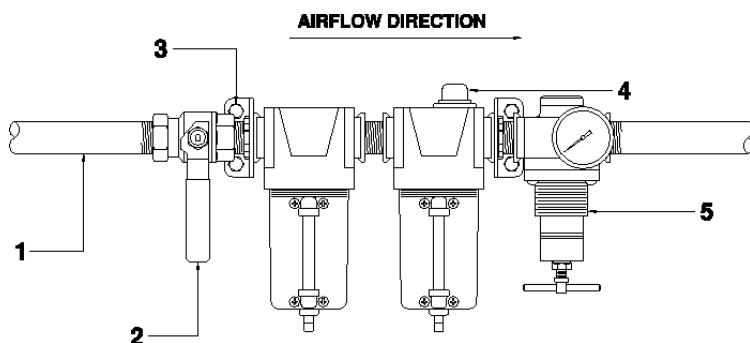

FEATURES

- Highly visible liquid level indicator
- Mechanical service indicator turns from white to orange when oil element needs to be replaced
- Reliable float type automatic drain
- High capacity bowls
- Full adjustment over pressure range

SPECIFICATIONS

Maximum Airflow:	120 CFM
Operating Temperature Range:	40 - 120 F
Maximum Inlet Pressure:	250 PSI
Outlet Pressure Range:	0-125 PSI

Install unit in main air supply line (1) with at least 20 feet of supply line between unit and compressor. Failure to maintain this distance will cause excessive water vapor to pass through unit. Unit is designed for installation in a 3/4" line, use appropriate fittings for installation in other line sizes. Apply pipe thread compound to male thread connections. Before installing unit, relieve upstream pressure completely. Install unit level and in direction of airflow as noted. Mounting brackets are designed for 1/4" hardware (3). Unit should be mounted to a rigid structure and should not be supported by the supply line.

WARNING: This product is intended for use in industrial compressed air systems only. Do not install where pressures or temperatures can exceed those listed above.

Before pressurizing, be sure bowls are turned fully clockwise. Pressurize slowly to avoid high-pressure surge.

Water vapor may pass through this system and condense into liquid downstream. For maximum protection install a Motor Guard air dryer as close as possible to the work area.

OPERATION

Open service valve (2) fully so that handle is parallel to inlet pipe. Turn T-handle on regulator (5) clockwise to increase air pressure, counter-clockwise to decrease. To reduce pressure setting, first reduce pressure to a setting lower than desired, then increase to the desired setting.

Inspect daily for leaks.

Check level of accumulated liquid daily.

Check service indicator (4) daily and replace element when indicator is approximately one-half orange/white in color.

When service indicator shows approximately one-half orange/white, oil element should be replaced to avoid excessive pressure drop. Regulator should be disassembled, cleaned and serviced periodically.

580 CARNEGIE STREET
MANTECA, CA 95337

1-800-227-2822
FAX 209-239-5114

www.motorguard.com

Rev 11/07 33140

MAINTENANCE

WARNING: Shut off air supply and drain residual pressure before attempting to service any part of the system!

Filter Replacement

M-810 Particulate Filter

Turn bowl counter-clockwise and remove. Unscrew baffle and remove filter element. Clean accumulated sludge and debris from bowl and baffle. Inspect O-ring for damage and replace if necessary. Install new filter element and replace baffle and bowl.

M-820 Coalescing Filter

Turn bowl counter clockwise and remove. Unscrew baffle and remove oil element. Clean accumulated sludge and debris from bowl and baffle. Inspect O-ring for damage and replace if necessary. Install new oil element and replace bowl.

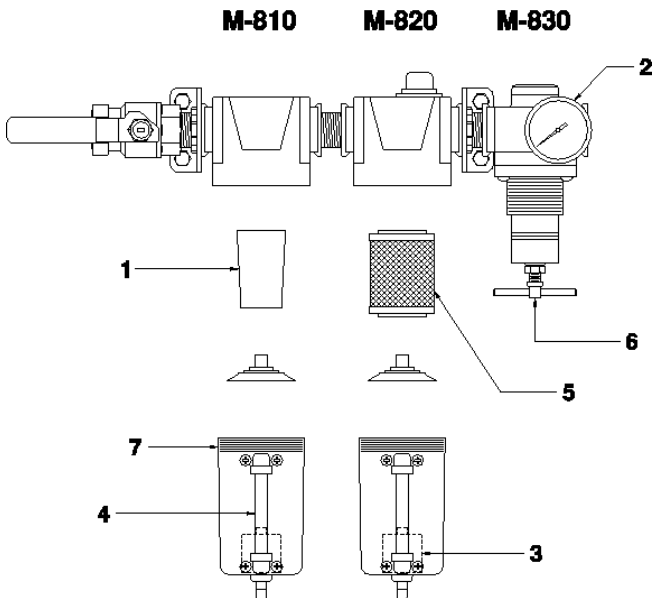

Replacement Parts

Key	Part No	Description
1	MP0020	Element, Particulate, 40 micron
2	RG4045	Gauge, 2", 160 psi
3	AS4054	Automatic Drain Kit
4	RK4205	Sight Glass
5	EL4022	Element, Coalescing, .9 micron
6	MP0026	Regulator Diaphragm Kit
7	RK4048	O-Ring, Bowl

LIMITED WARRANTY

Motor Guard Corporation assumes the responsibility of providing equipment that is free from defects in workmanship and material. Should this product fail due to a defect in workmanship or material, Motor Guard Corporation will repair or, at its option, replace the product without charge, other than the transportation charges, provided that the product is returned to the factory, transportation prepaid, within one year of the date of purchase. Please contact Motor Guard Corporation for return authorization and shipping instructions.

This limited warranty does not cover damage to the product due to neglect, misuse or accident, nor does it cover any loss, damage or expense, either direct, indirect or consequential, arising from the non-function of this product. This limited warranty notice replaces any other warranty information, implied or otherwise, enclosed with this product or appearing in literature referring to this product.

Build a Complete Shop Air System with These Air Management Products from Motor Guard

