



Spray Guns | Cup Systems | Breathing Protection | Filtration | Accessories



Eurotech Spray Products Ltd.

Exclusive, independent importer and distributor of SATA products in Canada

Table of Contents

Table of Contents	2-3
General Information	4-5
Application Recommendations for Spray Guns.....	6-7
Cutaway Model of SATAjet 5000 B	8
Application Recommendations for Cup Systems	9
Application Recommendations for Breathing Protection	10
Application Recommendations for Filtration Technology	11
Application Recommendations for SATA Accessories.....	12
Application Recommendations for Eurotech Pumps, Tanks & and Accessories.....	13
Spray Guns	15
SATAjet® 5000 B RP® /HVLP	16-17
SATAjet® 4000 B RP® /HVLP	18-19
SATAmijet® 4400BRP® /HVLP	20-21
SATAjet® 3000 K RP® /HVLP	22-23
SATAjet® 3000 K spray mix	24-25
SATAjet® 1000 B RP® /HVLP	26-27
SATAjet® 1000 B Lignum Edition RP® /HVLP	26-27
SATAjet® 1000 K RP® /HVLP	28-29
SATAjet® 1000 K Specialty Spray Guns	30-31
SATAjet® 1000 H RP®	32-33
SATAjet® 100 BF RP® /HVLP/SATAjet® 100 B P	34-35
SATAmijet® 1000 K RP® /HVLP	6-37
SATAmijet® 1000HRP® /HVLP	38-39
SATAjet® 20 B	40-41
SATAgraph™ 1/2/3	42-43
SATAgraph™ 4	44-45
Nozzle Sets for Older Model SATA Spray Guns	46-47
SATAjet® 3000 B RP® /HVLP	48
SATAjet® 90-2RP® /HVLP	49
SATAjet® 2000 B RP® /HVLP	50
SATAmijet® 3000 B HVLP	51
SATAjet® KLC RP® /HVLP / SATAjet® KLC P	52
SATAjet® B (SATAjet® GR)	53
SATA® LM 2000 B RP® /HVLP	54
SATA® LM 2000 K RP® /HVLP /SATA® LM 2000 H RP®	55
Spare Parts for Gravity Fed SATA Spray Guns	56-57
Spare Parts Pressure Fed Guns	58-59
Nozzle Extensions for Pressure Fed Guns	60-61
SATA® adam 2 & SATA® air micrometers	62-63
Accessories & Cleaning for all SATA spray guns	64-67
Viscosity Cup Conversion Chart	68
Selection guide for Auto & ROB spray guns	70-71
SATAjet® 3000 ROB RP® /HVLP	72-73
Quick change adapter SATAjet A / ROB	74-75
SATAjet® 3000 A RP® /HVLP	76-77
SATA® 1000 A RP®	78-79
SATAmijet® 1000 A / ROB RP® /HVLP.....	80-83
SATAmijet® 3000 A S / ROB HVLP	84-87
SATAjet® LPS 2000 RP®	88-89
SATAjet® 3000 A spray mix.....	90-91

Table of Contents

Cup Systems	93
SATA® RPS™ Disposable Cup System	94-95
Accessories for SATA® RPS™	96
SATA® RPS™ adapters	97
SATA® RPS™ siphon kits	98
SATA® RPS™ storage rack & SATA® RPS™ Dispenser	98-99
Gravity Flow Cups	100-102
SATA® BVD™	103
SATA® Agitator Cup	104
Breathing Protection	105
Breathing Protection w/ Activated Charcoal Belt	106
Breathing Protection w/o Activated Charcoal Belt	107
SATA® vision™ 2000	108-109
SATA® air star C™	110-111
Accessories for SATA supplied air respirators	112-113
Connections for Respirators & Belt Units	114-115
SATA® air star F™	116-117
Filtration	119
SATA® filter 414™/424™/434™/464™	120-121
SATA® filter 444™/474™/484™	122-123
SATA® filter 222™/242™/244™/284™	124-125
Accessories for SATA® filters	126-127
Filter head connections	128
SATA® filter 400 series cutaway	129
Accessories	131
SATA® cleanRCS™	132-133
SATA® dry jet™ + SATA® dry jet™ accessories	134
Rustproofing Equipment	135-137
Grit Blasting / Blow Guns	138-39
SATA® vario top spray™	140-142
Quick Couplings	143
Eurotech Pumps, Tanks and Accessories	145
Carbon Monoxide Monitors	146
Hoses	147
Paint Suits	148
Welding Blankets & Welding Gear	149
Autowriters & Big Glass Markers	150
Film Thickness Gauge	150
Masking Tape	150
Pump Bottles	150
Kneeler	150
Gun Cabinets	151
Demo Cases	151
DAA Vac	151
Piranha Pump Spare Parts	152
2.0 Litre Pressure Pot	153
10-20 Litre Pressure Pots	154-157
Pressure Tank Regulators	158-159
Pro Sencils	160-161

General Information

Eurotech Spray Products Ltd.

Exclusive, independent importer and distributor of SATA products in Canada

3636 Burnsland Rd SE 800.884.7282 toll free 800.273.7282 toll free fax
Calgary Alberta 403.287.3678 calgary 403.287.3724 calgary fax
T2G 3Z2 CANADA www.satacanada.com sales@satacanada.com



Eurotech Spray Products Ltd. reserves the right to change the terms and conditions and technical specifications of products at any time.

Terms of Sale

- Eurotech Spray Products Ltd. [hereinafter referred to as Eurotech] sells to warehouses and jobbers selling paint, spray equipment and service to the automotive, craft, industrial or wood finishing trades. Eurotech reserves the right to refuse sales to companies that do not provide full service before, during and after the sale.

Terms of Merchandise Orders

- All orders submitted must have an account number (customer ID).
- Orders may be emailed, faxed or phoned in, however Eurotech is not responsible in any way for orders not received.
- Any order submitted that has not been confirmed by Eurotech should be considered not received.
- Prices are subject to change without notice.
- Special order items may require full or partial payment in advance.
- A minimum of \$25.00 net invoice is required for orders to be processed on customer accounts. Customers in need of items not meeting this minimum must pre-pay complete order, including shipping and handling.

Exchange/Return

- All returns must have a "Return Goods Authorization Number" (RGA).
- Eurotech reserves the right to accept or deny any return after inspection.
- All products must be returned in new, resalable condition.
- Packaging materials must not be torn or damaged in any way.
- Authorized SATA Distributor is to pre-pay shipping charges for the return, or they will not be accepted.
- Eurotech is not responsible for lost or damaged returns.
- All returns must be accompanied by original invoice for proper processing.
- Products may be returned within 10 days from delivery date for full credit, provided the product has not been opened or used.
- Eurotech will make necessary stock adjustments on a 1:1 basis after 6 months from the initial sale to a new distributor.
- Special Order Equipment is not returnable.
- Once returns have been received and inspected, a re-stocking fee will apply: 15% on items purchased within the same year, 20% for items purchased the previous year. 25% for items 2+ years old, 30% for items 3+ years old.
- Eurotech limits product returns to a maximum of 3% of the previous year's cumulative purchases.
- Equipment that has been used, discontinued in production, or mishandled is considered not returnable.
- This Return Policy shall not apply to products shipped in error by Eurotech.

General Information

Warranty/Repair

- All equipment in need of general or warranty repair, must be accompanied by a 'Repair Order Form', issued by Eurotech, and filled out by the customer.
- Warranty is only granted in-house by Eurotech trained technicians.
- All repairs, upon arrival at Eurotech, are inspected and diagnosed. A quote is prepared and sent to customer with diagnostics and a purchase order request. no repairs are done without express authorization from the customer.
- SATA offers a one (1) year warranty on all *major equipment. Some products have an additional two (2) year warranty offered at no charge when new SATA equipment is registered online at www.satacanada.com. See back page of this Catalogue for Premium Warranty Information.
- All general and warranty repairs must be shipped, freight-paid to Eurotech, in compliance with the Exchange/Return policies listed.
- Proof of purchase date, along with registered extended warranty card, (when/if applicable) must accompany all equipment sent in for warranty work. If customer cannot prove purchase date and/or proof of extended warranty registration, warranty work will not be granted.
- Warranty is not granted on equipment that has been mis-used or tampered with. Correct operating procedures for all *major equipment are packaged with equipment or can be located online at www.satacanada.com.

Shipping Terms









- Individual orders of \$2,000.00 (or more) net invoiced are shipped carriage paid to a single destination within Canada. All pre-paid orders are shipped freight on board ground delivery with the courier of Eurotech's choice.
- Pre-paid amount does not include add-on items after invoicing, multiple purchase orders, express shipments or airfreight.
- Freight claims must be filed within three (3) days from receipt of merchandise.
- Freight charges for all returns, including repairs, are at the customer's expense.

Payment Terms

- General Terms for all clients are: 1-10/N-30
- To ensure proper credit to your account, account number and invoice number(s) with payment are required.
- Customers are allowed 1% prompt payment discount if payment is received no later than the 10th of the month following the month of purchase.
- Equipment returned for credit is not eligible for a 1% discount. [Customers will be re-invoiced - no exceptions.]
A 1.5% finance charge (18% per annum) will be assessed on all accounts over 30 days past due.
- In cases of NSF cheques: customer will be assessed a \$40.00 fee per cheque returned and marked "non-sufficient funds". The same fee applies to stop payment cheques tendered for merchandise delivered or services rendered.
- Accounts 60 days past due and/or accounts continuously past due are subject to loss of open account privileges and will be placed on prepayment status.
- Any costs incurred to collect monies due to Eurotech by a collection agency will be added to the balance due.



*Any SATA product designed to operate as-is out of box/packaging. Warranty is not granted on small or replacement parts, nor are operating instructions included with these items. SATA 3-year premium warranty (1 + 2 = 3 years) is only offered on equipment that is sold with the registration card included in packaging. No exceptions apply.

Application Recommendations for Spray Guns

1. High Performance Spray Guns		
Spray gun type	Fields of applications	Operating Mode
<p>SATAjet 5000 B HVLP/ RP Page 16 17</p> 	<p>For top coat applications meeting the highest requirements in terms of color match precision, uniform distribution and gloss. Ideally suited for car refinishing, interior design, wood coating and the furniture industry.</p>	<ul style="list-style-type: none"> • Optionally available in HVLP low pressure or optimised high pressure RP technology • Round/flat spray control • Material flow control • Air micrometer • Gravity flow cup with QCC connection • Optional feature: integrated digital pressure gauge
<p>SATAjet 4000 B HVLP/ RP Page 18 19</p> 	<p>For top coat applications meeting the highest requirements in terms of color match precision, uniform distribution and gloss. Ideally suited for car refinishing, interior design, wood coating and the furniture industry.</p>	<ul style="list-style-type: none"> • Optionally available in HVLP low pressure or optimised high pressure RP technology • Round/flat spray control • Material flow control • Air micrometer • Gravity flow cup with QCC connection • Optional feature: integrated digital pressure gauge
<p>SATAjet 3000 K HVLP/ RP Page 22 23</p> 	<p>Ideally suited for coating large areas, e.g. on commercial vehicles, or application of textured paints with air atomising technology.</p>	<ul style="list-style-type: none"> • To be used in combination with paint pressure tanks or low pressure pumps, i.e. SATA vario top spray double membrane pump • Same functional features as the SATAjet 5000 B
<p>SATAjet 3000 K spray mix Page 24 25</p> 	<p>Ideally suited for coating large areas in the furniture, wood and metalworking industry</p>	<ul style="list-style-type: none"> • To be used in combination with high pressure air assisted pumps (max. 3625 psi), i.e. SATA shark or SATA dolphin • Round/flat spray control • Air micrometer
2. Universal Spray Guns for Industry		
<p>SATAjet 1000 B HVLP/ RP Page 26 27</p>  <p>SATAjet 1000 H RP Page 32 33</p> 	<p>For the application of a wide array of different materials, from primer materials and paint to glue and separating agents in craft and industry. A comprehensive range of accessories is available for this spray gun, including extensions, slit nozzles, and nozzle set-ups for glue application.</p>	<ul style="list-style-type: none"> • Optionally available in HVLP low pressure or optimised high pressure RP technology. • Round/flat spray control • Material flow control • Air micrometer • Gravity flow cup with QCC connection
<p>SATAjet 1000 K HVLP/ RP Page 28 29</p> 	<p>Same field of application as the SATAjet 1000 B, but for coating larger areas.</p>	<ul style="list-style-type: none"> • To be used in combination with paint pressure tanks or low pressure pumps, i.e. SATA vario top spray • Same functional features as the SATAjet 1000 B
<p>SATAjet 1000 K Specialty Guns K D, Slit Nozzle KK HKU Rustproof Page 30 31</p> 	<p>Specialty spray guns for the application of adhesives, textures and rustproofing material</p>	<ul style="list-style-type: none"> • To be used in combination with paint pressure tanks or low pressure pumps, i.e. SATA vario top spray • Same functional features as SATAjet 1000 B

Application Recommendations for Spray Guns



2. Universal Spray Guns for Industry continued

<p>SATAminijet 1000 K HVLV/RP Page 36 37</p>		<p>Same field of application as the SATAjet 100 B gravity fed version, but for coating large areas.</p>	<ul style="list-style-type: none"> • To be used in combination with paint pressure tanks or low pressure pumps, i.e. SATA vario top spray • Same functional features as SATAjet 1000 B
<p>SATAminijet 1000 H HVLV/RP Page 38 39</p>		<p>Same field of application as the SATAjet 1000 B gravity fed version, but for coating large areas.</p>	<ul style="list-style-type: none"> • To be used in combination with paint pressure tanks or low pressure pumps, i.e. SATA vario top spray • Same functional features as the SATAjet 1000 B

3. Spray Guns for Primer and Filler Applications

Spray gun type	Fields of applications	Operating Mode
<p>SATAjet 100 B F HVLV/RP Page 34 35</p>	<p>Application of primer and filler materials in craft and industry</p>	<ul style="list-style-type: none"> • Optionally available in HVLV low pressure or optimised high pressure RP technology • Round/flat spray control • Material flow control • Air micrometer • Gravity flow cup with QCC connection
<p>SATAjet 100 B P Page 34 35</p>	<p>Application of polyester filler and sprayable putty</p>	<ul style="list-style-type: none"> • High pressure spray gun with shortened air cap horns, without air micrometer • Same functional features as SATAjet 100 B F, without air micrometer

4. Universal Spray Guns for Industry

<p>SATAminijet 4400 B HVLV/RP Page 20 21</p>		<p>Spray gun for small paint jobs, e.g. spot repair and touch-ups in the automotive sector or custom design in craft and industry. Also perfectly suitable for the application of separating agents.</p>	<ul style="list-style-type: none"> • HVLV low pressure atomisation • Round/flat spray control for left and right handed painters • Reusable cup with mini QCC connection • Material flow control • Air micrometer
<p>SATAjet 20 B Page 40 41</p>		<p>Spray gun for custom design in craft and industry, calligraphy, patination</p>	<ul style="list-style-type: none"> • Exclusively available with round spray nozzles • Reusable cup
<p>SATAgraph 1/2/3 Page 42 43</p>		<p>Spray guns for custom design in craft and industry</p>	<ul style="list-style-type: none"> • Airbrush guns with gravity or suction cups • Exclusively available with round spray nozzles • With double-action function
<p>SATAgraph 4 B/S/H Page 44 45</p>		<p>Spray guns for custom design in craft and industry</p>	<ul style="list-style-type: none"> • Airbrush guns with gravity, side or suction cups • Exclusively available with round spray nozzles • With double-action function • Reversing nozzle for fine detail work

5. Automatic & Robotic Guns

Spray gun type	Fields of applications
<p>5.1 SATA automatic and robotic Page 69 - 91</p>	<p>Industrial application of varying amounts of materials. Please inquire for specific usage and combinations available</p>

Cutaway Model SATAjet 5000 B

Cutaway model SATAjet 5000 B

Robust air cap of chrome-plated brass with new **QC™** air cap thread for quick change with only one turn.

Air cap ring:

green = HVLV technology

blue = RP technology

Fluid tip and paint needle made of corrosion resistant stainless steel.

Material passage (red).

Air passage (blue).

Replaceable air distribution insert.

Fluid tip sealing ensuring minimal cleaning effort and safe colour change.

Low maintenance, self-adjusting seals at air piston and paint needle

Ergonomically designed trigger with paint needle protection ensuring increased lifetime of the paint needle packing.

Easy clean corrosion-resistant pearlchrome™ gun surface.

Option: Digital pressure display for perfect colour match.

CCS™ – Colour Code System. For the convenient identification of your spray gun.

QC™ – Quick Cup Connector. Ensures quick and clean cup changes as well as easy cleaning.

Gun suspension hook for convenient storage.

Control elements can be perfectly adjusted even when wearing gloves.

Improved material flow control with counter nut.

Air micrometer for the adjustment of the atomization air. Highest precision with digital pressure gauge (optional).

Spray fan control allowing fine adjustment with a half turn only

Ergonomically shaped gun handle.









Special internal nickel plating

Air connection G 1/4 male thread with optionally available swivel joint.

1 + 2 = 3 **Warranty.** Top quality is not enough - we guarantee it: for three years!



See Page 162 for details!

Application Recommendations for Cup Systems

Cup Systems		
Cup type / capacity	Fields of application	Connection
<p>SATA RPS mixing cup 0,3 l / 0,6 l / 0,9 l Page 94 95</p> 	<p>Disposable gravity cup with paint sieve for frequent colour changes. For mixing, painting and storing. No adapters required for all current SATA spray guns.</p>	<ul style="list-style-type: none"> • With QCC bayonet lock and male thread • Adapters for older SATA spray gun models and spray guns from other manufacturers are available
<p>SATA RPS Adapters Page 97</p> 	<p>Use RPS adapters for spray guns without QCC connections. Also for paint guns of other spray gun manufacturers</p>	
<p>SATA RPS Dispenser Page 99</p> 	<p>RPS dispenser to keep all your RPS disposable cups, lids, and sieves in an organised location.</p>	<ul style="list-style-type: none"> • Flat wall mounted version • Rotating wall mounted version • Rotating bench or floor mounted version
<p>SATA reusable cup 63 ml / 15 ml / 0.3l / 0.6 l / 0.75 l / 1.0 l Page 100 101</p> 	<p>Reusable plastic or aluminum gravity flow cups for SATA spray guns</p>	<ul style="list-style-type: none"> • With QCC lock and male thread or with female thread for older SATA spray gun models
<p>SATA glass reusable cup 25 ml Page 102</p> 	<p>For various air brush or craft guns where frequent colour changes are required.</p>	<ul style="list-style-type: none"> • Varies
<p>SATA cup adapters Page 102</p> 	<p>Adapters to retrofit SATA spray guns to various cup styles.</p>	
<p>SATA BVD adaption kit 0,7 l Page 103</p> 	<p>Pressurised reusable aluminum gravity flow cup for the application of high-viscosity materials</p>	<ul style="list-style-type: none"> • With QCC connection and male thread or with female thread for older SATA spray gun models
<p>SATA agitator cup 0,7 l Page 104</p> 	<p>Reusable aluminum gravity flow cup with integrated agitator for the application of materials with settling components, e.g. effect paints. Agitator with air regulation valve for speed adjustment</p>	<ul style="list-style-type: none"> • With QCC connection and male thread

Application Recommendations for Breathing Protection

Breathing Protection

Respirator type	Fields of application/function
SATA vision 2000 Page 106 107 108 109 114 115	 Full face respirator protects the head incl. hair and neck / independent from ambient air (air supplied). Please note the legal requirements of your region.
SATA air star C Page 107 110 111	 Half mask protects mouth and nose / independent from ambient air (air supplied). Protective goggles are recommended. Please note the legal requirements of your region.
SATA air star F Page 116 117	 Half mask to protect the mouth and nose area / dependent on ambient air (filtering mask). With pre-filter disks to extend the lifetime of the filter cartridges. It is recommended to wear protective goggles. Please note the legal requirements of your region.

Cutaway SATA vision 2000



Head/chest cover with Velcro closure; breathable, solvent-resistant, lint-free and flame retardant.

Adjustment screw allowing to fix the visor.

Sweat band made of micro fibre velour, dermatologist tested; easy to replace to ensure highest hygiene standards; with foam insert for enhanced wearer comfort.

Special single visor foil to prevent reflections and distortions leading to colour deviations; quick and easy to change.

Breathing air hose with sound adsorber for fresh air supply.

Individually adjustable head strap to allow greater wearer comfort.

Lightweight, robust liftable visor.

Hygienic quick exchange hood inlays.

■ **SATA® Belt Units**
 Adjustable and cushioned;
 a) with activated charcoal filter to provide quality breathing air.
 b) Industrial belt unit

■ **SATA® air warmer**
 Adjustable breathing air warmer to increase the temperature by max. approx. 55° F, attaches to the belt unit.

■ **SATA® top air™**
 Breathing air humidifier for a comfortable breathing climate, attaches to the belt unit.

Sound adsorber

Application Recommendations for Filtration Technology

Filtration Technology

Filter type

SATA filter
424 / 434 / 444 /
464 / 474 / 484

Page 120 | 121
122 | 123



Fields of application/function

Filter units for the use in paint booths

- Ambient temperature: **up to max 120 °C**
or up to max 60 °C when using activated charcoal (3 stage)
- Modular structure of up to 3 filter stages incl. activated charcoal filter
- Meets highest requirements for high-grade compressed air (100 % technically clean air)
- Air flow: **129 cfm @ 90 psi**

SATA filter

**222 / 224 / 244 /
284**

Page 124 | 125



Filter units for the use in paint booths

- Modular structure of up to 3 filter stages incl. activated charcoal filter
- Ambient temperature: **up to max 120 °C,**
or up to max 60 °F when using activated charcoal (3 stage)
- Meets requirements for high-grade compressed air (100 % technically clean air)
- Air flow: **70 cfm @ 90 psi**

Cutaway model SATA filter 484

Large pressure adjustment screw allowing the exact regulation of the work pressure.

Maintenance free pressure regulation valve.

Air inlet G 1/2 female thread
: Air flow > 129 cfm at 87 psi
(for 400 series)

First filter stage:

■ Low maintenance cyclone separates condensate and oil droplets.

■ Sintered filter to separate particles > 5 micron; exchange interval: 6 months.

Automatic condensate discharge valve - high operating safety, low service effort.

Condensate discharge hose.

Air pressure gauge for pressure difference display (control of fine filter saturation).

Air outlet module.

Optional air outlet G 1/2 female thread.

Air outlets with ball valves and connections w/ G 1/4 male threads.

Filter housing with easy clean surface.

Second filter stage:

■ Fine filter cartridge to separate particles > 0.01 micron; separation efficiency 99.998 %; exchange interval: 6 months.

Third filter stage:

■ Activated charcoal cartridge to eliminate oil vapours when using air-supplied breathing masks and for the application of waterborne paints; Exchange interval every 3 months.

Application Recommendations for Other Devices / Accessories



1. Spray Gun Cleaning

Type of Device	Fields of application/function
2.1 SATA cleanRCS Page 132-133 	<ul style="list-style-type: none"> • Rapid cleaning system for intermediate cleaning of spray guns for quick colour changes when using disposable cups, e.g. SATA RPS • Suitable for waterborne and solvent-based paint systems

2. Dry-Blowing Systems

Type of Device	Fields of application/function
3.1 SATA dry jet 2 Page 134 	<ul style="list-style-type: none"> • Accelerated drying for surfaces painted with waterborne materials • Ideally suited for smaller paint jobs, as expensive booth heating times are being avoided • Regulates air • Quick filter changes

3. Bodyshop Equipment

Type of Device	Fields of application/function
SATA Blow Guns Page 138-139 	<ul style="list-style-type: none"> • To blow-off dust and particles - low air consumption, high efficiency • Sturdy and very durable • Different versions with special nozzle set-ups available
Grit Blasting Equipment Page 138 	<ul style="list-style-type: none"> • Grit blasting guns with hard metal insert to remove rust efficiently and quickly • Ideal for difficult to access areas. • Injector suction principle optionally with hand-held gun or large containers
Rust Proofing Equipment HKU pump Page 135 136 137 	<ul style="list-style-type: none"> • Pressurised cup spray gun for cavity preservation and underbody protection of all vehicle types. Different cavity wand systems are available. • Fine atomisation even with the application of high-viscosity materials by pressurisation with up to 150 psi

4. Material Supply for Spray Guns

Type of Device	Fields of application/function
1.1 SATA vario top spray Page 140 141 142 	<ul style="list-style-type: none"> • Pneumatically operated low pressure double diaphragm pump for air atomising pressure fed spray guns or material supply for automatic spray guns, directly out of the original container

Eurotech Accessories

Products		
Type of Device		Fields of application/function
Carbon Monoxide Monitors Page 146		AC, wall mountable and portable CO monitors meet the OSHA and NIOSH regulations. Alert at 5 ppm, both audible and visible alarm and digital readouts.
Hoses Page 147		Hoses for everything from breathing air to high pressure fluid and air/material combination hoses for painting w/ pressure fed spray guns.
Hosemate Page 147		Designed to keep your hoses from kinking at crucial painting times, also great for hanging hoses out of the way.
Paint Suits Page 148		A variety of different designs and styles; from economical to professional series . Flexible for comfort and anti-static to keep your clothes & your work clean
Welding Blankets Page 149		A variety of sizes and grades for ultimate protection
Welding Gear Page 149		Gloves and jackets in a variety of sizes and grades for ultimate protection
Autowriters & Big Glass Markers Page 150		Washable markers for glass and automotive applications to leave non-permanent identifiers.
Film Thickness Gauge Page 150		Measures the thickness of material on ferrous and non-ferrous materials
Masking Tape Page 150		For prepping in body shops.
Pump Bottles Page 150		Viton sealed pump bottles for cleaning and spraying water or chemicals.
Kneeler Page 150		Save your knees, Kneeler is here for the jobs that are hard on your knees.
Cabinets and Spray Gun Holders Page 151		Unique locking cabinets to store valuable SATA spray guns. Both single and dual door options.
Sales and Demo Support/Cases Page 151		Extremely durable cases to provide protection and ease of transporting your SATA spray guns.
Air Vac Page 151		This handy tool helps eliminate dirt & debris from your wet clearcoat or topcoat. Saves great amount of time and redo work later.
2 L Pressure Pots Page 152 - 153		High quality pressure pots for fleet and commercial use.
10-20 L Pressure Tanks Page 154 - 157		High quality pressure pots for fleet and commercial use.
Pressure Regulators Page 158 -159		Pressure regulators for pressure pots and tanks for a variety of sizes and setups.
Pro Stencils/Sticky Mickey Masking Page 160 -161		Creative high quality stencils at a great price to help your custom work look amazing



Spray Guns



SATAjet® 5000 B RP®/HVLP



This high performance spray gun is characterized by its supreme flexibility. The development process focused on creating a more versatile spray gun in regard to inlet pressure, application distance and further improved adaptability to specific requirements of the different paint systems available. The SATAjet 5000 B allows the painter to flexibly set the inlet pressure in a range between 7 and 32 psi with a gun distance between 4 to 8.5 inches, depending on material, ambient conditions and personal preferences, in order to achieve optimum finishes.

Additional enhancements include the ergonomics of the SATAjet 5000 B. The gun handle of the digital version is identical in size and shape to the standard spray gun. The air micrometer is now considerably larger and much easier to regulate. The modern design of the SATAjet 5000 B has been created in cooperation with the Porsche Design Studio, Zell am See (Austria). The SATAjet 5000 B is finished with a satin-gloss pearlchrome™ surface which is corrosion-resistant and easy to clean

SATAjet 5000 B RP

Technical Data



www.sata.com/SATAjet5000B

Inlet pressure
 Field of application: 7 psi - 35 psi
 Compliant: max. 29 psi
 Air consumption at 29 psi: 10.2 cfm
 Spray distance:
 Field of application: 4-8.5" / 10-21 cm
 Recommended: 6.5-8.5" / 17-21 cm



Nozzle Size	1.0	1.1	1.2	1.2W	1.3	1.4	1.6	1.8	2.0	2.5
-------------	-----	-----	-----	------	-----	-----	-----	-----	-----	-----

Standard with RPS disposable cup 0.3 l / 0.6 l / 0.9 l (each 1x) without swivel joint

Part No.	-	215640	209858	209866	209874	209882	209890	209908	209916	-
DIGITAL with RPS disposable cup 0.3 l / 0.6 l / 0.9 l (each 1x) without swivel joint										
Part No.	210138	210146	210153	210161	210179	210187	210195	210203	210211	-

Nozzle Set	1.0	1.1	1.2	1.2W	1.3	1.4	1.6	1.8	2.0	2.5
------------	-----	-----	-----	------	-----	-----	-----	-----	-----	-----

Part No.	210245	210252	210260	210278	210286	210294	210302	210310	210328	210336
----------	--------	--------	--------	--------	--------	--------	--------	--------	--------	--------

SATAjet 5000 B HVLP

Technical Data



www.sata.com/SATAjet5000B

Inlet pressure
 Field of application: 7 psi - 35 psi
 HVLP: max. 29 psi
 Air consumption at 29 psi; 15.2 cfm
 Spray distance
 Field of application: 4-8.5" / 10-21 cm
 Recommended: 6.5-8.5" / 17-21 cm



Nozzle Size	1.0	1.2	WSB	1.3	1.4	1.5	1.7	1.9	2.2
-------------	-----	-----	-----	-----	-----	-----	-----	-----	-----

Standard with RPS disposable cup 0.3 l / 0.6 l / 0.9 l (each 1x) without swivel joint

Part No.	210732	210740	210757	210765	210799	210823	210831	210849	210856	
DIGITAL with RPS disposable cup 0.3 l / 0.6 l / 0.9 l (each 1x) without swivel joint										
Part No.	211094	211110	211128	211136	211151	211193	211201	211219	-	

Nozzle Size	1.0	1.2	WSB	1.3	1.4	1.5	1.7	1.9	2.2
-------------	-----	-----	-----	-----	-----	-----	-----	-----	-----

Part No.	210955	210963	210971	210989	211011	211045	211052	211060	211078
----------	--------	--------	--------	--------	--------	--------	--------	--------	--------

Test Air Cap *	215996	215988	215996	215988	215988
----------------	--------	--------	--------	--------	--------

* Test Air Caps are special order items only

Spare Parts SATAjet® 5000 B

Part No./Descr.	
240	Packing, Air Piston (repair centre only)
3426	Circlip for trigger pins
10520	Spring, paint needle 12-pk
14605	Bushing, needle packing (repair centre only)
14993	Spring, needle packing (repair centre only)
15438	Paint needle packing
17152	Spring, air piston 12-pk
17897	Spring, paint needle (repair centre only)
19745	Swivel joint for NON-DIGITAL guns
23275	Packing, needle (repair centre only)
27813	Spring, air piston (repair centre only)
86843	Air piston rod
96875	Inner cup seal ring
133934	O-Ring (3x) for fan control spindle
133942	Air piston packing holder
133959	Kit, spring, pk of 3 each of #27813 & #17897
133991	Packing, Air Piston (3x)
134098	Air connection piece G1/4 male thread
140582	Sealing element (5x) for fluid tip
211391	Locking screw (3x) for air micrometer
211409	CCS-Clips, green, blue, red, black (each 1x)
211425	Air distribution ring (3x)
211433	Trigger kit
211441	Seal retainer w/ sleeve
211458	Trigger sleeve kit, just fittings
211466	Air micrometer
211474	Material flow control with counter nut
211482	Fan control knob with screw (each 2x)
211490	Air inlet connection with sleeve
211508	Air cap seal ring (5x)
211516	Seal retainer w/ sleeve & swivel joint
212282	Trigger only
213025	Spindle, cpl., for round / flat spray control
213702	Air cap ring w/ seal only, Blue - RP
213710	Air cap ring w/ seal only, Green - HVLP
213769	Battery kit

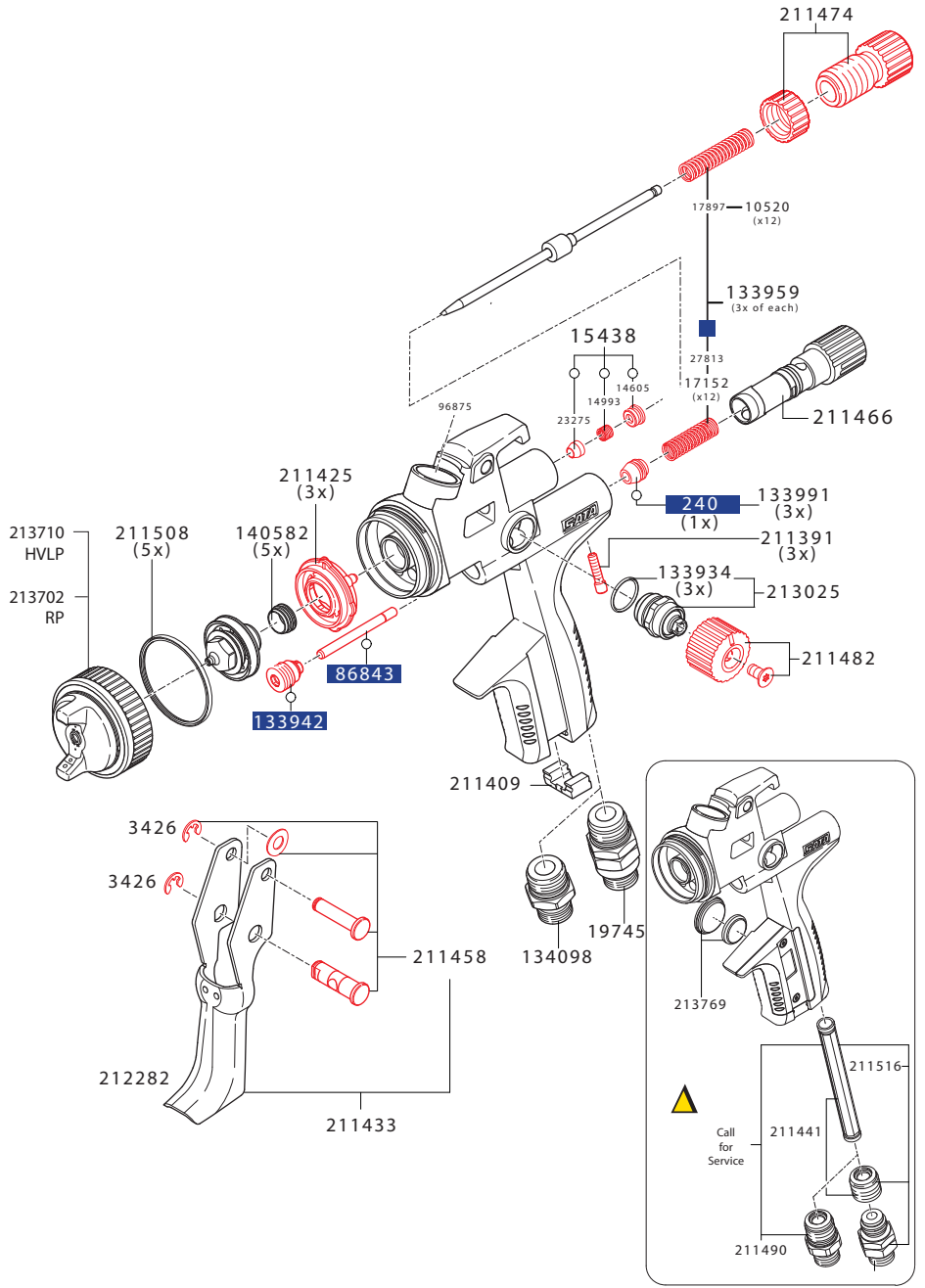

SATA adam 2 (SATAjet 5000 only)

Part No./Descr.	
211557	SATA adam 2 (psi)
211565	SATA adam 2 dock

Part No./Descr.	
211524	Tool kit
<ul style="list-style-type: none"> · Universal spanner · Cleaning brush · 198598 Combi tool · Paint strainer · Extraction tool · CCS Clip 	

WARNING

Removing the DIGITAL air inlet tube or the DIGITAL display cover VOIDS WARRANTY

Damaged DIGITAL gauges must be returned for service to ensure proper functionality

Part No./Descr.
211532
Repair kit
82552
Air piston service unit
○ 136960
Sealing kit

Technical modifications and printing errors reserved



SATAjet® 4000 B RP®/HVLP

Use for high-quality topcoat finishes. Typically used for automotive, but applicable to any other field of application. This light-weight, well balanced, ergonomic spray gun offers superb finish results. With enhanced atomization and a wider, softer fan, the uniform spray gun lay material down smoothly, delivering superior finish quality. Material distribution in both HVLP and RP models far exceeds 65% meeting all VOC legislation. With a newly designed nozzle concept, every paint system is safely and perfectly applied.

The ergonomic design allows easy adjustment of control elements. With only 1/4 of a turn from open to close, the fan control allows minimal effort, and the trigger design, with less trigger pull, means the painter experience fatigue-free work. The control adjustments and gun body have a high-gloss chrome finish for corrosion protection. Moreover, the material passages have a special coating to enhance internal corrosion protection making the SATAjet 4000 B suitable for waterborne or solvent base material.

SATAjet 4000 B RP

Technical Data

Inlet pressure: 29-32 psi
 Compliant: max. 32 psi
 Air consumption: 10.4 cfm at 29 psi
 Spray distance Field of application: 6.5-8.5" / 17-21 cm



Nozzle Size	1.0	1.1	1.2	1.2W	1.3	1.4	1.6	1.8	2.0	2.5
-------------	-----	-----	-----	------	-----	-----	-----	-----	-----	-----

Standard with RPS disposable cup 0.3 l / 0.6 l / 0.9 l (each 1x) without swivel joint

Part No.	176974	171520	169979	169987	169995	170001	176990	177014	177030	177055
----------	--------	--------	--------	--------	--------	--------	--------	--------	--------	--------

DIGITAL with RPS disposable cup 0.3 l / 0.6 l / 0.9 l (each 1x) without swivel joint

Part No.	176982	171553	170019	170027	170035	170050	177006	177022	177048	177063
----------	--------	--------	--------	--------	--------	--------	--------	--------	--------	--------

Nozzle Set	1.0	1.1	1.2	1.2W	1.3	1.4	1.6	1.8	2.0	2.5
------------	-----	-----	-----	------	-----	-----	-----	-----	-----	-----

Part No.	166991	167007	167015	167023	167049	167056	167072	167080	168625	168633
----------	--------	--------	--------	--------	--------	--------	--------	--------	--------	--------

SATAjet 4000 B HVLP

Technical Data

Inlet pressure: 29 psi
 HVLP: max. 29 psi
 Air consumption at 15.2 cfm at 29 psi
 Spray distance Field of application: 4-6" / 10-15 cm

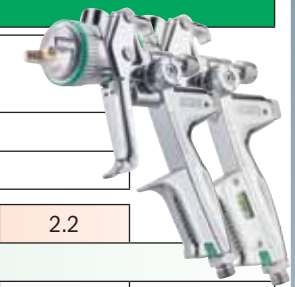

Nozzle Size	1.0	1.2	WSB	1.3	1.4	1.4 HC	1.5	1.7	1.9	2.2
-------------	-----	-----	-----	-----	-----	--------	-----	-----	-----	-----

Standard with RPS disposable cup 0.3 l / 0.6 l / 0.9 l (each 1x) without swivel joint

Part No.	176891	170159	170167	170175	170209	170217	170696	176917	176941	176958
----------	--------	--------	--------	--------	--------	--------	--------	--------	--------	--------

DIGITAL with RPS disposable cup 0.3 l / 0.6 l / 0.9 l (each 1x) without swivel joint

Part No.	176909	166249	170357	170365	170399	170407	170704	176925	176933	176966
----------	--------	--------	--------	--------	--------	--------	--------	--------	--------	--------

Nozzle Set	1.0	1.2	WSB	1.3	1.4	1.4 HC	1.5	1.7	1.9	2.2
------------	-----	-----	-----	-----	-----	--------	-----	-----	-----	-----

Part No.	166926	166934	166983	166942	166967	171512	166975	168658	168666	168674
----------	--------	--------	--------	--------	--------	--------	--------	--------	--------	--------

Test Air Cap *	171355			171348				Call		
----------------	--------	--	--	--------	--	--	--	------	--	--

Nozzle Size	1.3C	1.3LV
-------------	------	-------

Standard with RPS disposable cup 0.3 l / 0.6 l / 0.9 l (each 1x) without swivel joint

Part No.	170183	170191
----------	--------	--------

DIGITAL with RPS disposable cup 0.3 l / 0.6 l / 0.9 l (each 1x) without swivel joint

Part No.	170373	170381
----------	--------	--------

Nozzle Set	1.3C	1.3LV
------------	------	-------

Part No.	166959	168641
----------	--------	--------

Test Air Cap *	171348	171355
----------------	--------	--------

* Test Air Caps are special order items only

Spare Parts SATAjet® 4000 B

Part No./Descr.	
240	Packing, air piston (repair centre only)
1818	Circlip for air cap
3426	Circlip, for trigger sleeve (repair centre only)
3970	Seal, air micrometer
10520	12-pk spring (single unit #17897)
14605	Bushing, needle packing (repair centre only)
14993	Spring, needle packing (repair centre only)
15438	Paint needle packing set
17152	12-pk spring (single unit #27813)
17897	Spring, paint needle (repair centre only)
19745	Swivel fitting, non-digital guns 1/4" air inlet
23275	Packing, needle (repair centre only)
27813	Spring, air piston (repair centre only)
54775	Pad, rubber trigger, pk of 5
69872	O ring, fan control (repair centre only)
82552	Kit, air piston service
86843	Piston, air rod
96875	Seal, inner cup
133934	O ring, fan control, pk of 3
133942	Bushing, air piston
133959	Kit, spring, pk of 3 each of #27813 & #17897
133967	Pin, air micrometer, pk of 3
133991	Packing, air piston, pk of 3
134098	Fitting, standard 1/4" air inlet, non-digital
140582	Seal, Fluid Tip, pk of 5
164574	Screw, fan control (repair centre only)
164623	Pin, upper trigger (repair centre only)
164624	Pin, lower trigger (repair centre only)
165928	CCS clips, pk of 4
165944	Control Spindle, w/O ring
165951	Air distribution ring, pk of 3 with tool
165977	Trigger kit
165985	Seal retainer complete w/ sleeve
165993	Battery Kit w/cover and seal
166009	Kit, trigger sleeve
166017	Air micrometer (air flow control)
166025	Material flow control w/counter nut
166033	Knob, fan control w/screw
166116	Air inlet fitting, w/o swivel for Digital guns
166330	Trigger only
166355	Cover plate for dig display (repair centre only)
166371	Air cap ring w/ seal only, RP blue
166389	Air cap ring w/ seal only, HVL green
167882	Washer, tension spring (repair centre only)
172429	Seal, air cap ring, pk of 5
203422	Swivel joint for Digital Guns

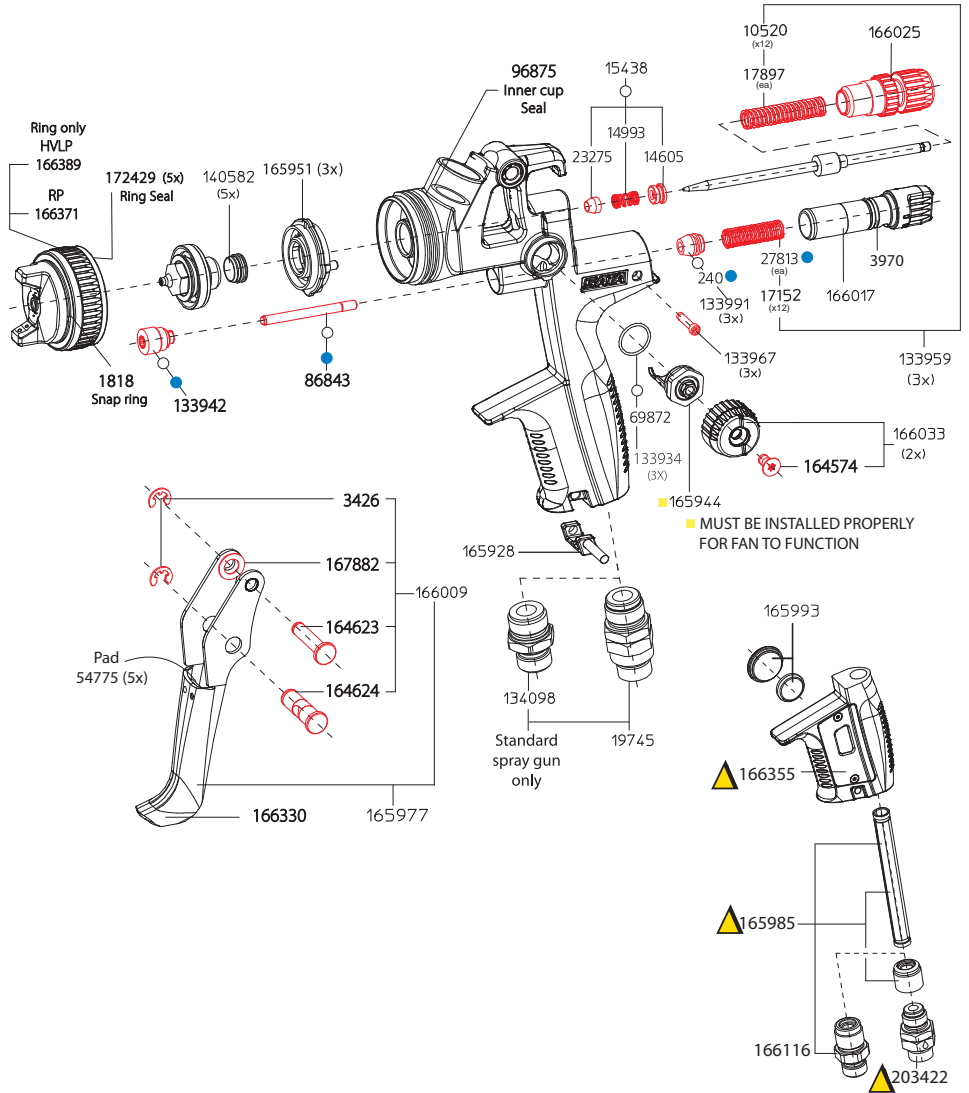

Part No./Descr.
165936
Tool kit
· Universal spanner
· Cleaning brush
· 198598 Combi tool
· Paint strainer
· Extraction tool
· CCS Clip

Part No./Descr.
166058
Repair kit
82552
Air piston service set
136960
Sealing kit

SATA adam 2

Part No./Descr.
160853
SATA adam 2 (psi)
160788
SATA adam 2 dock

WARNING
 Removing the DIGITAL air inlet tube or the DIGITAL display cover VOIDS WARRANTY
 Damaged DIGITAL gauges must be returned for service to ensure proper functionality

Technical modifications and printing errors reserved



SATaminijet® 4400 B HVLP / RP®

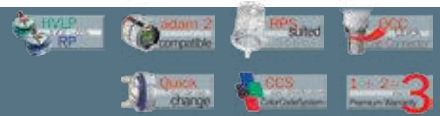

SATaminijet 4400 B RP / RP SR

Technical Data	Inlet pressure: 7-36 psi
	Air consumption at 7 cfm @ 36 psi
	Spray distance: 4.7-7.5" / 12-19 cm



Nozzle Size	0.5	1.4	1.6	0.8 SR	1.0 SR	1.2 SR
--------------------	-----	-----	-----	--------	--------	--------

Standard / Spot Repair with RPS disposable cup 0.3 l (2x)

Part No.	202382	198374	204156	202390	198358	198366
-----------------	--------	--------	--------	--------	--------	--------

Nozzle Set	0.5	1.4	1.6	0.8 SR	1.0 SR	1.2 SR
-------------------	-----	-----	-----	--------	--------	--------

Part No.	202408	201319	201327	201285	201293	201301
-----------------	--------	--------	--------	--------	--------	--------

Test Air Cap	206466	206482	206474
---------------------	--------	--------	--------

SATaminijet 4400 B HVLP / HVLP SR

Technical Data	Inlet pressure: 7-29 psi
	Air consumption at 4.2 cfm @ 29 psi
	Spray distance: 5-6" / 12-15 cm



Nozzle Size	0.3	0.5	0.8	1.0	1.1	0.8 SR	1.0 SR	1.2 SR	1.4 SR
--------------------	-----	-----	-----	-----	-----	--------	--------	--------	--------

Standard / Spot Repair supplied with RPS disposable cup 0.3 l (2x)

Part No.	204164	204172	204180	204198	204206	198168	198176	198184	198192
-----------------	--------	--------	--------	--------	--------	--------	--------	--------	--------

Nozzle Set	0.3	0.5	0.8	1.0	1.1	0.8 SR	1.0 SR	1.2 SR	1.4 SR
-------------------	-----	-----	-----	-----	-----	--------	--------	--------	--------

Part No.	201194	201202	201210	201228	201236	201244	201251	201269	201277
-----------------	--------	--------	--------	--------	--------	--------	--------	--------	--------

Test Air Cap	206417	206425	206433	206411	206458
---------------------	--------	--------	--------	--------	--------



198382 | SATA design set with SATaminijet 4400 B HVLP nozzle 1.0

Reusable QCC PVC and aluminum cups sold separately

Test air caps and design set are special order items, and are considered non-returnable

Spray fan comparison



SATaminijet 4400 B HVLP SATaminijet 4400 B RP for standard applications		SATaminijet 4400 B HVLP SR SATaminijet 4400 B RP SR especially for spot repair applications:	
1.1 HVLP (at 29 psi) Spray distance 6"/15 cm	1.6 RP (at 36 psi) Spray distance 6.7"/17 cm	1.2 HVLP SR (at 29 psi) Spray distance 6 in	1.2 RP SR (at 36 psi) Spray distance 6.7 in
 Wet core 6.1"/15.5 cm	 Wet core 6.9-7.3"/17.5-18.5 cm	 Wet core 7.7"/19.5 cm	 Wet core 8.3-8.7"/21-22 cm

Spare parts SATAminijet® 4400 B

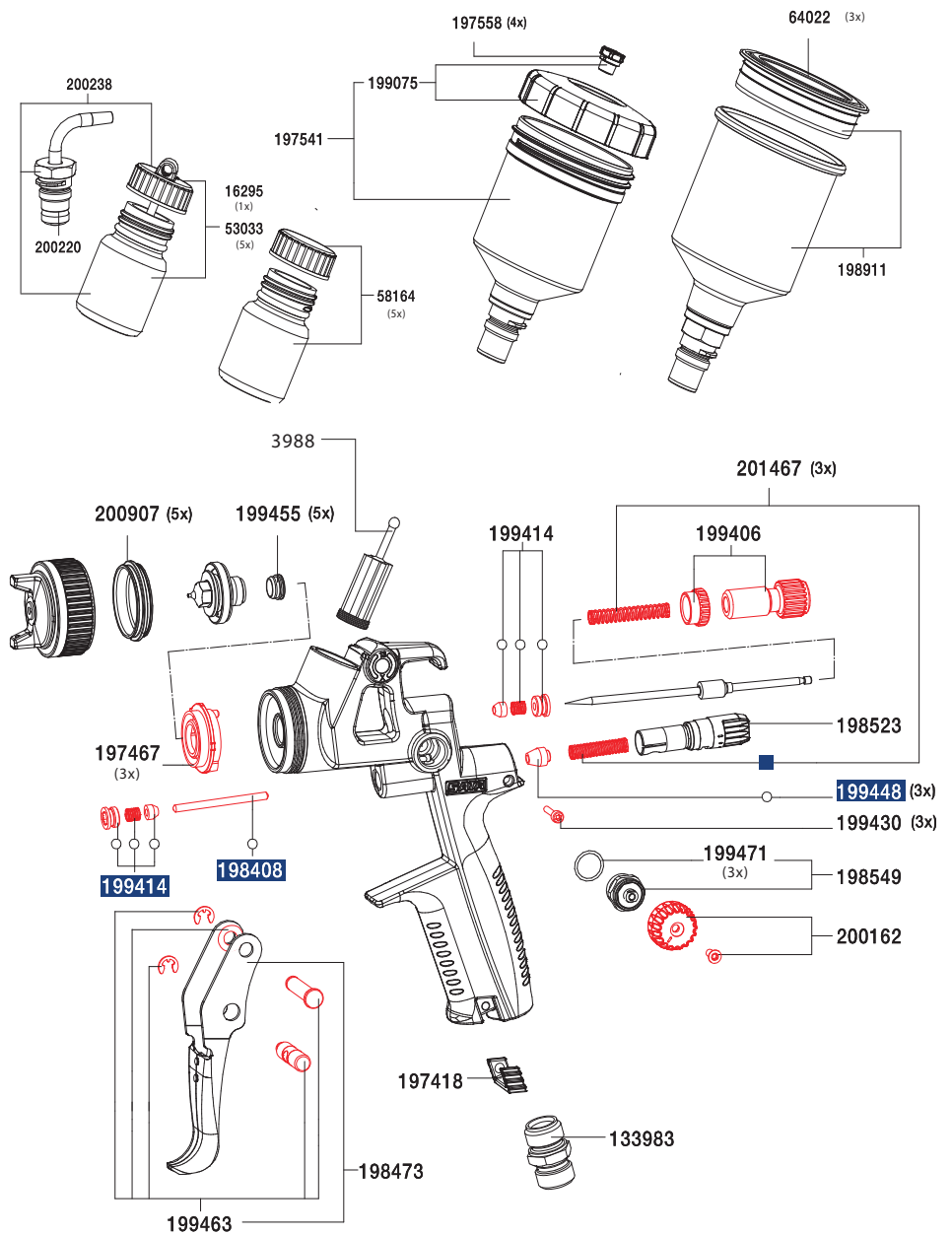
Part No./Descr.	
3988	Strainer, 300 µm (10x)
16295	25 ml glass cup with plug-in cup
53033	25 ml glass cup with plug-in cup (5x)
58164	25 ml glass cup with blind lid (5x)
64022	PVC lid (3x)
133983	Air connection piece G1/4 male thread
197418	CCS Clips, green, blue, red, black (4x)
197467	Air distribution ring (3x), w/puller
197541	0.125 l QCC reusable plastic cup, cpl
197558	Anti-drip device (4x)
198408	Air piston rod
198473	Trigger kit
198523	Air micrometer
198549	Spindle for round/flat spray control
198911	0.15 l QCC aluminum cup
199075	Screw cap with drip catcher ring and anti-drip device
199406	Material flow control with counter nut
199414	Packing for paint needle and air piston rod
199430	Adjustment screw (3x) for air micrometer
199448	Air piston head (3x)
199455	Sealing element (5x) for fluid tip
199463	Trigger sleeve kit
199471	Gasket (3x) for spindle
201467	Pressure spring (each 3x) for paint needle and air piston
200162	Control knob with screw each 2)
200220	Plug-in cup connection with QCC
200238	25 ml glass cup with plug-in lid (5x) and QCC plug-in connection (1x)
200907	Sealing ring (5x)



SATA adam 2 mini

Part No./Descr.	
160887 SATA adam 2 mini (psi)	
160861 SATA adam 2 dock for minijets	

Part No./Descr.
198614 Repair kit
<input type="checkbox"/> 199422 Air piston service unit
<input type="radio"/> 200246 Sealing kit

Part No./Descr.
198572 Tool kit
<ul style="list-style-type: none"> • Universal spanner • Cleaning brush • 198598 Combi tool • Paint strainer • Extraction tool • CCS-Clip Kit

Technical modifications and printing errors reserved



SATAjet® 3000 K RP®/HVLP



Use for high quality topcoat finishes in automotive, fleet or any industrial application. The SATAjet® 3000 K™ HVLP offers the finest atomization and a top-class finish and achieved by SATA® technology, ensures transfer efficiencies considerably above 65 % required by VOC legislation. The patented air circulation principle provides an especially homogeneous and soft fan. The large fan and high material flow rates ensure swift work. Excellent ergonomics - the short gun body, extremely low weight and the optimum balance ensure the gun "fits like a glove". Suitable for water-borne materials - paint needle and nozzle are made of stainless steel, and the nickel-plated gun body has been refined with a special coating. The durable air caps are made of brass (not of aluminium), therefore ensuring a long life time - a factor particularly important for industrial use.

SATAjet 3000 K RP						
Technical Data		Inlet pressure: 36-43 psi				
		Air consumption: 15.2 cfm at 36 psi				
		Spray distance: 6-9" / 17-21 cm				
		Material connection: G 3/8 male thread				
Nozzle Size	0.8	1.1	1.3	1.5	1.7	2.0
Standard gun Standard (STD) or Specially Treated (ST) Nozzle						
Part No. STD	92932	93336	93344	93351	93369	93377
Part No. ST	163022	141994	142265	166421	93369ST	-
Nozzle Set	0.8	1.1	1.3	1.5	1.7	2.0
Part No. STD	92494	92502	92510	92528	95422	95356
Part No. ST	141317	137901	137919	137927	137935	137943



SATAjet 3000 K HVLP						
Technical Data		Inlet pressure: 36 psi				
		Air consumption: 18.7 cfm at 36 psi				
		Spray distance: 4-6" / 10-15 cm				
		Material connection: G 3/8 male thread				
Nozzle Size	0.8	1.0	1.2	1.4	1.6	2.0
Standard gun with Standard (STD) or Specially Treated (ST) Nozzle						
Part No. STD	93385	92924	93393	193656	96164	96172
Part No. ST	93385ST	92924ST	93393ST	-	137851	96172ST
Test Air Cap	95059		95067			
Nozzle Set	0.8	1.0	1.2	1.4	1.6	2.0
Part No. STD	92783	92791	92809	191379	92817	92825
Part No. ST	147058	137950	137968	-	137976	137984
Part No. HM	-	-	-	-	59626	61408



HM = Carbide (hard metal)

Accessories for SATA pressure fed spray guns	
92031	Paint pipe for SATA pressure fed spray guns G3/8i - G3/8a version for waterborne materials
38265	Strainer for SATA pressure fed spray guns G3/8i - G3/8a, 60 mesh, WA version

For additional accessories see page 58

Spare Parts SATAjet® 3000 K

Part No./Descr.	
240	Air piston packing
1503	Fan Control screw
3426	Circlip
3624	Pin, micrometer (sold w/ repairs only)
3699	Pin, lower trigger
7757	Color code discs, 4-pk
10033	Air cap ring with seal, Blue, RP
10520	12-pk spring (single unit #17897)
12591	Pin, upper trigger
14605	Bushing, needle packing (sold w/ repairs only)
14993	Spring, needle packing (sold w/ repairs only)
15438	Needle packing service set
17152	12-pk spring (single unit #27813)
17525	Trigger washer
17897	Spring, paint needle (sold w/ repairs only)
23275	Needle Packing (sold w/ repairs only)
27813	Spring, air piston (sold w/ repairs only)
38268	Material Filter, (sold separately)
38638	Air distribution ring, single (sold w/ repairs only)
50542	Lock nut, fluid control
54775	Trigger pad, pack of 5
91108	Replacement QC Nipple for #91140 & 91157 (sold separately from gun)
91140	Material coupling w/ plug in nipple (sold separately from gun)
91157	Material coupling w/ plug in nipple and sieve (sold separately from gun)
91835	Knob, fan control
91884	Trigger
91959	Piston rod
92031	Paint pipe (sold separately from gun)
92049	Fan control
92056	Trigger service set
92619	Fluid control and lock nut
92742	Fan control service set
93526	S/S Material connection - (sold w/ repairs only, see warning)
93559	S/S Insert - (sold w/ repairs only, see warning)
93732	Air cap ring with seal, HVLP Green
97824	Air distribution ring, 3-pk w. tool
133926	Trigger sleeve kit
133959	Kit, spring, pk of 3 each of #27813 & #17897
139964	Air micrometer
133967	Pin, for air micrometer, 3-pk
133991	Packing, air piston, 3-pk
134098	Air inlet fitting, 1/4" BSP
143834	Air cap ring seal, 5-pk

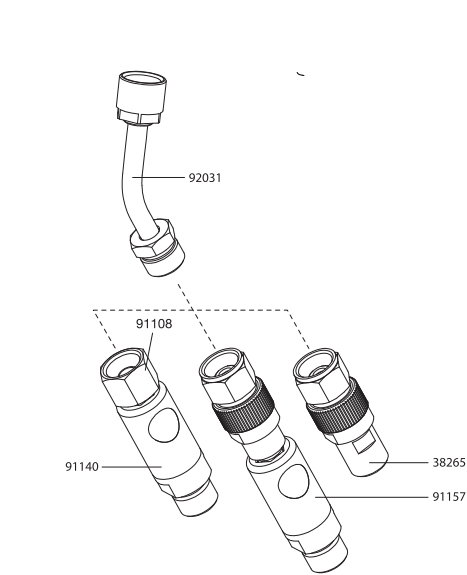
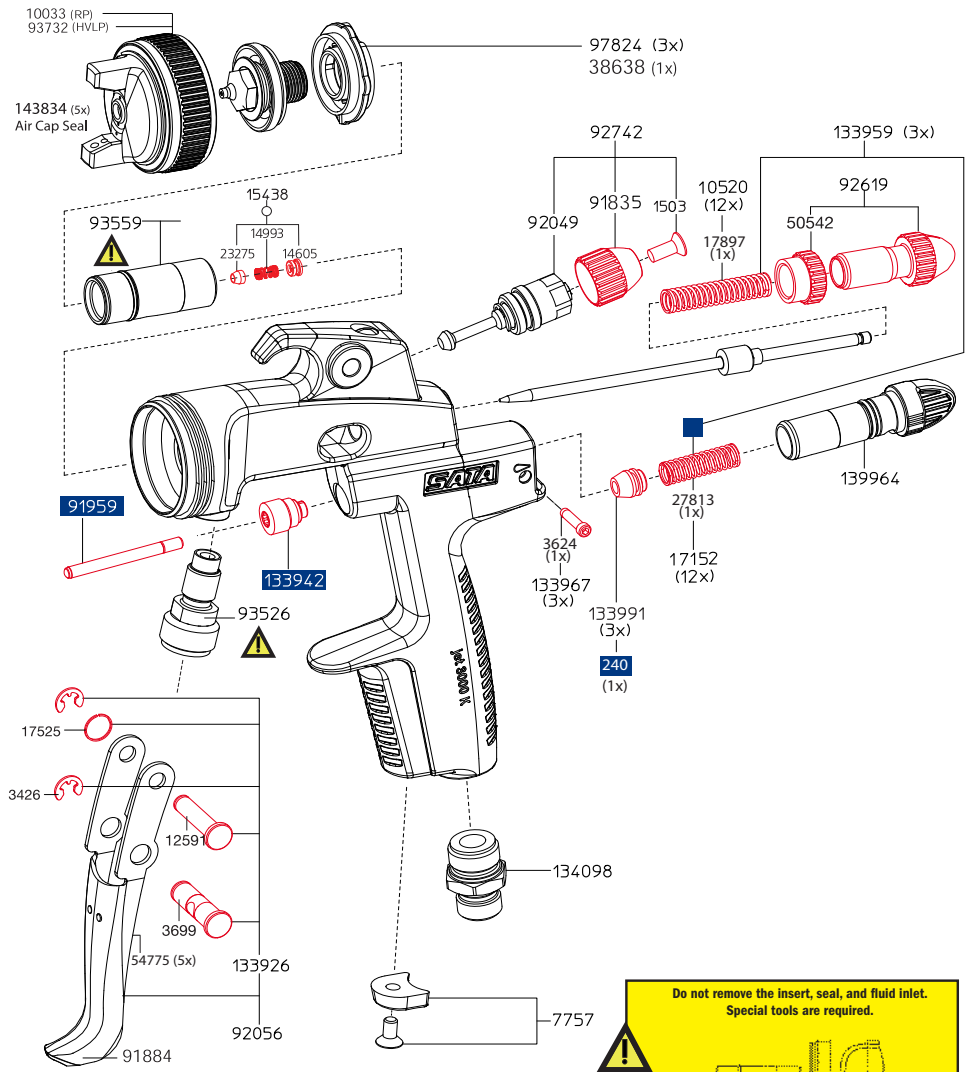



Do not remove the insert, seal, and fluid inlet. Special tools are required.

CALL SATA repair department for details.

Part No./Descr.
92577
Tool kit
· Universal spanner
· Cleaning brush
· 2 x allen wrench: 2mm & 4mm
· Torx wrench T20
· Extraction tool
· Paint sieve

Part No./Descr.
92767
Repair kit
○ 92759
Air piston service set

SATA adam 2

Part No./Descr.		
160853	SATA adam 2 (psi)	
160788	SATA adam 2 dock	

Technical modifications and printing errors reserved



SATAjet® 3000 K spray mix

The particular advantage of this gun is the adjustment possibilities making it comparable to a classic air-atomizing paint spray gun. The spray fan width may be adapted perfectly to the object. Large surface covering capacity, while emitting low overspray and helping to protect the environment makes this ideal for spraying large quantities of high viscosity material for high quality surface finishes. Fully suitable for waterborne materials, the large nozzle range for perfect adaptation to material and object. Special emphasis is put on what the item is used for such as truck frames, locomotives, containers and ships.

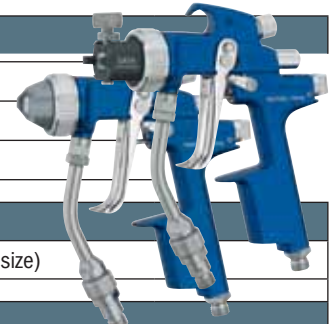

SATAjet 3000 K spray mix

Technical Data	Max. operating pressure atomization air: 145 psi
	Max. operating pressure material: 3,625 psi
	Weight incl. material filter: 23 oz.

Spray mix gun

120006	SATAjet 3000 K spray with paint pipe, strainer 100 mesh, and nozzle set (specify material nozzle size)
--------	--

Spray mix gun w/ Reversing switch

120014	SATAjet 3000 K spray with paint pipe, strainer 100 mesh, and reversing nozzle (specify reversing nozzle size)
120279	Reversing switch kit for SATAjet 3000 K spray mix w/out reversing nozzle - one time purchase, mandatory for use of reversing nozzle

Nozzles - SATAjet 3000 K spray mix

Fluid tip

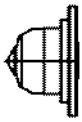

Reversing nozzle for reversing switch

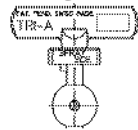

Technical Data

Nozzle No.	Part No.	Nozzle No.	Part No.	ø mm	ø inch	Angle	Fan Width In.	oz/min @ 1015 psi	Strainer	
1840	23044*			0.18	0.007	40°	7	5.41		
2325	7328			0.23	0.009	25°	6	7.78	200 msh 85 µm	74856 4 per set
2350	7435			0.23	0.009	50°	9	7.78		
2360	74922			0.23	0.009	60°	10	7.78		
		2550	120220	0.25	0.010	20°/50°	4/9	8.45		
2825	16998			0.28	0.011	25°	6	10.14		
2850	50906			0.28	0.011	50°	9	10.14		
2865	13771			0.28	0.011	65°	10	10.14		
		3050	120238	0.30	0.012	20°/50°	4/9	12.85	100 msh 150 µm	12278 4 per set
3325	20206			0.33	0.013	25°	6	15.22		
3350	50898			0.33	0.013	50°	9	15.22		
3365	13789			0.33	0.013	65°	11	15.22		
3375	74930			0.33	0.013	75°	13	15.22		
3390	73742			0.33	0.013	90°	16	15.22		
		3550	120246	0.35	0.014	20°/50°	4/9	17		
3825	13797			0.38	0.015	25°	6	20.63	60 msh 250 µm	12260 4 per set
3850	7344			0.38	0.015	50°	10	20.63		
3882	74948			0.38	0.015	82°	14	20.63		
		4050	120253	0.40	0.016	20°/50°	4/9	23.6		
4650	19307			0.46	0.018	50°	9	32		
4682	74955			0.46	0.018	82°	14	32		
5370	150276			0.53	0.021	70°	13	42		
6050	17004			0.60	0.024	50°	12	53.76		

For additional accessories see page 58

Spare Parts SATAjet® 3000 K spray mix

Part No./Descr.	
240	Air piston packing
1503	Fan Control screw
3426	Circlip
3699	Pin, lower trigger
12260	Sieve, 60 msh, pkg of 4
12278	Sieve, 100 msh, pkg of 4
12591	Upper trigger pin
17525	Trigger washer
18341	Needle spring
27813	Spring, air piston (sold w/ repairs only)
74856	Sieve, 200 msh, 4-pk
91959	Piston rod
97824	Air distribution ring, 3-pk w. tool
98418	Material control knob
98434	Pre-Nozzle
98442	Seal ring, pre-nozzle
98459	Air cap, round/flat
98525	Packing holder
98541	Needle tip
98590	S/S Material connection - (sold w/ repairs only, see warning)
98608	Paint pipe, ?, w/100 msh filter
98665	Air cap ring
98681	Trigger service set
98764	Pre-nozzle w/needle tip
98772	Needle w/needle tip
98806	Fan control service set
120071	Trigger lock, complete
120261	Seal, reversing nozzle
120279	Reversing switch
133926	Trigger sleeve kit
133942	Air piston packing
133967	Pin, for air micrometer, 3-pk
133991	Packing, air piston, 3-pk
134098	Air inlet fitting, 1/4" BSP
139964	Air Micrometer

Part No./Descr.

98699

Tool kit

- Universal spanner
- Wrench
- Allen wrench: 2mm & 4mm
- Socket Set
- Extraction tool

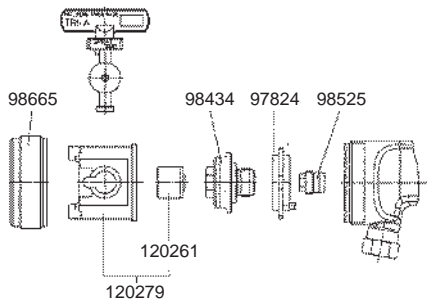
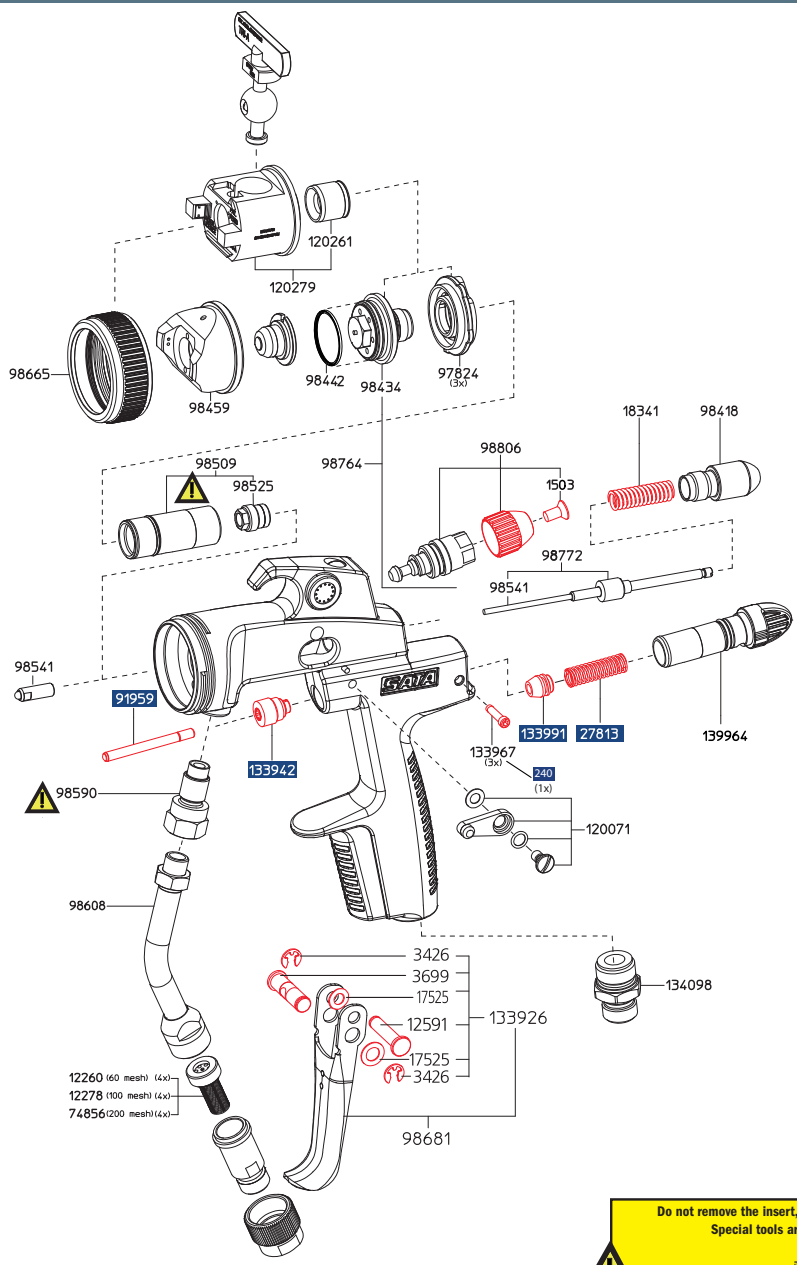
Do not remove the insert, seal, and fluid inlet. Special tools are required.

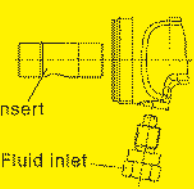

CALL SATA repair department for details.

Part No./Descr.
98707
Repair kit
<input type="radio"/> 92759
<input type="radio"/> Air piston service set
<input type="radio"/> 30833
<input type="radio"/> Nozzle cleaning kit

Technical modifications and printing errors reserved



SATAjet® 1000 B RP®/HVLP

SATAjet® 1000 B RP®/HVLP LIGNUM



SATAjet 1000 B RP

Technical Data	Inlet pressure: 21-29 psi
	Air consumption: 7.1 cfm at 29 psi
	Spray distance: 6.5-8.5" / 17-21 cm

Nozzle Size	0.8	1.0	1.3	1.6	1.8	2.0	2.5	3.0	4.0	5.0
--------------------	-----	-----	-----	-----	-----	-----	-----	-----	-----	-----

Anodised silver spray gun with QCC 0.6 | PVC cup

Part No.	151183	151191	149302	149310	150391	149328	151209	151217	154161	-
-----------------	--------	--------	--------	--------	--------	--------	--------	--------	--------	---

Anodised silver spray gun with QCC 0.75 | aluminum cup

Part No.	151225	151233	150342	149344	150409	149351	151241	151258	154179	-
-----------------	--------	--------	--------	--------	--------	--------	--------	--------	--------	---

Anodised silver Spray gun with QCC 1.0 | aluminum cup

Part No.	-	158071	158089	158097	158105	158113	158121	158139	-	-
-----------------	---	--------	--------	--------	--------	--------	--------	--------	---	---

Lignum spray gun with QCC 0.75 | aluminum cup

Part No.	-	-	193581	193599	193607	193615	-	-	-	-
-----------------	---	---	--------	--------	--------	--------	---	---	---	---

Nozzle Set	0.8	1.0	1.3	1.6	1.8	2.0	2.5	3.0	4.0	5.0
-------------------	-----	-----	-----	-----	-----	-----	-----	-----	-----	-----

Part No.	151316	151324	149161	149179	150417	149187	151332	151340	154187	154195
-----------------	--------	--------	--------	--------	--------	--------	--------	--------	--------	--------

RP nozzle extensions available - see page 60 & 61

SATAjet 1000 RP B D (drill) and OS (without control bores)

Modified nozzle set for special glue applications, in particular water-dispersion adhesives. Not suitable for paint application

Nozzle Size	1.6 OS	1.6 D
--------------------	--------	-------

Gun Part No.	199497	164896	* Special order Item
---------------------	--------	--------	----------------------

Nozzle Set	199505	164970	* Special order Item
-------------------	--------	--------	----------------------

SATAjet 1000 B HVLP

Technical Data	Inlet pressure: 2.0 bar / 29 psi
	Air consumption: 12.5 cfm at 29 psi
	Spray distance: 5-6.5" / 13-17 cm

Nozzle Size	1.4	1.7	1.9	2.1
--------------------	-----	-----	-----	-----

Anodised silver spray gun with QCC 0.6 | PVC cup

Part No.	149377	149385	149393	149401
-----------------	--------	--------	--------	--------

Anodised silver spray gun with QCC 0.75 | aluminum cup

Part No.	149419	149427	149435	149443
-----------------	--------	--------	--------	--------

Anodised silver spray gun with QCC 1.0 | aluminum cup

Part No.	158147	158154	Call	Call
-----------------	--------	--------	------	------

Lignum spray gun with QCC 1.0 | aluminum cup

Part No.	193623	193631	193649	-
-----------------	--------	--------	--------	---

Test Air Cap	157222			
---------------------	--------	--	--	--

Nozzle Set	1.4	1.7	1.9	2.1
-------------------	-----	-----	-----	-----

Part No.	149195	149203	149211	149229
-----------------	--------	--------	--------	--------

SATAjet® 1000 B RP®/HVLP SATAjet® 1000 B RP®/HVLP LIGNUM

Part No./Descr.	
240	Seal, air piston (repair centre only)
1503	Screw, fan control
3426	Circlip, pin
3624	Pin, air micrometer (repair centre only)
3699	Pin, lower trigger
3970	Teflon seal for air micrometer
6395	Disc, CC (standard), pk of 4
10520	12-pk spring (single unit #17897)
12591	Pin, upper trigger
14605	Bushing, needle
14993	Spring, needle bushing
15438	Kit, needle packing
17152	12-pk spring (single unit #27813)
17525	Washer, tension spring
17897	Spring, needle
23275	Seal, needle
27813	Spring, air piston
69872	O-ring, fan control
89771	Fan control spindle, RH w/O-ring
91959	Air piston rod
96875	Seal, inner cup
130393	Seal, air cap ring
130435	Air cap ring only (RP)
130443	Air cap ring only (HVLP)
130492	Trigger kit
133926	Kit, trigger sleeve
133934	O-ring, fan control, pk of 3
133942	Bushing, air piston
133959	Spring kit, 3 each of #27813 & #17897
133967	Pin, air micrometer, pk of 3
133983	Fitting, air inlet, R 1/4"
133991	Seal, air piston, pk of 3
134031	Knob, fan control w/screw, 2 pk
139188	Kit, fluid control and lock nut
139964	Air micrometer, standard
140574	Knob, fan control w/screw
140582	Seal, fluid tip, pk of 5
143230	Air distribution ring, pk of 3

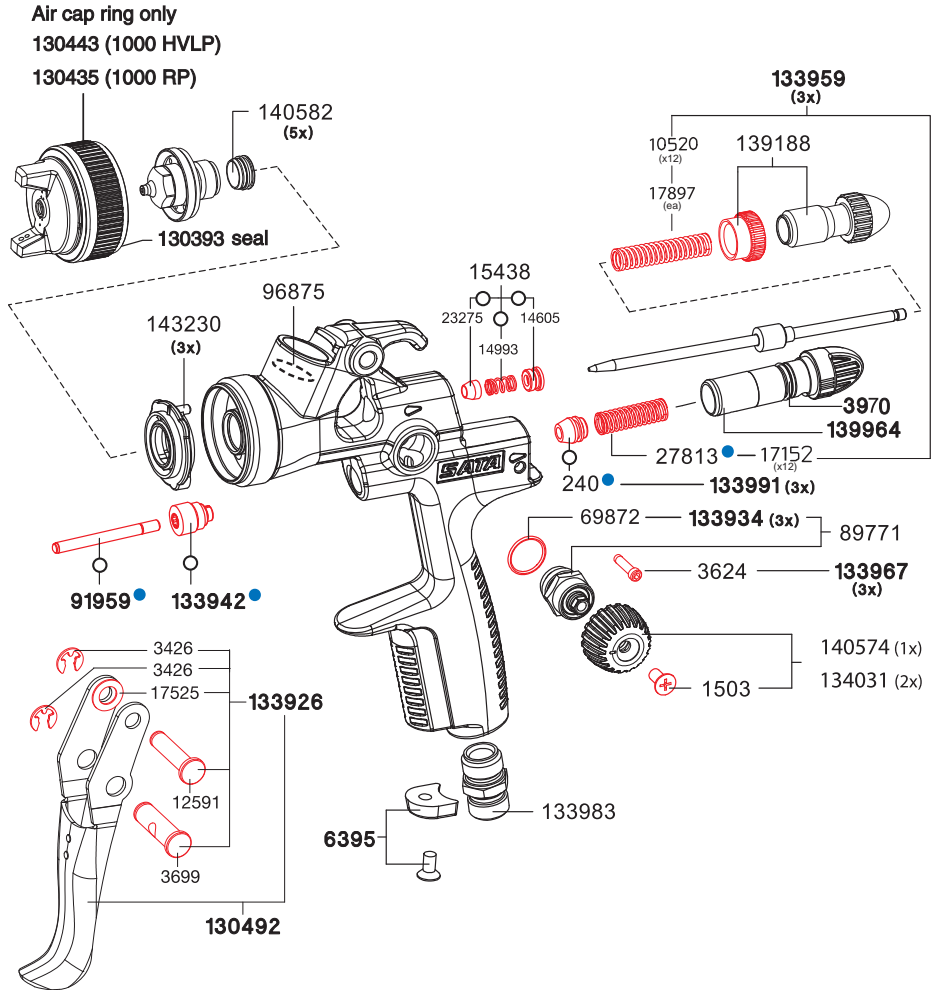

SATA adam 2

Part No./Descr.	
160853 SATA adam 2 (psi)	
160788 SATA adam 2 dock	

Part No./Descr.	
9050 Tool kit	
<ul style="list-style-type: none"> • Universal spanner • Cleaning brush • Allen/Trox wrench • Allen wrench • Extraction tool 	

Part No./Descr.
130542 Repair kit
92759 Air piston service set
183780 Sealing Kit

SATAjet® 1000 K RP®/HVLP



The small and lightweight SATAjet 1000 K spray gun is suitable for use with pressure pots, double diaphragm pumps, and air assist airless pumps. Due to its large range of available nozzle sizes, this pressure fed spray gun is perfectly suitable for the applications of various materials from thin wood stains, clear coats, textured paint and glaze to glue and other thixotropic materials. Extensions are available in various versions and sizes allow perfect coating of areas with difficult access.



SATAjet 1000 K RP										
Technical Data		Inlet pressure: 36 psi								
		Air consumption: 14.5 cfm at 36 psi								
		Spray distance: 6.5-8.5" / 17-21 cm								
		Material connection: G 3/8 exterior thread								
Nozzle Size	0.8	1.1	1.3	1.5	1.7	2.0	2.5	3.0	4.0	5.0
Standard gun with Standard (STD) or Specially Treated (ST) Nozzle										
Part No. STD	132092	132100	132118	132126	132134	132142	153486	153494	154336	-
Part No. ST	141903	141911	141929	141937	141945	141952	-	-	-	-
Nozzle Set	0.8	1.1	1.3	1.5	1.7	2.0	2.5	3.0	4.0	5.0
Part No. STD	132159	132167	132175	132183	132191	132209	153528	153536	154377	154385
Part No. ST	141648	141655	141663	141689	141697	141705	159442	-	-	-



RP nozzle extensions available - see page 60 & 61

SATAjet 1000 K HVLP										
Technical Data		Inlet pressure: 36 psi								
		Air consumption: 18.7 cfm at 36 psi								
		Spray distance: 4-6" / 10-15 cm								
		Material connection: G 3/8 exterior thread								
Nozzle	0.8	1.0	1.2	1.4	1.6	2.0				
Standard gun with Standard (STD) or Specially Treated (ST) Nozzle										
Part No. STD	139196	139204	139212	193664	139220	139238				
Part No. ST	141960	141978	141986	-	142000	142018	ST = Special treated nozzle resistant to abrasive material			
Test Air Cap	143891		143909							
Nozzle Set	0.8	1.0	1.2	1.4	1.6	2.0				
Part No. STD	139253	139261	139279	191387	139287	139295				
Part No. ST	141762	141770	141804	-	141812	141838				



Accessories for SATA pressure fed spray guns		
92031	Paint pipe for SATA pressure fed spray guns G3/8i - G3/8a version for waterborne materials	
38265	Strainer for SATA pressure fed spray guns G3/8i - G3/8a, 60 mesh, WA version	

Spare Parts SATAjet® 1000 K

Part No./Descr.	
240	Seal, air piston (repair centre only)
1503	Screw, fan control
3426	Circlip, pin
3624	Pin, air micrometer (repair centre only)
3699	Pin, lower trigger
3970	Teflon seal for air micrometer
6395	Disc, CC (standard), pk of 4
10520	Spring, needle, 12-pk of #17897
12591	Pin, upper trigger
14605	Bushing, needle
14993	Spring, needle bushing
15438	Kit, needle packing
17152	Spring, air piston, 12-pk of #27812
17525	Washer, tension spring
17897	Spring, needle (repair centre only)
23275	Seal, needle
27813	Spring, air piston (repair centre only)
69872	O-ring, fan control, (repair centre only)
89771	Fan control spindle, RH w/O-ring
91959	Air piston
93526	Material Connection
130393	Seal, air cap ring
130435	Air cap ring only (RP)
130443	Air cap ring only (HVLP)
130484	Insert w/ needle packing kit
130492	Trigger kit
130534	Air distribution ring 3-pk
133926	Kit, trigger sleeve
133934	O-ring, fan control, pk of 3
133942	Bushing, air piston
133959	Spring kit, 3 each of #27813 & #17897
133967	Pin, air micrometer, pk of 3
133983	Air connection piece 1/4" male thread
133991	Seal, air piston, pk of 3
139188	Kit, fluid control and lock nut
139964	Air micrometer, standard
140574	Knob, fan control w/screw
140582	Seal, fluid tip, pk of 5

SATA adam 2

Part No./Descr.	
160853	SATA adam 2 (psi)
160788	SATA adam 2 dock

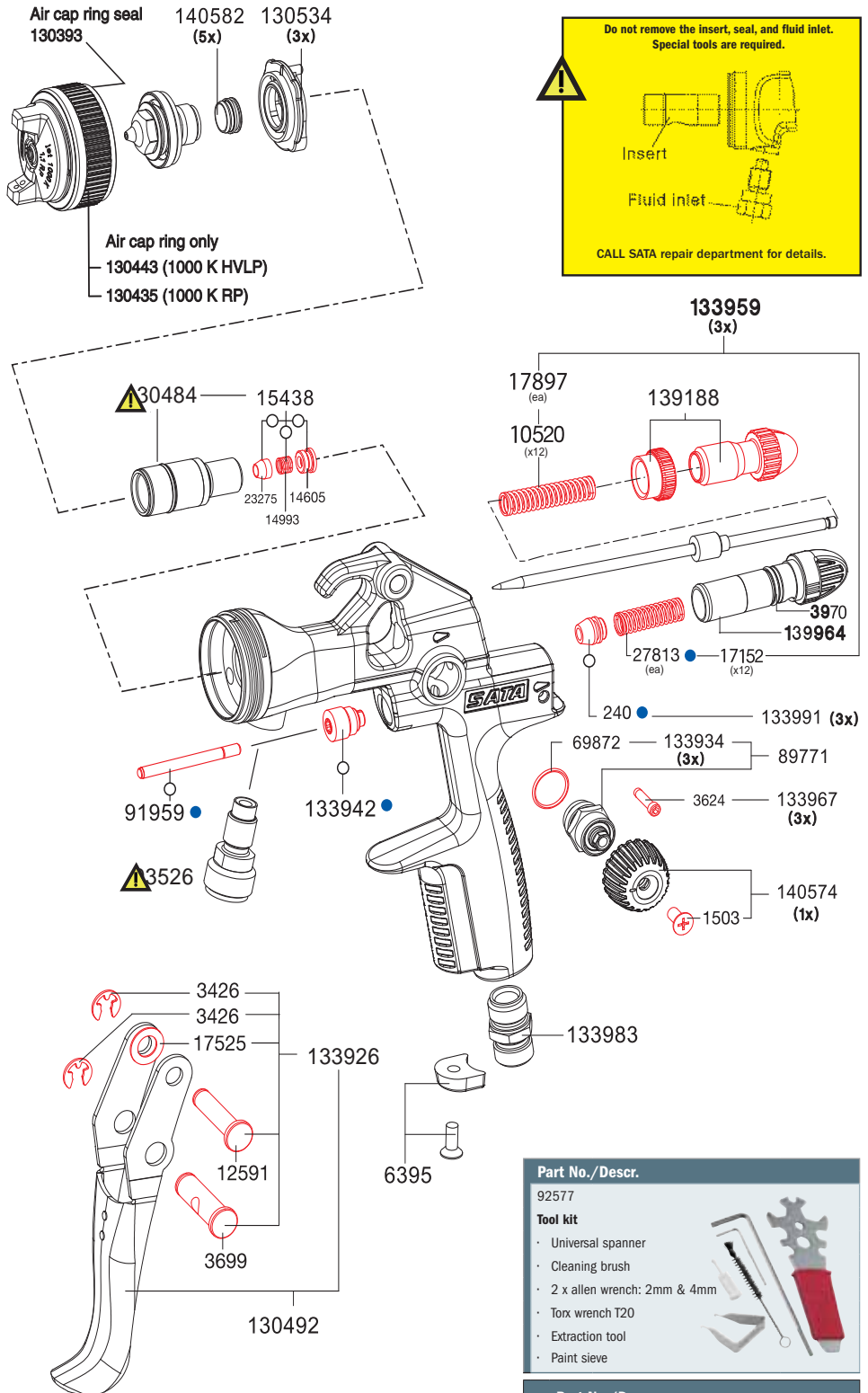

Part No./Descr.
92577
Tool kit
• Universal spanner
• Cleaning brush
• 2 x allen wrench: 2mm & 4mm
• Tox wrench T20
• Extraction tool
• Paint sieve

Part No./Descr.
130542
Repair kit
○ 92759
Air piston service set

Technical modifications and printing errors reserved

For additional accessories see page 58, 60 & 61

SATAjet® 1000 K Specialty Spray Guns

All SATAjet 1000 K Specialty spray guns are made to order and not returnable. Please allow several weeks for delivery.

SATAjet 1000 K RP D & DA

The SATAjet 1000 K is available in a special version for the application of glues and adhesives with round fan. This nozzle set has a nozzle size of 1.6. Available with or without fan control



Technical Data	Inlet pressure: 29 psi
	Air consumption: 9.7 cfm at 29 psi
	Spray distance: 7-9" / 18-23 cm

Nozzle Size	1.5 OS	1.6 D
--------------------	--------	-------

Standard with round fan control D = Spiral OS = without control bores

Part No.	198978	161232
-----------------	--------	--------

Standard without round fan control

Part No.	-	158535
-----------------	---	--------

Nozzle Set	1.5 OS	1.6 D
-------------------	--------	-------

Part No.	196816	159707
-----------------	--------	--------

SATAjet 1000 K RP DA (dispersion adhesives)

Modified nozzle version SATAjet 1000 K for the application of dispersion adhesives, optimized atomization of waterborne adhesives without overspray and settling of adhesives at the fluid tip



Nozzle Size	1.3
--------------------	-----

SATAjet 1000 K RP DA

Part No.	211979
-----------------	--------

SATAjet 1000 K Slit Nozzle

The SATAjet 1000 K RP slit nozzle is used for high viscosity material. In the construction trade it is used for spraying spatter for a textured finish.



Technical Data	Inlet pressure: 29 psi
	Air consumption: 9.7 cfm at 29 psi
	Spray distance: 7-9" / 18-23 cm

Nozzle	25/55°	3.0/55°	4.0/79°
---------------	--------	---------	---------

Standard Gun

Part No.	154344	154351	154369
-----------------	--------	--------	--------

Nozzle Set	25/55°	3.0/55°	4.0/79°
-------------------	--------	---------	---------

Part No.	154393	154401	154419
-----------------	--------	--------	--------

SATAjet 1000 RP KK HKU Undercoating

Spray gun with round fan nozzle for the SATA HKU barrel pump system. Air connection 1/4" thread. Supplied complete with Type 1 #8359 material quick coupling for wands (material pipe not included, order separate)

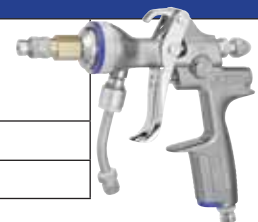

Technical Data	Inlet pressure: 29 psi
	Air consumption: 14.5 cfm at 36 psi

Nozzle Size	1.5
--------------------	-----

Standard Gun

Part No.	153700
-----------------	--------

Parts SATAJet® 1000 K Specialty Spray Guns

Part No./Descr.	
240	Seal, air piston (repair centre only)
3426	Circlip, pin
3624	Pin, air micrometer
3699	Pin, lower trigger
6395	Disc, CC (standard), pk of 4
8359	Wand coupling, small Type 1
10520	Spring, needle, 12-pk of #17897
12591	Pin, upper trigger
14605	Bushing, needle
14993	Spring, needle bushing
15438	Kit, needle packing
17152	Spring, air piston, 12-pk of #27812
17525	Washer, tension spring
17897	Spring, needle (repair centre only)
23275	Seal, needle
25486	Round spray nozzle, Type I
25874	O-Ring, 9x15, for end cap
27813	Spring, air piston (repair centre only)
31336	Paint pipe, R 3/8 to 1/4 air hose
78154	End plug
91959	Air piston
93526	Material Connection
130393	Seal, air cap ring
130435	Air cap ring only (RP)
130484	Insert w/ needle packing kit
130492	Trigger kit
130534	Air distribution ring 3-pk
133926	Kit, trigger sleeve
133942	Bushing, air piston
133959	Spring kit, 3 each of #27813 & #17897
133967	Pin, air micrometer, pk of 3
133983	Air connection piece 1/4" male thread
133991	Seal, air piston, pk of 3
139188	Kit, fluid control and lock nut
140582	Seal, fluid tip, pk of 5
153718	Mixing nozzle

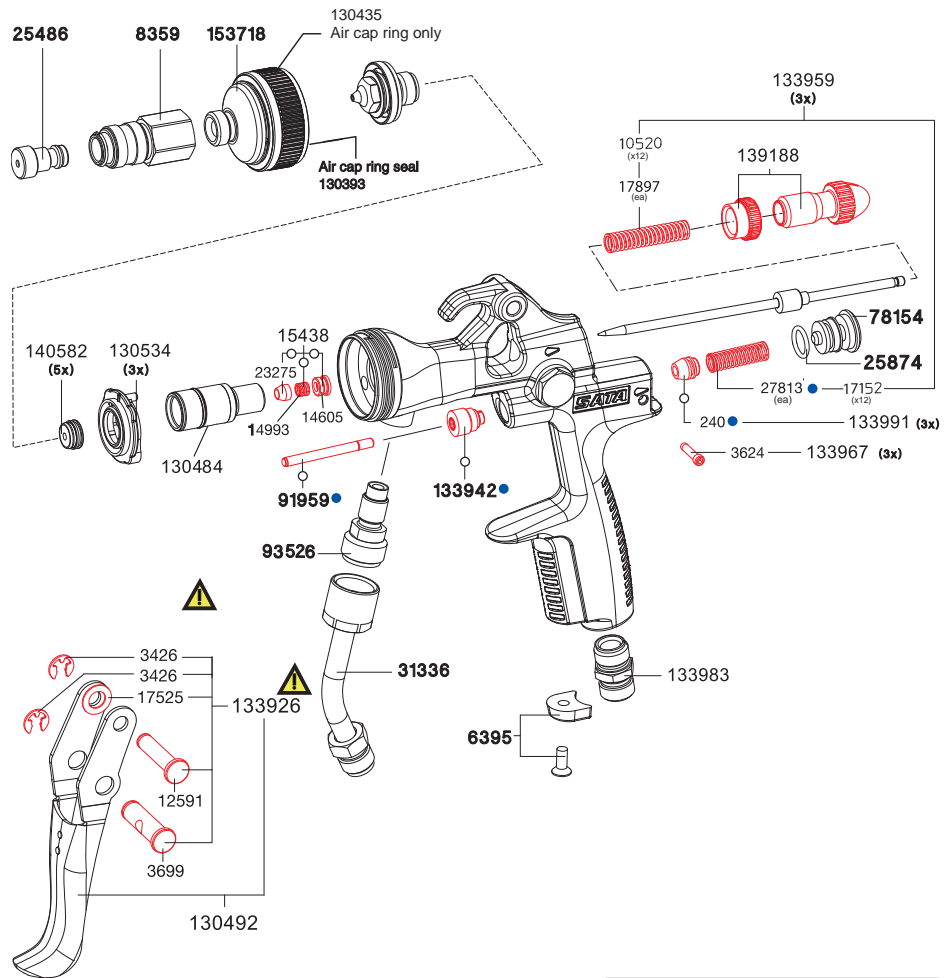

Do not remove the insert, seal, and fluid inlet. Special tools are required.

CALL SATA repair department for details.

Part No./Descr.
92577
Tool kit
· Universal spanner
· Cleaning brush
· 2 x allen wrench: 2mm & 4mm
· Torx wrench T20
· Extraction tool
· Paint sieve

Part No./Descr.
130542
Repair kit
○ 92759
Air piston service set

Technical modifications and printing errors reserved

SATAjet® 1000 H RP®



SATAjet 1000 H RP

Technical Data	Inlet pressure: 29 psi
	Air consumption: 9.7 cfm at 29 psi
	Spray distance: 6.5-8.5" / 17-21 cm



Nozzle Size	1.3	1.6	1.8	2.0
--------------------	-----	-----	-----	-----

Standard with 1.0 l aluminum siphon cup

Part No.	161034	151266	151274	153353
-----------------	--------	--------	--------	--------

Nozzle Set	1.3	1.6	1.8	2.0
-------------------	-----	-----	-----	-----

Part No.	161059	151613	151621	153379
-----------------	--------	--------	--------	--------

Standard gun without nozzle set, gun body and cup only

Part No.	154930
-----------------	--------

RPS siphon cup system, "H" guns only

Accessories for SATAjet H

188292	RPS Adapter No. 16 to use for RPS siphon cup kits. QCC Connection with G 3/8" threads
188482	RPS Siphon Kit, pins, suction hose, sieve, (for 0.3L cup), pack of 25
188516	RPS Siphon Kit, pins, suction hose, sieve, (for 0.3L cup), pack of 50
188490	RPS Siphon Kit, pins, suction hose, sieve, (for 0.6L cup), pack of 25
188524	RPS Siphon Kit, pins, suction hose, sieve, (for 0.6L cup), pack of 50
188508	RPS Siphon Kit, pins, suction hose, sieve, (for 0.9L cup), pack of 25
188532	RPS Siphon Kit, pins, suction hose, sieve, (for 0.9L cup), pack of 50

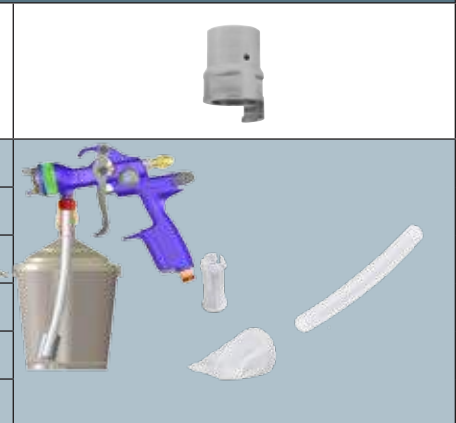

Spare Parts SATAjet® 1000 H

Part No./Descr.	
240	Seal, air piston (repair centre only)
1503	Screw, fan control
2691	Aluminum suction cup
2733	Lid fitting, complete w/ seal ring
3426	Circlip, pin
3624	Pin, air micrometer (repair centre only)
3699	Pin, lower trigger
3970	Teflon seal for air micrometer
6395	Disc, CC (standard), pk of 4
10520	Spring, needle, 12-pk of #17897
12591	Pin, upper trigger
14605	Bushing, needle
14993	Spring, needle bushing
15438	Kit, needle packing
17152	Spring, air piston, 12-pk of #27812
17525	Washer, tension spring
17897	Spring, needle (repair centre only)
23275	Seal, needle
26120	1 L aluminum suction cup w/o lid w/ rivets
27813	Spring, air piston (repair centre only)
45286	Non-drip device for suction cup (4-pk)
50195	Sieve for suction cup (2-pk)
51680	Gasket rings for suction cup (4-pk)
69872	O-ring, fan control, (repair centre only)
89771	Fan control spindle, RH w/O-ring
91959	Air piston rod
93526	Material Connection
130393	Seal, air cap ring
130435	Air cap ring only (RP)
130492	Trigger kit
130534	Air distribution ring 3-pk
133926	Kit, trigger sleeve
133934	O-ring, fan control, pk of 3
133942	Bushing, air piston
133959	Spring kit, 3 each of #27813 & #17897
133967	Pin, air micrometer, pk of 3
133983	Air connection piece 1/4" male thread
133991	Seal, air piston, pk of 3
139188	Kit, fluid control and lock nut
139964	Air micrometer, standard
140574	Knob, fan control w/screw
140582	Seal, fluid tip, pk of 5

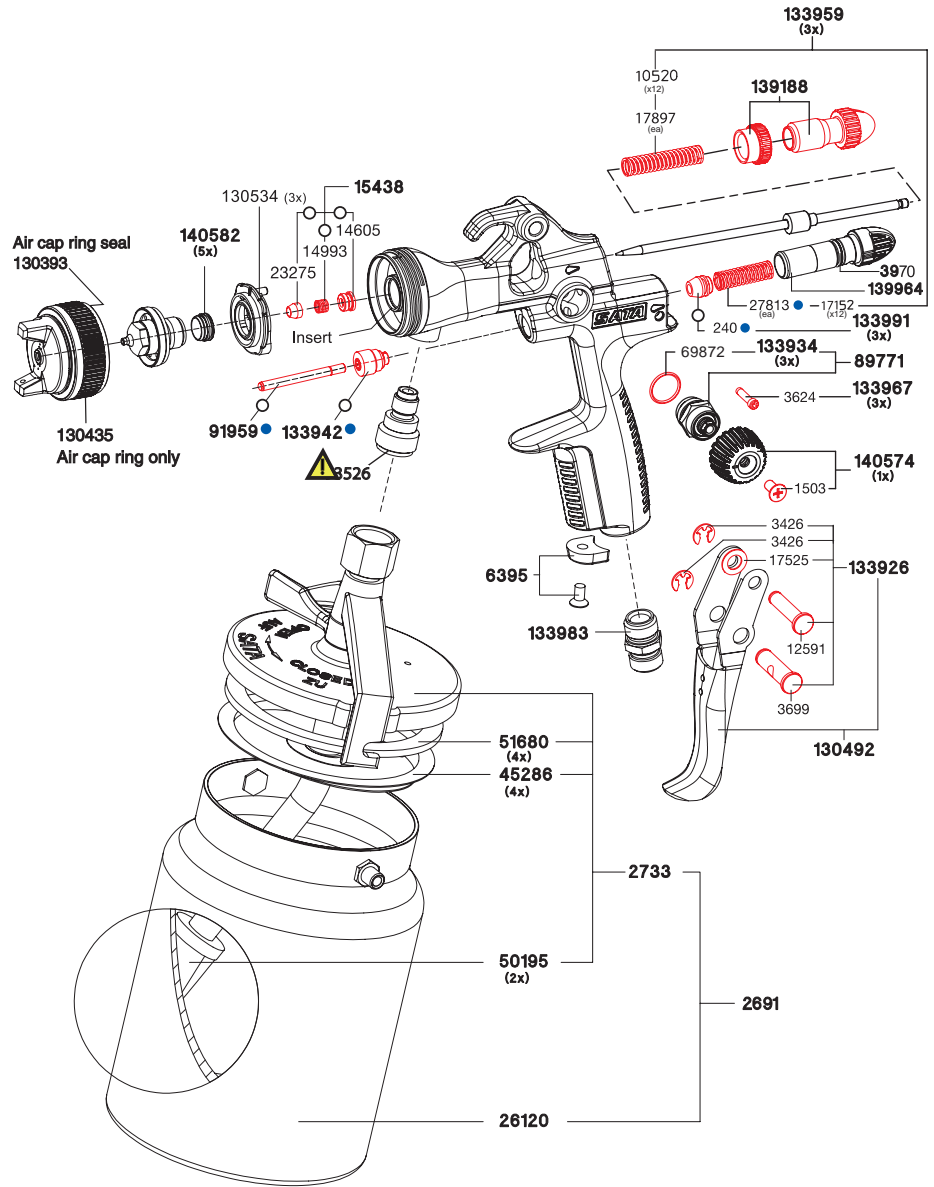

SATA adam 2

Part No./Descr.	
160853 SATA adam 2 (psi)	
160788 SATA adam 2 dock	

Part No./Descr.	
92577 Tool kit	
<ul style="list-style-type: none"> • Universal spanner • Cleaning brush • 2 x allen wrench: 2mm & 4mm • Tox wrench T20 • Extraction tool • Paint sieve 	

Do not remove the insert, seal, and fluid inlet. Special tools are required.

CALL SATA repair department for details.

Part No./Descr.
130542 Repair kit
○ 92759 Air piston service set
○ 183780 Sealing Kit

Technical modifications and printing errors reserved

SATAjet® 100 B F RP®/HVLP, SATAjet® 100 B P



SATAjet 100 B F RP

Technical Data	Inlet pressure: 21-29 psi
	Air consumption: 10.2 cfm @ 29 psi
	Spray distance: 7-9" / 18-23 cm



Nozzle Size	1.4	1.6	1.8	2.0
--------------------	-----	-----	-----	-----

Standard gun with 0.6 l QCC PVC cup

Part No.	146969	145193	145201	145219
-----------------	--------	--------	--------	--------

Standard gun with 0.75 l QCC aluminum cup

Part No.	153023	146134	146142	147421
-----------------	--------	--------	--------	--------

Standard gun with 1.0 l aluminum cup

Part No.	153460	146159	146167	147439
-----------------	--------	--------	--------	--------

Nozzle Set	1.4	1.6	1.8	2.0
-------------------	-----	-----	-----	-----

Part No.	146977	145250	145268	145276
-----------------	--------	--------	--------	--------

SATAjet 100 B P

Technical Data	Inlet pressure: 29 psi
	Air consumption: 8.7 cfm @ 29 psi
	Spray distance: 7-9" / 18-23 cm



Nozzle Size	P
--------------------	---

Standard gun with 0.6 l QCC PVC cup

Part No.	145185
-----------------	--------

Standard gun with 0.75 l QCC aluminum cup

Part No.	146217
-----------------	--------

Standard gun with 1.0 l aluminum cup

Part No.	147470
-----------------	--------

Nozzle Set	P
-------------------	---

Part No.	145284
-----------------	--------

SATAjet 100 B F HVLP

Technical Data	Inlet pressure: 29 psi
	Air consumption: 12.4 cfm at 36 psi
	Spray distance: 5-7" / 13-17 cm



Nozzle Size	1.4	1.7	1.9	2.1
--------------------	-----	-----	-----	-----

Standard gun with 0.6 l QCC PVC cup

Part No.	146373	145722	145730	145748
-----------------	--------	--------	--------	--------

Standard gun with 0.75 l QCC aluminum cup

Part No.	147447	146175	146183	147454
-----------------	--------	--------	--------	--------

Standard gun with 1.0 l aluminum cup

Part No.	146399	146191	146209	147462
-----------------	--------	--------	--------	--------

Test Air Cap	157214			
---------------------	--------	--	--	--

Nozzle Set	1.4	1.7	1.9	2.1
-------------------	-----	-----	-----	-----



Part No.	146381	145417	145425	145433
-----------------	--------	--------	--------	--------

Spare Parts SATAjet® 100 B

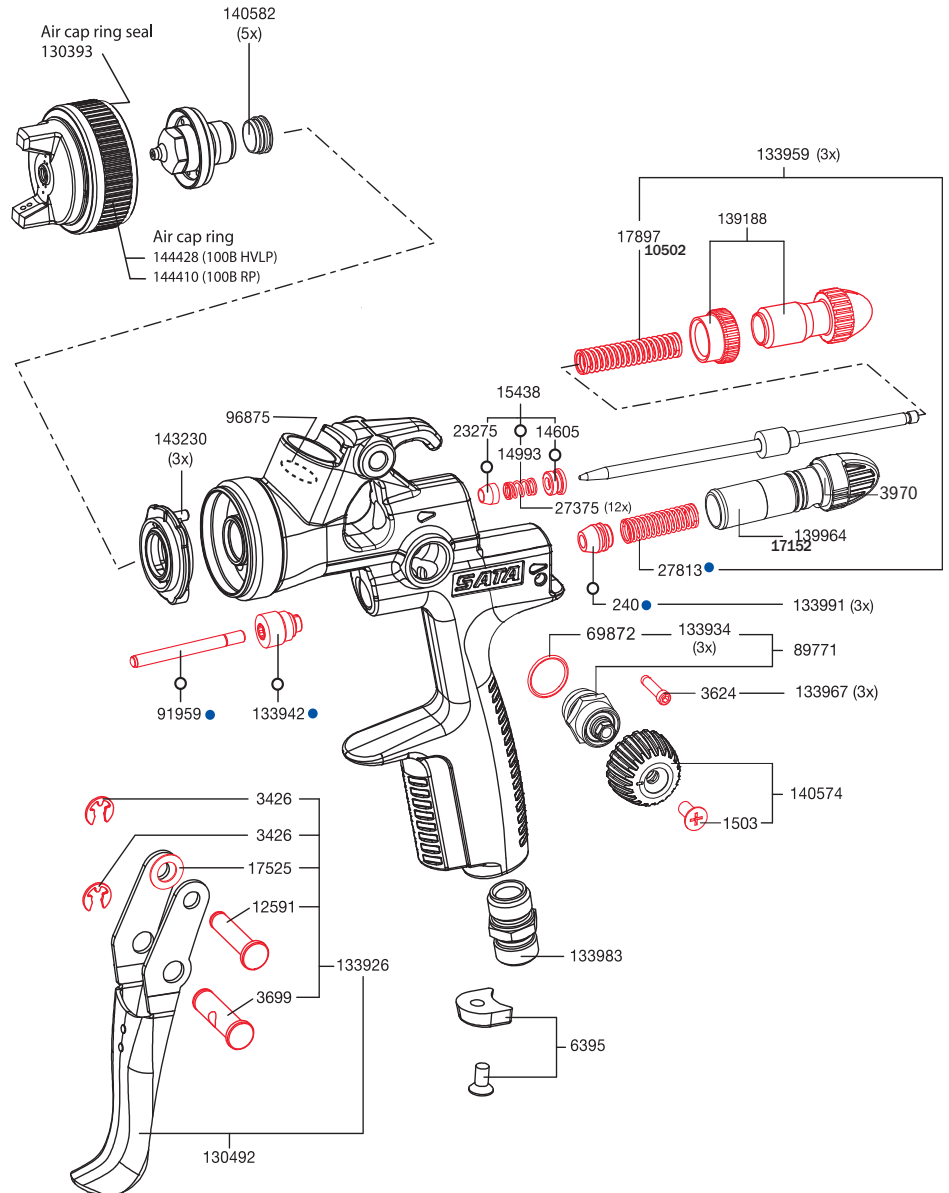
Part No./Descr.
240 Seal, air piston (repair centre only)
1503 Screw, fan control
3426 Circlip, pin
3624 Pin, air micrometer
3699 Pin, lower trigger
3970 Teflon seal for air micrometer
6395 Disc, CC (standard), pk of 4
10520 12-pk spring (single unit #17897)
12591 Pin, upper trigger
14605 Bushing, needle
14993 Spring, needle bushing
15438 Kit, needle packing
17152 12-pk spring (single unit #27813)
17525 Washer, tension spring
17897 Spring, needle
23275 Seal, needle
25874 O-ring 9 x 1.5 ("P" version only)
27813 Spring, air piston
69872 O-ring, fan control
78154 Closing Cap w/ O-ring ("P" version only)
89771 Fan control spindle, RH w/O-ring
91959 Air piston rod
96875 Seal, inner cup
130393 Seal, air cap ring
130492 Trigger kit
133926 Kit, trigger sleeve
133934 O-ring, fan control, pk of 3
133942 Bushing, air piston
133959 Spring kit, 3 each of #27813 & #17897
133967 Pin, air micrometer, pk of 3
133983 Fitting, air inlet, R 1/4"
133991 Seal, air piston, pk of 3
139188 Kit, fluid control and lock nut
139964 Air micrometer, standard
140574 Knob, fan control w/screw
140582 Seal, fluid tip, pk of 5
143230 Air distribution ring, pk of 3
144410 Air cap ring only (RP)
144428 Air cap ring only (HVLP)



SATA adam 2

Part No./Descr.	
160853 SATA adam 2 (psi)	
160788 SATA adam 2 dock	

SATAjet 100 B "P"

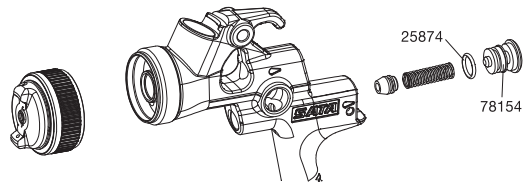

All other parts common unless stated

Part No./Descr.	
9050 Tool kit	
• Universal spanner	
• Cleaning brush	
• Allen/Trox wrench	
• Allen wrench	
• Extraction tool	

Part No./Descr.
130542 Repair kit
92759 Air piston service set
183780 Sealing Kit

SATAmijet® 1000 K RP®/HVL



SATAmijet 1000 K RP



Technical Data	Inlet pressure: 36 psi
	Air consumption: 7 cfm @ 36 psi
	Spray distance: 6.5-8.5" / 17-21 cm
	Weight: 10 oz.
	Material connection: G 1/4 male thread

Nozzle Size	0.3	0.5	0.8	1.0	1.2	1.4
--------------------	-----	-----	-----	-----	-----	-----

Spray gun

Part No.	187450	187468	187476	187484	187492	197152
-----------------	--------	--------	--------	--------	--------	--------

Nozzle set	0.3	0.5	0.8	1.0	1.2	1.4
-------------------	-----	-----	-----	-----	-----	-----

Part No.	187625	187633	187641	187658	187666	197160
-----------------	--------	--------	--------	--------	--------	--------

SATAmijet 1000 K HVL



Technical Data	Inlet pressure: 36 psi
	Air consumption: 4.2 cfm @ 29 psi
	Spray distance: 4-6" / 10-15 cm
	Material connection: G 1/4 male thread

Nozzle Size	0.3	0.5	0.8	1.0	1.2
--------------------	-----	-----	-----	-----	-----

Spray gun





Part No.	190280	190298	190306	190314	190322
-----------------	--------	--------	--------	--------	--------

Nozzle set	0.3	0.5	0.8	1.0	1.2
-------------------	-----	-----	-----	-----	-----

Part No.	190348	190355	190363	190371	190389
-----------------	--------	--------	--------	--------	--------

Test Air Cap	204875				
---------------------	--------	--	--	--	--



Accessories

187419	Paint pipe, cpl. G1/4 - G1/4	
199018	Paint pipe, cpl. G1/4 - G3/8	
187690	SATA material filter 60 msh, G 1/4	
191551	Adapter, G 1/4 female and G 3/8 male material connection	

Spare Parts SATAminijet® 1000 K

Part No./Descr.	
6395	Disc, CC (standard), pk of 4
22566	Pin, upper trigger
26583	Circlip
44644	Lock nut
44669	Spring, needle
44677	Pin, lower trigger
44735	Screw, fan control
44818	Spring, air piston
44826	Packing, air piston
44834	Air piston rod
64972	Pin, air micrometer
79905	Needle packing service set
124164	Knob, fan control
125146	Knob, fluid control
125187	Air micrometer
126037	Washer, tension spring
126276	Trigger service set
126292	Packing kit, air piston
133983	Air inlet fitting
187427	Fan control
187435	Air distribution ring, pack of 3
187344	Material connection

SATA adam 2 mini

Part No./Descr.	
160887	
SATA adam 2 mini (psi)	
160861	
SATA adam 2 dock for minijets	

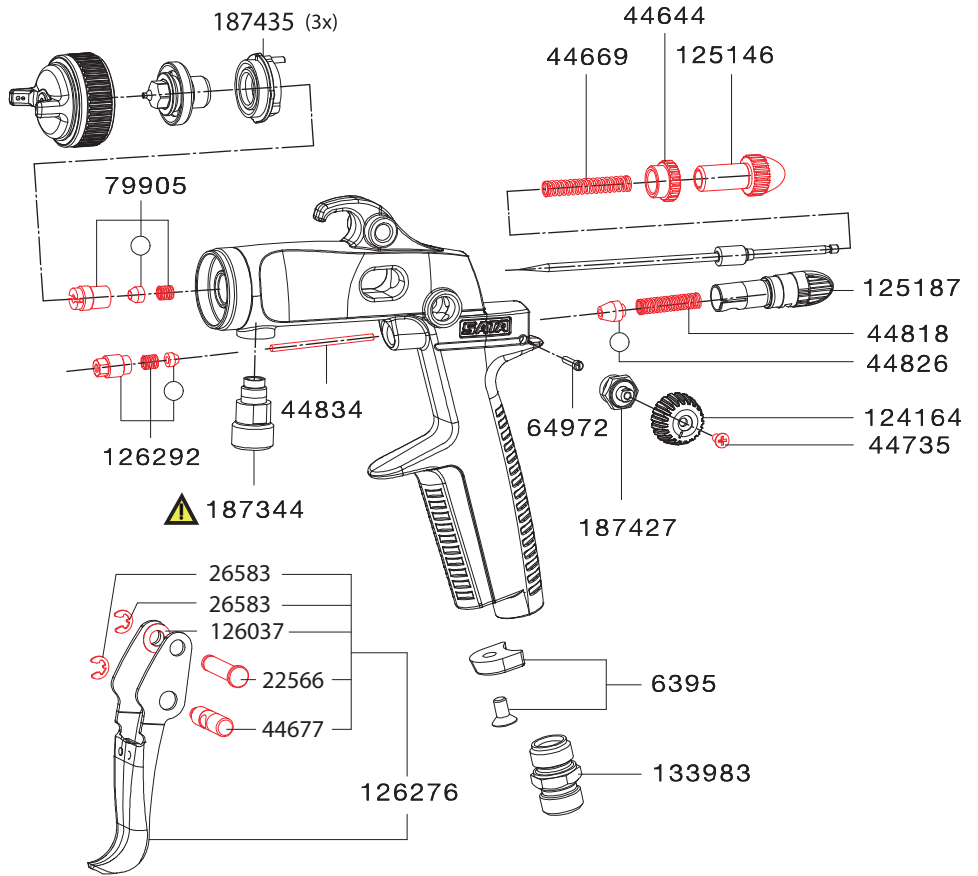

Part No./Descr.
125856
Tool kit
· Universal spanner
· Cleaning brush
· Allen wrench
· Extraction tool

Part No./Descr.
126284
Repair kit
○ 50658
Packing Kit

Do not remove the insert, seal, and fluid inlet. Special tools are required.

CALL SATA repair department for details.

For additional accessories see page 59

SATaminijet® 1000 H RP®/HVLP



SATaminijet 1000 H RP without cup

Technical Data	Inlet pressure: 36 bar
	Air consumption at 7 cfm @ 36 psi
	Spray distance: 6.5 - 8.5 in.
	Material connection: G 1/4 male thread

Nozzle 1.4



Spray gun without cup

Art. No. 187682

Nozzle set

Art. No. 187674

SATaminijet 1000 H HVLP without cup

Technical Data	Inlet pressure: 29 psi
	Air consumption at 4.1 cfm @ 29 psi
	Spray distance: 4 - 6 in.
	Material connection: G 1/4 male thread

Nozzle 1.4



Spray gun without cup

Art. No. 191502

Nozzle set

Art. No. 191494

Accessories for SATaminijet 1000

188318 RPS Adapter No. 17 To use for RPS siphon cup kits. With QCC connection thread G 1/4



188482 RPS Siphon Kit, pins, suction hose, sieve, (for 0.3L cup), pack of 25

188516 RPS Siphon Kit, pins, suction hose, sieve, (for 0.3L cup), pack of 50

188490 RPS Siphon Kit, pins, suction hose, sieve, (for 0.6L cup), pack of 25

188524 RPS Siphon Kit, pins, suction hose, sieve, (for 0.6L cup), pack of 50

188508 RPS Siphon Kit, pins, suction hose, sieve, (for 0.9L cup), pack of 25

188532 RPS Siphon Kit, pins, suction hose, sieve, (for 0.9L cup), pack of 50



Spare Parts SATAminijet® 1000 H

Part No./Descr.	
6395	Disc, CC (standard), pk of 4
22566	Pin, upper trigger
26583	Circlip
44644	Lock nut
44669	Spring, needle
44677	Pin, lower trigger
44735	Screw, fan control
44818	Spring, air piston
44826	Packing, air piston
44834	Air piston rod
64972	Pin, air micrometer
79905	Needle packing service set
124164	Knob, fan control
125146	Knob, fluid control
125187	Air micrometer
126037	Washer, tension spring
126276	Trigger service set
126292	Air piston rod packing
133983	Air inlet fitting
187427	Fan control
187435	Air distribution ring, pack of 3
187344	Material connection

SATA adam 2 mini

Part No./Descr.	
160887	SATA adam 2 mini (psi)
160861	SATA adam 2 dock for minijets

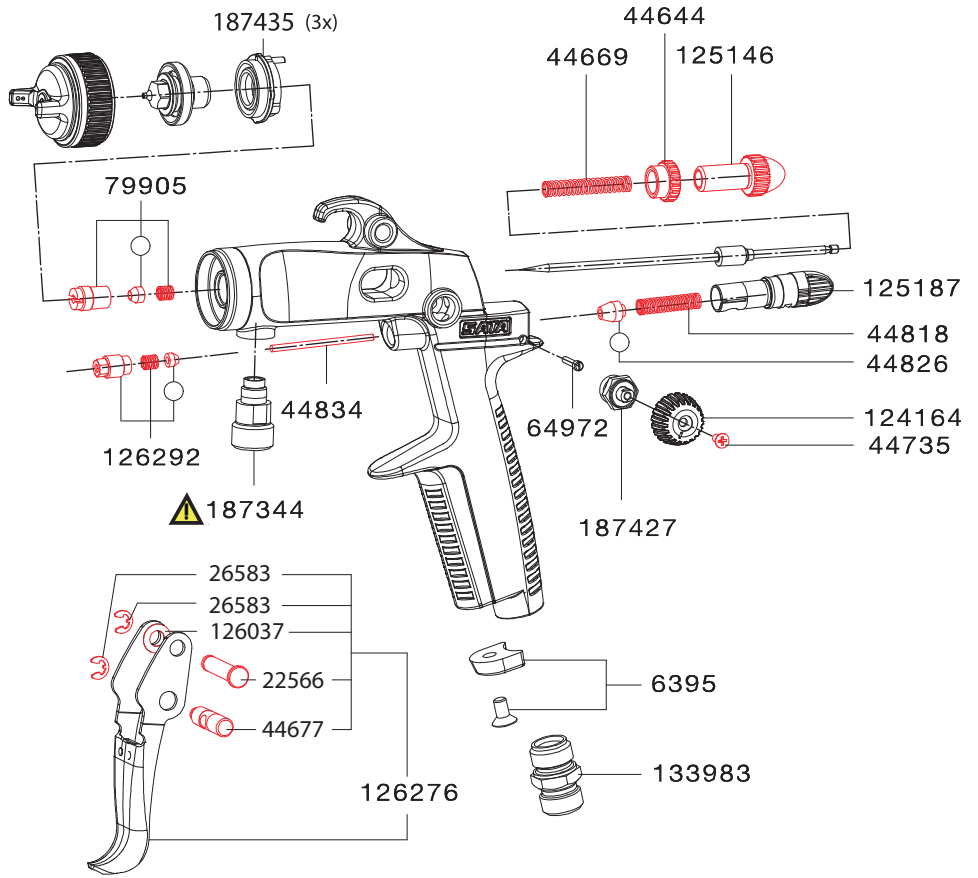

Do not remove the insert, seal, and fluid inlet. Special tools are required.

Insert

Fluid Inlet

CALL SATA repair department for details.

Part No./Descr.
125856
Tool kit
• Universal spanner
• Cleaning brush
• Allen wrench
• Extraction tool

Part No./Descr.
126284
Repair kit
50658
Packing Kit

Technical modifications and printing errors reserved

SATAjet® 20 B



SATAjet 20 B

Conventional Gravity or Siphon Design Gun

Use for hobbies, silk screening, lettering, graphic arts, woodworking or unique design.

An endless list of possibilities for any kind of design work make the SATAjet® 20 B a great choice. This round spray design gun is perfect for vehicle murals, graphic design, calligraphy, airbrushing and many hobbies. Five nozzle sizes from 0.2 to 1.0 add to its versatility. Two separate air inlets may be interchanged without any tools - in the handle or at the backside of the gun. That means it can be handled like a typical spray gun or like an airbrush. The unique design of the SATAjet 20 B allows it to be used by left- or right-handed artists. The gravity cup is easily removed and an adapter switches it to a siphon gun with plug-in cups. These plug-in cups allow quick and easy changing of one color to the next.

The SATAjet 20 B is an excellent choice for a glazing spray gun for the wood industry.

With a controlled application, the material savings and wiping time are significantly reduced.

Nozzle sets with stainless steel needle and fluid tip are standard making them compatible for waterborne. The SATAjet 20 B has self-adjusting Teflon seals and the gun body is finished in durable nickel plating.

Lightweight at only 6.3 oz and low air consumption at 1.4 cfm @ 15 psi makes it ideal for continuous work load. Additionally it can be converted to a pressure fed spray gun for continuous work (call for setup).

The most common nozzle size for applying glaze and wiping is 0.5. For pinpoint glazing and no wiping use a 0.2 nozzle.



Technical Data

Inlet pressure: 15 psi

Air consumption: 1.4 cfm at 15 psi

Spray distance: variable

Nozzle Size	0.2	0.2 F*	0.35	0.35**	0.5	0.8	1.0
-------------	-----	--------	------	--------	-----	-----	-----

Spray gun with 65 ccm plastic cup

Part No.	65078	189035	65581		65649	66316	69229
----------	-------	--------	-------	--	-------	-------	-------

Spray gun with 1 plug-in cap and 4 blind cups, including adapter

Part No.	86181	call	86199	-	86207	86215	86223
----------	-------	------	-------	---	-------	-------	-------

Nozzle Set	0.2	0.2 F*	0.35		0.5	0.8	1.0
------------	-----	--------	------	--	-----	-----	-----

Part No.	60459	189043	60640	202515**	61200	61341	61523
----------	-------	--------	-------	----------	-------	-------	-------

*F = Fineline ** Lifetime prolonging surface treatment

SATA jet 20 B design set

90381	SATAjet 20 B design set:	<ul style="list-style-type: none"> · SATAjet 20 B spray gun · 1) 0.5 nozzle · 1) 0.025 l glass plug-in cup · 1) air micrometer w/ gauge · 1) funnel/sieve · 1) 6 ft PVC hose 	<ul style="list-style-type: none"> · 1) 0.2 nozzle (Specify nozzle size or will ship with 0.2) · 4) 25 ml glass cup w/ blind lid · 1) adapter · 1) packing set · 1) cleaning set · 1) gun holder
-------	--------------------------	--	--



Accessories for SATA pressure fed spray guns

69328	Gun holder, gravity or siphon cup
53033	Plug-in cups, pack of 5
58164	Plain cups, pack of 5
60350	Plug-in cup adapter & set of 5 plug-in cups with funnel
125955	Plug-in cup adapter



Spare Parts SATAjet® 20 B

Part No./Descr.	
9860	Air micrometer without gauge (sold separately)
9878	Mini water separator (sold separately)
15669	65cc plastic gravity cup
15909	65cc cup lid
16295	25 ml plug-in cup, complete
32987	Air hose, PVC, w/QC nipple
22566	Pin, upper trigger
26583	Circlip
44677	Pin, lower trigger
44818	Spring, air piston
44826	Packing, air piston
44834	Air piston
50807	Air piston service set
52282	Bushing, air piston
52373	QC nipple
53033	25 ml plug-in cup, pk of 5
54353	Air hose, PVC, 2m, w/ fittings
55749	Trigger
58164	25 ml glass cup, pk of 5
62042	Spray gun handle
62083	Air tube
62398	Nozzle spindle, Dekor 2000
62729	End screw
62802	Compression bushing
62810	Needle packing
62851	Needle bushing
62869	Knob, fluid control
64758	O ring, 8x1
66928	Air inlet fitting
68809	Spring, needle packing
68817	Spring, needle
69344	Needle packing service set
74351	Gasket, air hose
79913	Trigger service set
125955	Plug-in cup connection
125963	Plug-in cup set, connection adapter, 5 glass cups 25cm, 1 plug-in lid, 4 blind lids

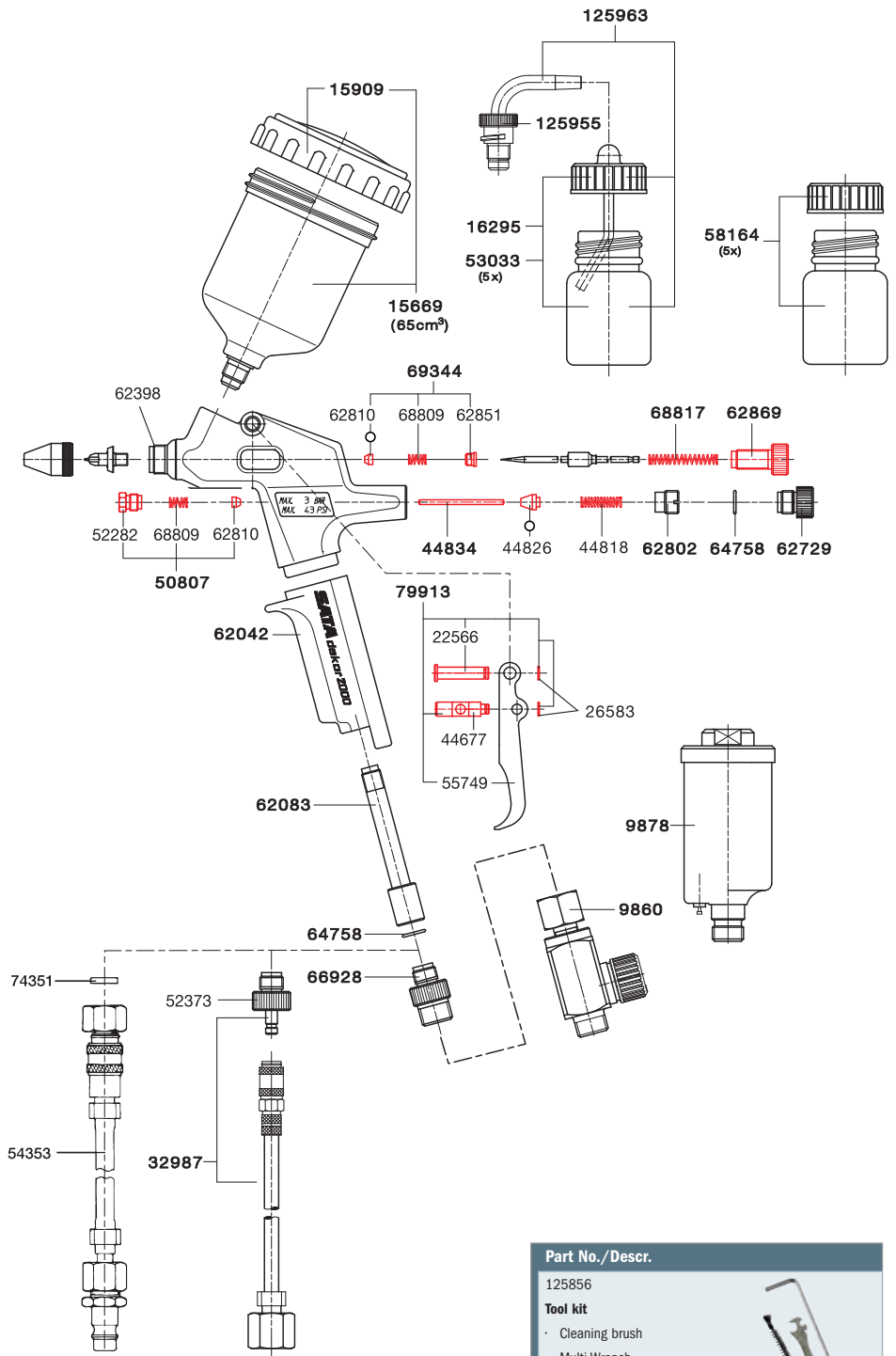

Part No./Descr.	
125856	Tool kit
	<ul style="list-style-type: none"> · Cleaning brush · Multi Wrench · Hex screwdriver

Part No./Descr.	
91165	Repair kit
69427	Packing Kit

Technical modifications and printing errors reserved

SATAgraph™ 1/2/3

1 - The Starter Model

Technical Data	Inlet pressure: variable
	Air consumption: 0.4 cfm at 14 psi
	Spray distance: variable



Nozzle Size	0.25	0.45
--------------------	------	------

SATAgraph 1 - with 2.5 ml gravity cup, no air hose

Part No.	134544	136069
-----------------	--------	--------

SATAgraph 1 - with 5.0 ml siphon cup, no air hose

Part No.	139568	141408
-----------------	--------	--------

Nozzle Set	0.25	0.45
-------------------	------	------

Part No.	134619	134635
-----------------	--------	--------



SATAgraph 2 - The Universal Airbrush

Technical Data	Inlet pressure: variable
	Air consumption: 0.4 cfm at 29 psi
	Spray distance: variable



Nozzle Size	0.20	0.25
--------------------	------	------

SATAgraph 2 with 4.0 ml gravity cup, 15.0 ml siphon cup, no air hose

Part No.	135079	134536
-----------------	--------	--------

SATAgraph 2 with 4.0 ml gravity cup, 15.0 ml siphon cup, & 3 m PVC air hose

Part No.	123430	5082
-----------------	--------	------

Nozzle Set	0.20	0.25
-------------------	------	------

Part No.	123448	31476
-----------------	--------	-------



SATAgraph 3 - Premium Airbrush for Professionals

Technical Data	Inlet pressure: variable
	Air consumption: 0.4 cfm at 36.3 psi
	Spray distance: variable



Nozzle Size	0.15	0.25	0.45	0.65
--------------------	------	------	------	------

SATAgraph 3 - with 2.5 ml gravity cup, no air hose

Part No.	136077	134569	136085	-
-----------------	--------	--------	--------	---

SATAgraph 3 - with 5.0 ml siphon cup, no air hose

Part No.	-	134585	136093	136101
-----------------	---	--------	--------	--------

Nozzle Set	0.15	0.25	0.45	0.65
-------------------	------	------	------	------

Part No.	134643	134650	134668	134676
-----------------	--------	--------	--------	--------



Spare Parts SATAgaph™ 1/2/3

Part No./Desc.	
SATAgaph 1	
32615	Coupling nipple, Pk of 3
134767	2.5 ml gravity flow cup w/ lid
134775	5.0 ml gravity flow cup w/ lid
134783	5.0 ml siphon cup w/ lid
134809	Trigger
134825	Grip end piece
138909	O-ring kit for paint nozzle (5-pieces)
142638	O-ring kit for gravity flow cup (5-pieces)

Part No./Desc.	
SATAgaph 2	
31781	4.0 ml gravity flow cup w/ 3 plastic lids
32029	Plastic lids for 4.0 ml gravity flow cup, pk of 3
32615	Pk of 3 coupling nipples
33001	Grip / end piece
33019	15 ml glass cup w/ lid and suction pipe
33092	15 ml glass cups, 5 closing lids and 1 lid with suction pipe, pk of 5
35964	Needle cap
36020	Trigger
138909	O-ring kit for paint nozzle (5-pieces)

Part No./Desc.	
SATAgaph 3	
32615	Pk of 3 coupling nipples
134767	5.0 ml gravity flow cup w/ lid
134775	5.0 ml gravity flow cup w/ lid
134783	5.0 ml siphon cup w/ lid
134817	Needle cap
134833	Grip end piece, cpl.
134957	Trigger
138909	O-ring kit for paint nozzle (5-pieces)
142638	O-ring kit for gravity flow cups (5-pieces)

See hoses, page 147

SATAgaph 1

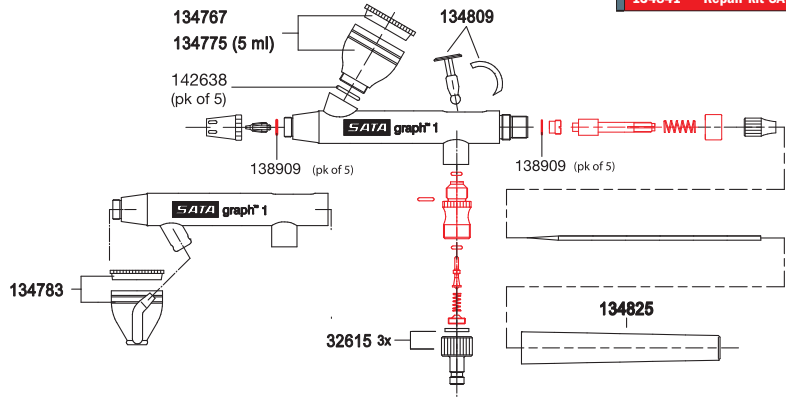

SATAgaph 2

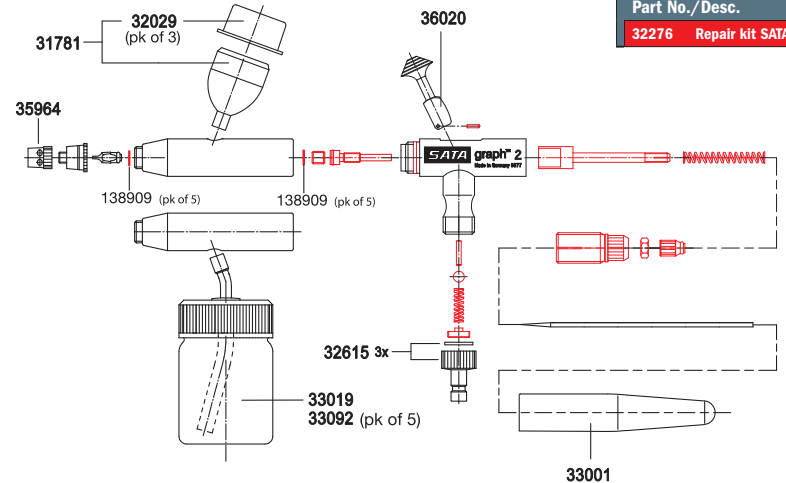

SATAgaph 3

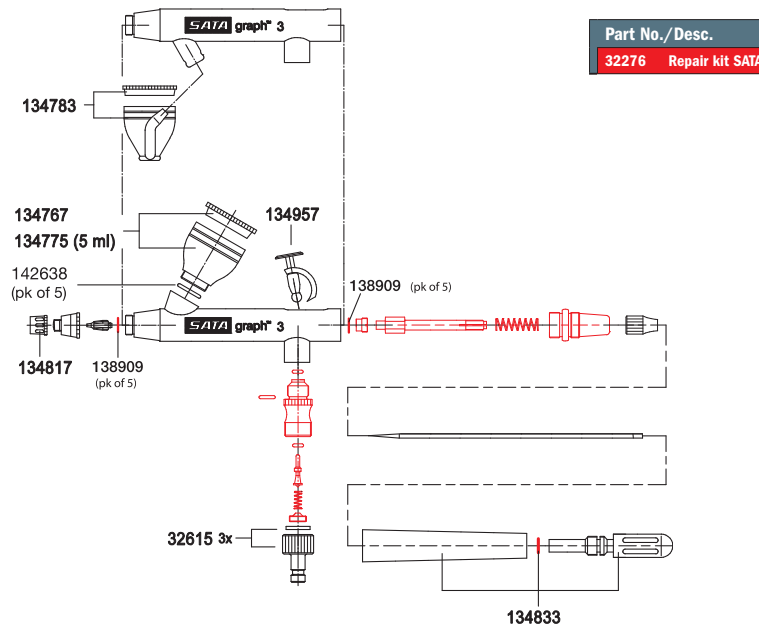

SATAgaph™ 4

SATAgaph 4 B - Gravity Feed

Technical Data	Inlet pressure: variable
	Air consumption: 0.4 cfm at 14.5 psi
	Spray distance: variable
Nozzle Size	0.4



SATAgaph 4 B with 2.5 ml gravity cup, no air hose

Part No.	S004B
Needle Only	0.4
Part No.	S005



SATAgaph 4 S - Side Feed

Technical Data	Inlet pressure: variable
	Air consumption: 0.4 cfm at 14.5 psi
	Spray distance: variable
Nozzle Size	0.4



SATAgaph 4 S with 2.5 ml side feed cup, no air hose

Part No.	S004S
Needle Only	0.4
Part No.	S005



SATAgaph 4 H - Siphon Feed

Technical Data	Inlet pressure: variable
	Air consumption: 0.4 cfm at 14.5 psi
	Spray distance: variable
Nozzle Size	0.4



SATAgaph 4 S with 2.5 ml siphon cup, no air hose

Part No.	S004H
Needle Only	0.4
Part No.	S005



SATAgaph 4 B, H, K

SATAgaph 4, 3 gun kit includes all 3 SATAgaph 4 airbrushes, S004B, S004S and S004H also included is a (1) S0323, 3/4 oz glass jar with siphon lid, (1) S039, 1 oz. glass cup with side feed lid, (1) S045, 6 ft braided hose with quick disconnect, (3) Quick connect plug/fittings, female, (1) foam padded case with handle. Special order item, non-returnable.

Nozzle 0.40

SATAgaph 4 HBS three gun kit

Part No.	S004HBS
Needle Only	0.4
Part No.	S005



Spare Parts SATAgaph™ 4 B/S/H

Part No./Desc.	
S001	Airbrush needle, 0.40
S002	Nozzle tip (fluid tip)
S003	Nozzle cap (inner air cap)
S004	Nozzle cap shield (outer aircap nozzle shield reversible)
S005	Needle/nozzle refurbish kit (includes 001, 002, 003, 004)
S006	Nozzle base
S007	O-ring, nozzle base
S008	Nozzle base wrench
S009	Air valve chamber
S010	Trigger valve stem
S011	Trigger valve spring
S012	Air valve seal / o-ring
S013	Air valve screw
S014	Complete air valve assembly (includes 009, 010, 011, 012, 013)
S015	Inner seal screw and O-ring (gravity and side cup models)
S016	Airbrush trigger
S017	Needle alignment tube and lever assembly
S018	Needle tube spring
S019	Spring tension adjustment knob
S020	Needle locking nut
S021	Needle alignment and adjustment assembly (includes 017, 018, 019, 020)
S022	Bottom (siphon) feed airbrush body
S023	Gravity feed airbrush body
S024	Side feed airbrush body
S025	O-ring, airbrush handle
S026	Trigger stop set handle, red
S027	Trigger stop set screw
S028	Trigger stop set handle and screw (includes 026, 027)
S029	Protective nozzle cover
S030	Siphon lid, metal, fits 3/4 oz. glass cup
S031	3/4 oz. glass cup w/blank storage lid for (S)
S032	3/4 oz. glass cup w/siphon lid for (S)
S033	1/4 oz. color cup (siphon cup-metal)
S034	Side feed metal color cup
S035	Side feed inlet plug, red
S036	Lid, metal, for side (S) and gravity (B) feed color cup
S037	Lid, metal side feed lid for 1 oz. glass cup
S038	1 oz. glass cup w/blank metal storage lid
S039	1 oz. glass cup with metal side feed lid
S040	6 foot braided air hose 1/8 inch X 1/4"
S041	10 foot braided air hose 1/8" X 1/4"
S042	6 foot braided air hose w/ moisture trap
S043	10 foot braided air hose w/ moisture trap
S044	In-line moisture trap
S045	8 foot quick dis-connect braided air hose
S046	Quick disconnect plug/fitting, female
S047	Siphon lid, plastic, fits 3/4 oz. glass cup
S048	3/4 oz. glass cup w/siphon lid for (S)
S049	Pvc lid for 1/4 oz metal siphon color cup
S050	Quick dis-connect air coupler, male
S051	PVC color cup lid Gravity feed (B) and Side feed (S).
S004B	SATAgaph 4 B Gravity feed airbrush
S004S	SATAgaph 4 S Side-feed airbrush
S004H	SATAgaph 4 H Bottom-feed siphon airbrush

SATAgaph 4B Gravity cup S004B

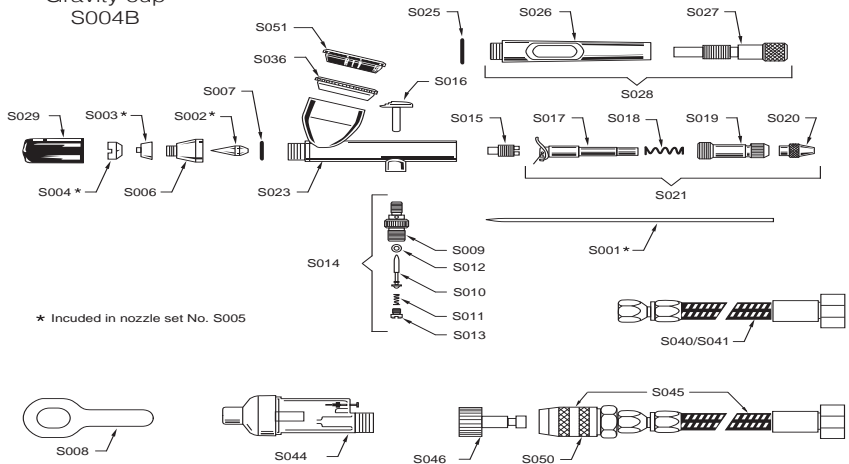

* Included in nozzle set No. S005



SATAgaph 4S w/side mount cup S004S

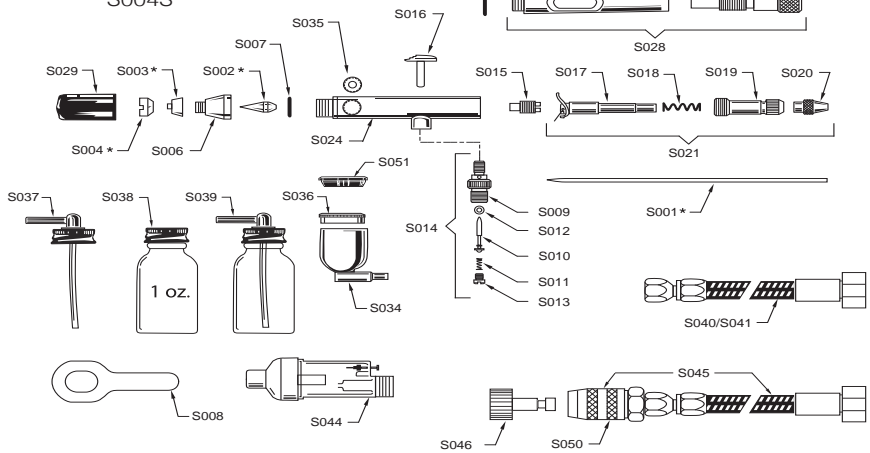

* Included nozzle set No. S005

SATAgaph 4H w/siphon cup S004H

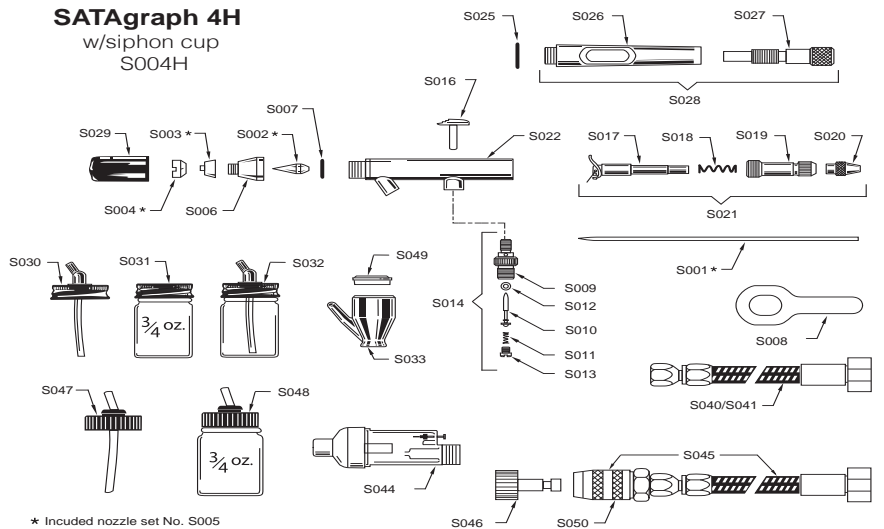

* Included nozzle set No. S005

Nozzle Sets for Older Model SATA Spray Guns

SATA Spray Guns

Nozzle Size	SATAjet 90-2 HVLP	SATAJET 90-2 RP	SATAjet 3000 HVLP	SATAjet 3000 RP	SATAjet 2000 HVLP	SATAjet RP	SATAjet B	NR92/95 HVLP	SATAjet K NR-92 NR-95 HVLP	SATA MC-B HVLP	SATA Jet 90
0.2											
0.3											
0.4											
0.5									73908		
0.8									79780		
0.8SR											
0.9											
1.0			132910	132357	82024	29587	4143	NLA	79798		
1.0SR											
1.1				158667							
1.2			132928	132365	82057	14902		NLA	79806		
1.2SR											
1.3	126102	123257	132936	132373	NLA		4127	NLA			56051
1.3 LV						14910					
1.3 C											
WSB			132993		9191						
1.4	126110	123265	132944	132381	82263	14936	3848	NLA	79277	52324	56077
1.4 HC			145797								
1.4 SR											
1.5			132951		82420		4119	46185			
1.6				132399		14977					51482
1.6 NA											
1.7			132969		90399	97998	4101	NLA	NLA	NLA	
1.8				132407							
1.9			132977		90407	69880		50138		NLA	
2.0				132415			NLA				
2.1										NLA	
2.2			132985		90415	69898		46201			
2.5				132423			NLA				
P											
2.6											
3.0											
4.0											
5.0											
Repair Kits	57620	57620	133835	133835	57620	57620	9720	NR95 - NLA NR92 (9720)	70623	71464	57430

* Above serial number 85,000 (below 85,000 - part no. 55178)

** Above serial number 6,000 (below 6,000 - part no. 69377)

NOTE - Nozzles that are both out of production and sold out are marked as NLA - No Longer Available

Nozzle Sets for Older Model SATA Spray Guns

SATA Spray Guns

SATA ◆ Jet/K ▲ Jet/H	SATA MC-B MC-93	SATA LM 92 B, H, K	SATA minijet 4 & 3000 B	SATA minijet 2 & 3 HVLP	SATA minijet HVLP Green	SATA dekor	SATA KLC-B HVLP	SATA KLC RP	SATA LM2000 B, H, K RP	SATA LM2000 B, H, K HVLP	Nozzle Size
						5298					0.2
			125583	91041							0.3
						5280					0.4
			125591	91058		5272					0.5
◆ 61358		NLA	125609	91066	57240	5264			26690		0.8
			125682	53454							0.8SR
										26823	0.9
		NLA	125617	91074	57398	5256			26716		1.0
			125690	51318							1.0SR
◆ 55814			125625	91082	NLA					26856	1.1
											1.2
			125708	88534							1.2SR
◆ 64592	NLA	NLA						87973	26724	26864	1.3
											1.3 LV
											1.3 C
											WSB
							32748			30106	1.4
											1.4 HC
			125716								1.4 SR
◆64600 ▲23663										26872	1.5
	NLA	NLA						NLA	26732		1.6
								88005			1.6 NA
▲ 23697							32755			30643	1.7
	NLA	NLA						96768	26740		1.8
							32771			30742	1.9
▲ 23689	NLA	NLA						87999	26757		2.0
							33415			31047	2.1
											2.2
		NLA						88013	26765		2.5
											P
											2.6
		NLA							26781		3.0
									26799		4.0
									26807		5.0
70623	71464	562	126284	50815	50815	91165	12633	12633	54957	54957	Repair Kits

* Above serial number 85,000 (below 85,000 - part no. 55178)

** Above serial number 6,000 (below 6,000 - part no. 69377)

NOTE - Nozzles that are both out of production and sold out are marked as NLA - No Longer Available

SATAjet® 3000 B RP®/HVLP



Out of Production - Replacement parts available until 2019, inquire for availability

SATAjet 3000 B RP

Nozzle Set	1.0	1.2	1.3	1.4	1.6	1.8	2.0	2.5
Part No.	132357	132365	132373	132381	132399	132407	132415	132423

SATAjet 3000 B HVLP

Nozzle Set	1.0	1.2	WSB	1.3	1.4	1.5	1.7	1.9	2.2
Part No.	132910	132928	132993	132936	132944	132951	132969	132977	132985

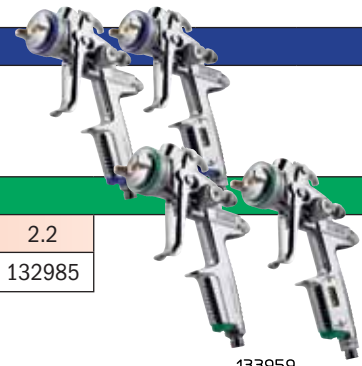

Part No./Descr.	
240	Packing, air piston (repair centre only)
3426	Circlip only, 1 each (repair centre only)
3699	Pin, lower trigger (repair centre only)
3988	Sieve, pk of 10
10520	Spring, paint needle 12-pk
12591	Pin, upper trigger (repair centre only)
14605	Bushing, needle packing (repair centre only)
14993	Spring, needle packing (repair centre only)
15438	Kit, needle packing
17152	Spring, air piston 12-pk
17525	Washer, trigger sleeve
17897	Spring, paint needle (repair centre only)
19745	Swivel joint, for standard gun
23275	Packing, needle (repair centre only)
27813	Spring, air piston (repair centre only)
38638	Air distribution ring (repair centre only)
86843	Piston, air rod
89771	Fluid Control, w/"O" ring
96875	Inner cup seal
97824	Air distribution ring, 3-pk w/ tool
131623	O ring, fan control, (small)
133462	RP air cap ring w/ seal
133470	HVLP air cap ring w/ seal
133850	Kit, trigger service complete
133884	Kit, battery, cover w/gasket
133926	Kit, trigger sleeve
133934	Seal ring for fan control 3-pk
133942	Bushing, air piston
133959	Spring kit, 3 each of #27813 & #17897
133876	Digital air inlet w/ seal retainer & swivel joint
133975	Digital air inlet w/ seal retainer
133991	3-Pk packing, air piston
134015	Air micrometer
134023	Lock nut, material fluid control
134031	Fan control knob
134056	Right hand fan control
134098	Air inlet fitting
143834	Air cap seal ring, 5-pk
203414	Swivel joint with seal retainer and sleeve

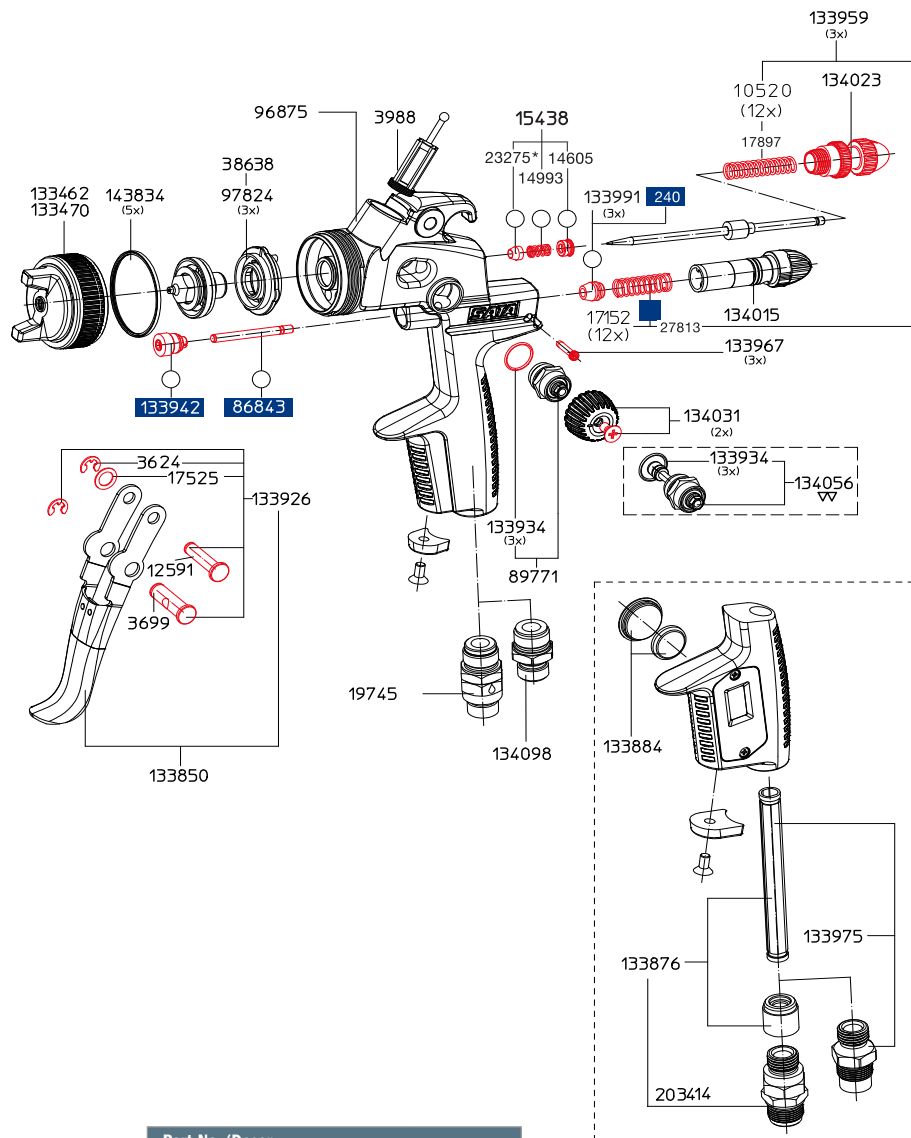

Part No./Descr.
9050
Tool kit
· Universal spanner
· Cleaning brush
· Allen/Trox wrench
· Allen wrench
· Extraction tool

Part No./Descr.
133835
Repair kit
<input type="radio"/> 82552
Air piston service set
<input type="radio"/> 136960
Sealing Kit

SATAjet® 90-2

Out of Production - Replacement parts available, inquire for availability

SATAjet 90-2 RP

Nozzle Set	1.3	1.4
Part No.	123257	123265

SATAjet 90-2 HVLP

Nozzle Set	1.3	1.4
Part No.	126102	121110



Part No./Descr.

109	Air inlet fitting
240	Air piston packing (Repair centre only)
1503	Fan control screw
3426	Circlip, pin
3624	Pin, micrometer
3657	Knob, fan control
3699	Pin, lower trigger
3988	Paint sieve, 10-pk
6213	Trigger Service Set
10520	Needle spring 12-pk
12591	Pin, upper trigger
14605	Bushing, needle packing
14993	Packing spring, each
15438	Needle packing service set
17152	Air piston spring 12-pk
17525	Washer, tension spring
17897	Needle spring, (Repair centre only)
23275	Needle packing
26518	Fluid control service set
27813	Air piston spring, (Repair centre only)
50146	Fluid regulating control
50542	Lock nut, fluid control
53603	Air micrometer
69872	Control O ring
82636	Bushing, air piston
86843	Air piston
89391	Trigger
89771	Fan control
123166	Air cap ring w/ seal, Blue (RP)
132174	Air cap ring w/ seal, Green (HVLP)
123455	Air ring, 3 pk
133991	Air piston packing 3-pk

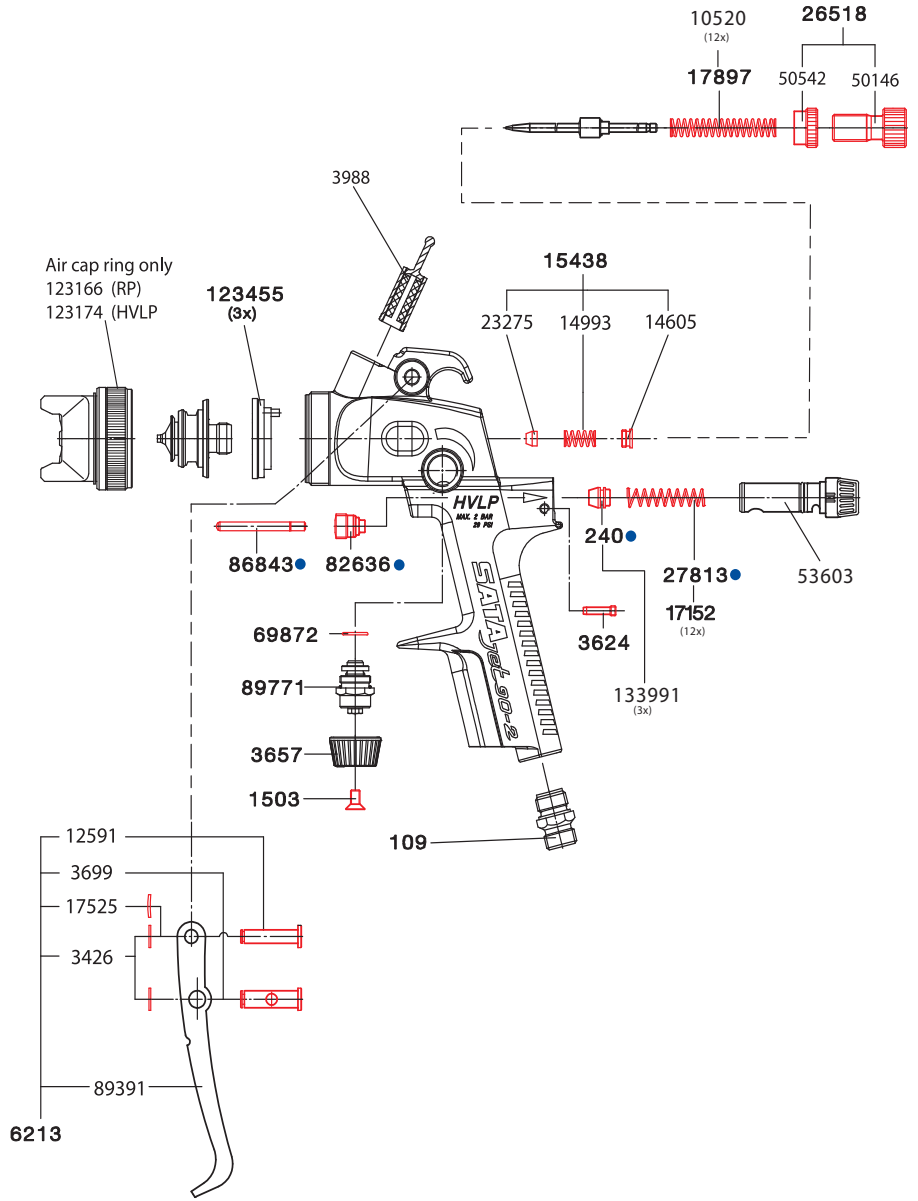

Part No./Descr.

- 9050
Tool kit
- Universal spanner
 - Cleaning brush
 - Allen/Trox wrench
 - Allen wrench
 - Extraction tool



Part No./Descr.

- 57620
Repair kit
- 82552
Air piston service set
- 136960
Sealing Kit

Technical modifications and printing errors reserved

SATAjet® 2000 B HVLP & SATAjet B RP



Out of Production - Replacement parts available until 2017 for RP and 2015 for HVLP, inquire for availability

SATAjet 2000 B RP

Nozzle Set	1.0	1.2	1.3	1.4	1.6	1.8	2.0	2.5
Part No.	29587	14902	14910	14936	14977	97998	69880	69898

SATAjet 2000 B HVLP

Nozzle Set	1.0	1.2	WSB	1.3	1.4	1.5	1.7	1.9	2.2
Part No.	82024	82057	9191	NLA	82263	82420	90399	90407	90415

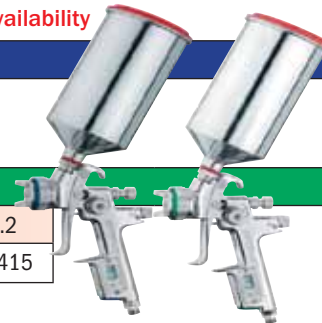

Part No./Descr.	
240	Air piston packing
1503	Fan control screw
3418	Packing washer (Repair centre only)
3426	Circlip, pin (Repair centre only)
3624	Pin, micrometer (Repair centre only)
3657	Knob, fan control
3699	Pin, lower trigger (Repair centre only)
6213	Trigger service set, Jet 2000, RP
7757	CCS clips
10033	Air cap ring w/seal, Jet RP
12591	Pin, upper trigger
14605	Bushing, needle packing
14985	Battery kit, digital
14993	Spring, needle packing
15438	Needle packing service set
17525	Lock spring
17897	Needle spring
23275	Needle packing
26518	Fluid control service set
27813	Air piston spring
37788	Packing seal (Repair centre only)
38638	Air ring, SATAjet 2000, SATAjet RP Digital & Std. (Repair centre only)
40774	Needle packing spring (Repair centre only)
43174	Air cap ring w/seal, Jet 2000
45971	Air distribution ring (s/n 43699 and down)
50146	Fluid regulating control
50542	Lock nut, fluid control
52845	Needle packing holder (Repair centre only)
53603	Air micrometer
55848	Air inlet fitting, standard guns
69872	Control O-ring
77677	Needle packing service set (s/n 43699 and down)
82636	Air piston packing holder
86843	Air piston
89391	Trigger
89771	Fan Control
89805	Snap ring (air cap)
95091	Air inlet fitting, DIGITAL
96875	Inner cup seal
97824	Air distribution ring, 3-pk w. tool
134098	Air inlet fitting, std. gun
143834	Seal, air cap ring, 5 pk

SATAjet 2000 B Serial No. 43700 and up

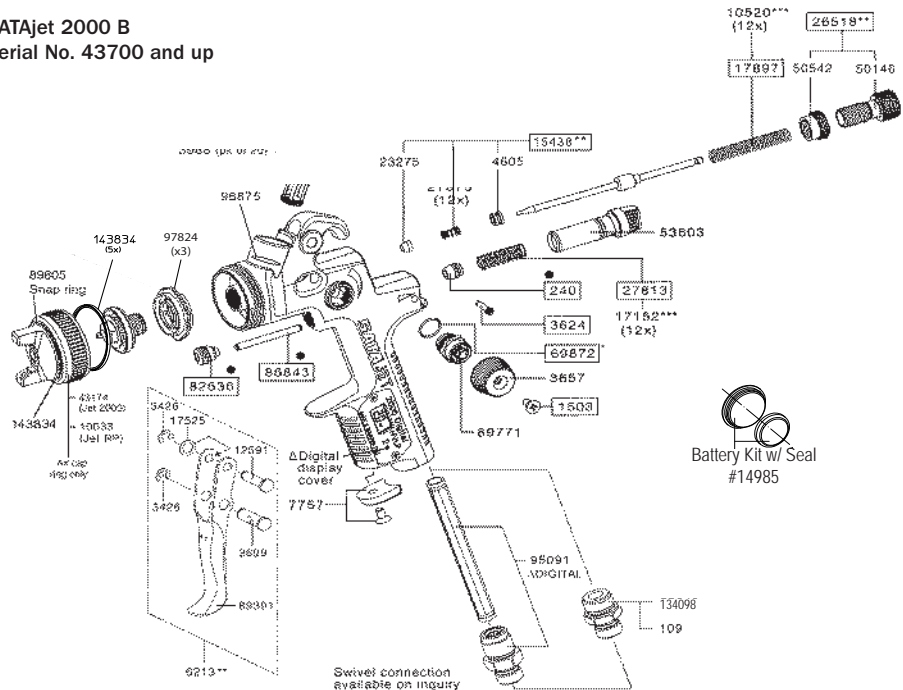

SATAjet 2000 B Serial No. 43699 and down

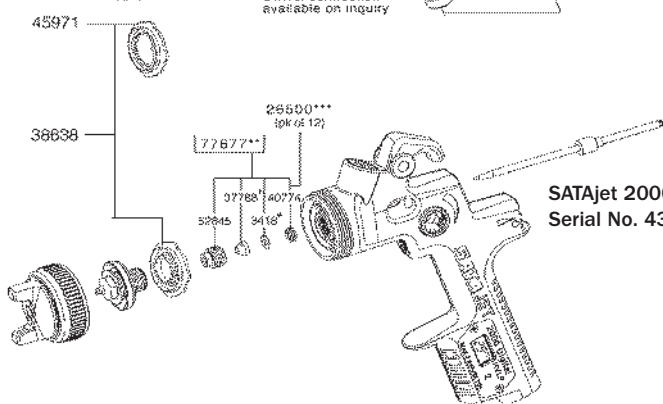

Part No./Descr.

- 9050
Tool kit
- Universal spanner
 - Cleaning brush
 - Allen/Trox wrench
 - Allen wrench
 - Extraction tool



Part No./Descr.

- 57620
Repair kit
- 82552
Air piston service set
- * 55244
Packing set
- ** Parts that are available separately from
Packing set



SATaminijet® 3000 B HVLP

Out of Production - Replacement parts available

SATaminijet 3000 B HVLP

Nozzle Set	0.3	0.5	0.8	1.0	1.1	0.8 SR	1.0 SR	1.2 SR	1.4 SR
Part No.	125583	125591	125609	125617	125625	125682	125690	125708	125716



Part No./Descr.	
6395	CCS Discs
22566	Pin, upper trigger
26583	Circlip
35600	Cup Seal
44644	Lock nut
44669	Spring, needle
44677	Pin, lower trigger
44735	Screw, fan control
44818	Spring, air piston
44826	Packing, air piston
44834	Air piston
44842	Bushing, needle packing
44859	Packing, needle
62810	Piston packing
64972	Air micrometer pin
68809	Spring, needle packing
74351	Gasket, air hose
79905	Needle packing service set
124164	Knob, fan control
124271	Air distribution ring
124750	Air cap seal ring 5-pk
124768	Air cap ring w/seal
125112	Snap ring (air cap ring)
125146	Knob, fluid control
125187	Air micrometer
125344	Fan control, O Ring, small
125351	Fan control
125377	Bushing, air piston
125492	Trigger
126037	Washer, tension spring
126276	Trigger service set
126292	Air piston service set (not shown)
127399	Air distribution ring 3-pk
131037	Fan control, O-Ring
133983	Air inlet fitting 1/4 BSP

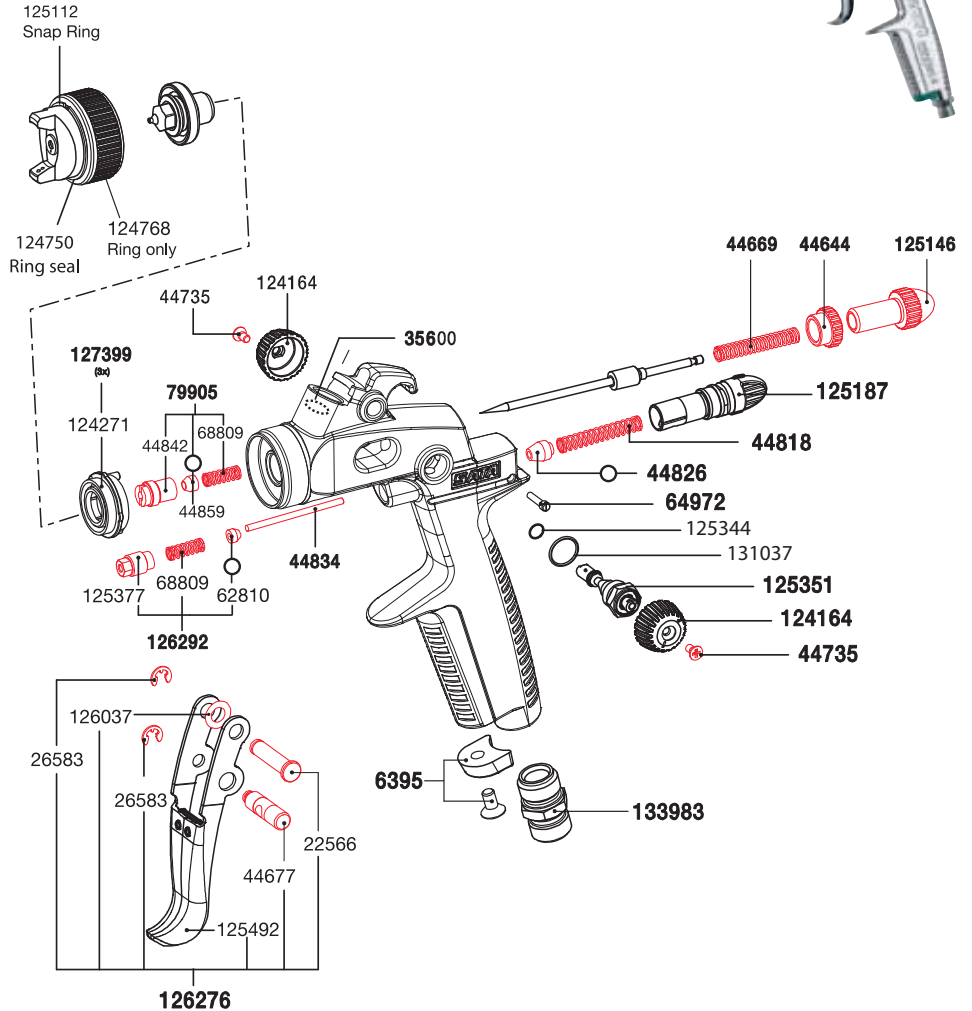

Part No./Descr.
125856
Tool kit
· Universal spanner
· Cleaning brush
· Allen wrench
· Extraction tool

Part No./Descr.
126284
Repair kit
○ 50658
Sealing kit

Technical modifications and printing errors reserved

SATAjet® KLC RP®/HVLP & P



Out of Production - Replacement parts available only until 2015, inquire for availability

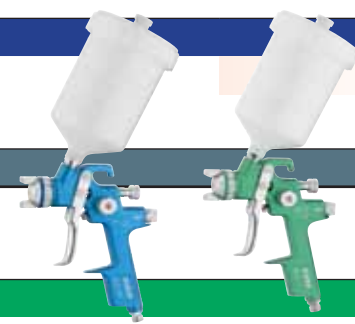

SATAjet KLC RP

Nozzle Set	1.3	1.6	1.6NA	1.8	2.0
Part No.	87973	NLA	88005	96768	87999

SATAjet KLC P

Nozzle Set	P
Part No.	88013

SATAjet KLC HVLP

Nozzle Set	1.4	1.7	1.9	2.1
Part No.	32748	32755	32771	33415

Part No./Descr.	
109	Air Inlet fitting
240	Packing, air piston (repair centre only)
422	Air piston packing
1503	Screw, fan control
3426	Circlip only, 1 each (repair centre only)
3624	Pin, air micrometer (repair centre only)
3699	Pin, lower trigger (repair centre only)
3749	Air piston packing holder
6486	Trigger service set
12591	Pin, upper trigger (repair centre only)
14605	Bushing, needle packing (repair centre only)
14993	Spring, needle packing (repair centre only)
15438	Kit, needle packing
17525	Lock spring
20396	Air distribution ring (1x)
27813	Spring, air piston (repair centre only)
17897	Spring, paint needle (repair centre only)
23275	Packing, needle (repair centre only)
29629	Air piston
53603	Air micrometer
54221	Fan control
55137	Trigger
62513	Air distribution insert
65557	Fan control knob
83758	Fluid control
133926	Kit, trigger sleeve
133934	Fan control seal 3-pk
133959	Spring set: 3 x #17152 & 3 x #10520
134601	Air distribution ring 3-pk

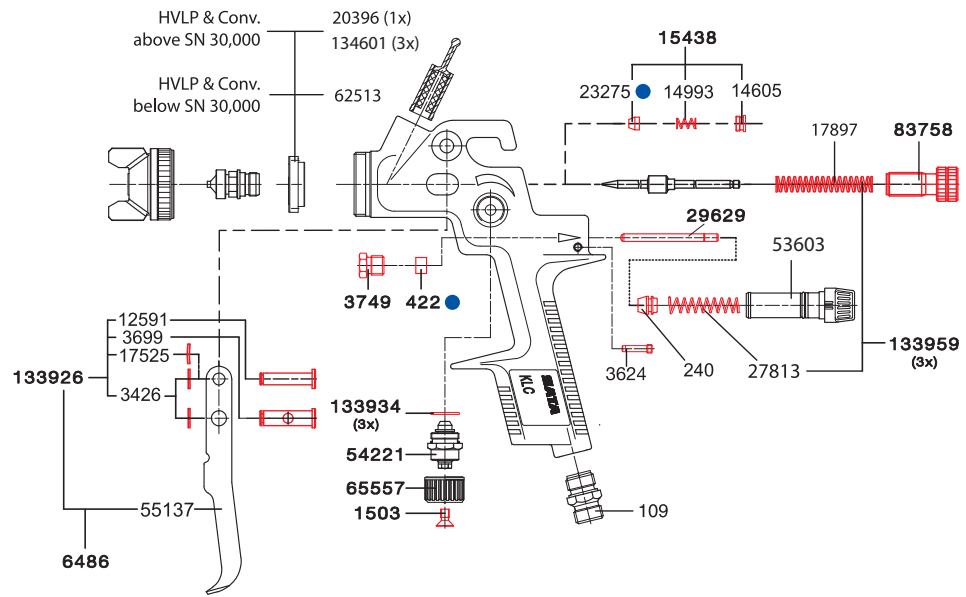

Part No./Descr.
9050
Tool kit
· Universal spanner
· Cleaning brush
· Allen/Trox wrench
· Allen wrench
· Extraction tool



Part No./Descr.
57620
Repair kit
· 54080
Packing set

SATAjet® B (SATAjet® GR)

Out of Production - Inquire for availability of replacement parts

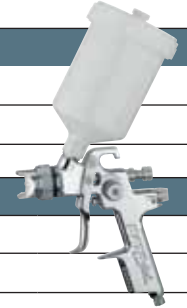

SATAjet B						
Nozzle Set	1.0	1.3 (MSB)	1.4	1.5	1.7	2.0
Part No.	4143	4127	3848	4119	4101	4093

SATAjet GR						
Nozzle Set	1.3 W	1.5 W	1.7 W	2.0 W	2.5 W	3.0 W
Part No.	31252	31898	31997	NLA	NLA	13011

Part No./Descr.	
422	Air piston packing
1503	Screw, fan control
2600	Service set for nozzle insert. Includes: nozzle insert, distribution plate & sealing ring
3566	Fluid inlet nipple
3657	Knob, fan control
3749	Air piston packing holder
3988	Sieve 10-pk
6445	Needle packing set
6486	Trigger service set
16162	Swivel joint
29629	Air piston
54221	Fan control
61416	Paint flow control screw cpl.. w/ counter nut
64766	Spacer ring
133926	Kit, trigger sleeve
133934	Packings 3-pk
133959	Spring set: 3 x #17152 & 3 x #10520
133967	Adjustment screws 3-pk
133983	Air connection piece G1/4a
133991	Air piston heads 3-pk of #240

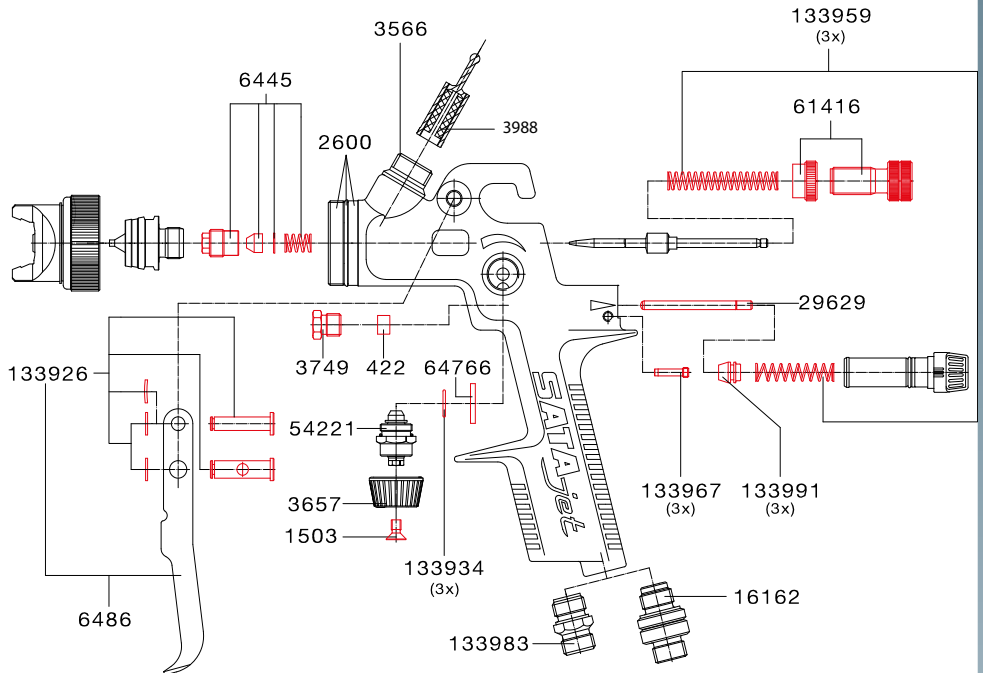

9654 Tool Kit	
901	Universal spanner wrench
3509	Cleaning brush
64543	Allen wrench 2mm
71431	Allen wrench 4mm
76307	Socket wrench



Part No./Descr.
69666
Repair kit from S/N 650000 on
9829
Packing set

Technical modifications and printing errors reserved

SATA® LM2000 B RP®/HVLP

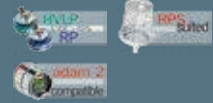

Out of Production - Inquire for availability of replacement parts

SATA LM2000 B RP

Nozzle Set	0.8	1.0	1.3	1.6	1.8	2.0	2.5	3.0	4.0	5.0
Part No.	26690	26716	26724	26732	26740	26757	26765	26781	26799	26807

SATA LM2000 B HVLP

Nozzle Set	1.4	1.7	1.9	2.1
Part No.	30106	30643	30742	31047

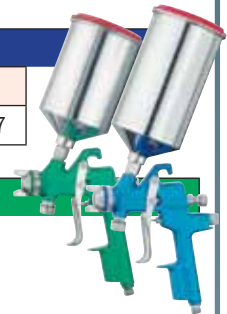

Part No./Descr.	
109	Air Inlet fitting
240	Packing, air piston (repair centre only)
422	Air piston packing
1503	Screw, fan control
2188	Fan control
3426	Circlip only, 1 each (repair centre only)
3624	Pin, air micrometer (repair centre only)
3699	Pin, lower trigger (repair centre only)
4648	Needle Spring
10520	12-pk Spring
12591	Pin, upper trigger (repair centre only)
16162	Swivel joint
17152	12-pk Spring
17525	Lock spring
21832	Paint needle packing spring
23275	Needle packing
27094	Air piston bushing
29629	Air piston
51839	12-pk needle packing spring
55939	Needle rod
56234	Slit needle, 4.0-5.0
61416	Fluid control
62513	Air distribution insert
65557	Fan control knob
86850	Needle packing bushing
89391	Trigger
94961	Air micrometer
133926	Kit, trigger sleeve
133959	Spring set: 3 x #17152 & 3 x #10520
133697	3-pk adjusting screw
133991	Packing, air piston pk of 3
134593	3-pk air distribution ring

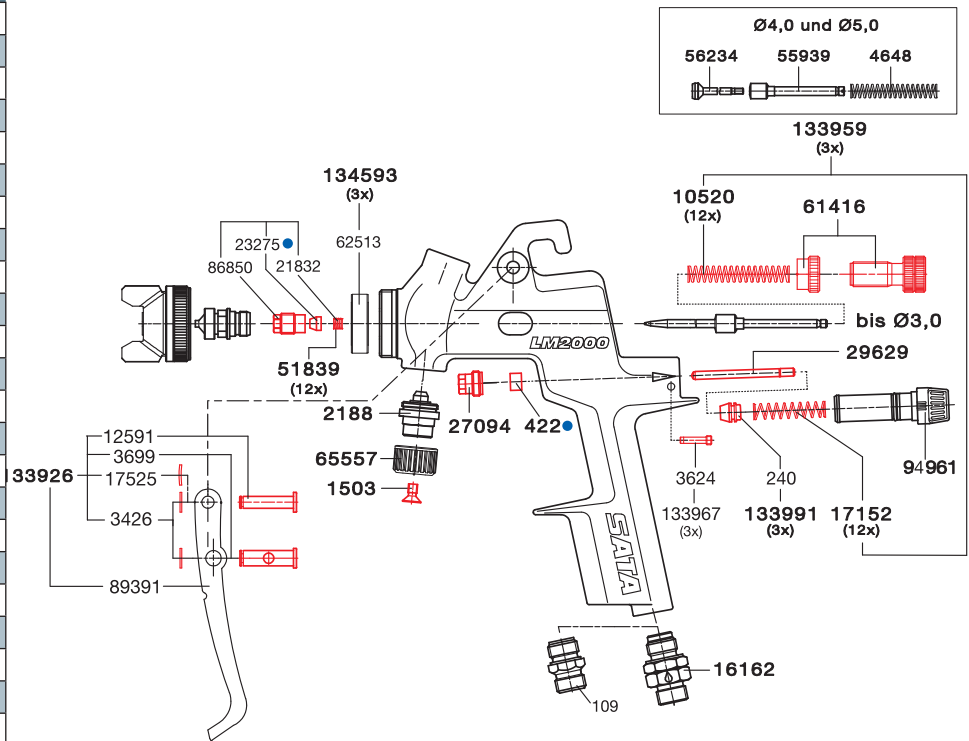

Part No./Descr.
9050
Tool kit
· Universal spanner
· Cleaning brush
· Allen/Trox wrench
· Allen wrench
· Extraction tool



Part No./Descr.
54957
Repair kit
· 84080
Packing set
125237
RPS adapter

SATA® LM2000 K RP®/HVL P SATA® LM2000 H RP®



Out of Production - Inquire for availability of replacement parts

SATA LM2000 K RP

Nozzle Set	0.8	1.0	1.3	1.6	1.8	2.0	2.5	3.0	4.0	5.0
Part No.	26690	26716	26724	26732	26740	26757	26765	26781	26799	26807

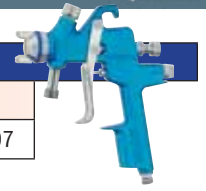

SATA LM2000 K RP Slit Nozzle Sets - NLA - OUT OF PRODUCTION

SATA LM2000 K HVL P

Nozzle Set	1.4	1.7	1.9	2.1
Part No.	30106	30643	30742	31047



SATA LM2000 H RP

Nozzle Set	1.6	1.8	2.0
Part No.	26732	26740	26757

Part No./Descr.	
109	Air Inlet fitting
422	Air piston packing
1503	Screw, fan control
3426	Circlip only, 1 each (repair centre only)
3624	Pin, air micrometer (repair centre only)
3699	Pin, lower trigger (repair centre only)
6213	Trigger service set
10520	12-pk Spring
12591	Pin, upper trigger (repair centre only)
16162	Swivel joint
17152	12-pk Spring
17525	Lock spring
17897	Paint needle spring (repair centre only)
21832	Needle packing spring
23275	Needle packing
26120	1.0 L siphon cup LM2000 H RP
27094	Air piston bushing
29629	Air piston
50542	Lock nut, fluid control
51839	12-pk needle packing spring
54221	Fan control
54668	Needle packing service set
61416	Fluid control
62513	Air distribution insert
65557	Fan control knob
69872	Fan control o-ring
83758	Fluid control
86850	Needle packing bushing
89391	Trigger
94961	Air micrometer
133926	Kit, trigger sleeve
133697	3-pk adjusting screw
133991	3-pack air piston head
134593	3-pk air distribution ring

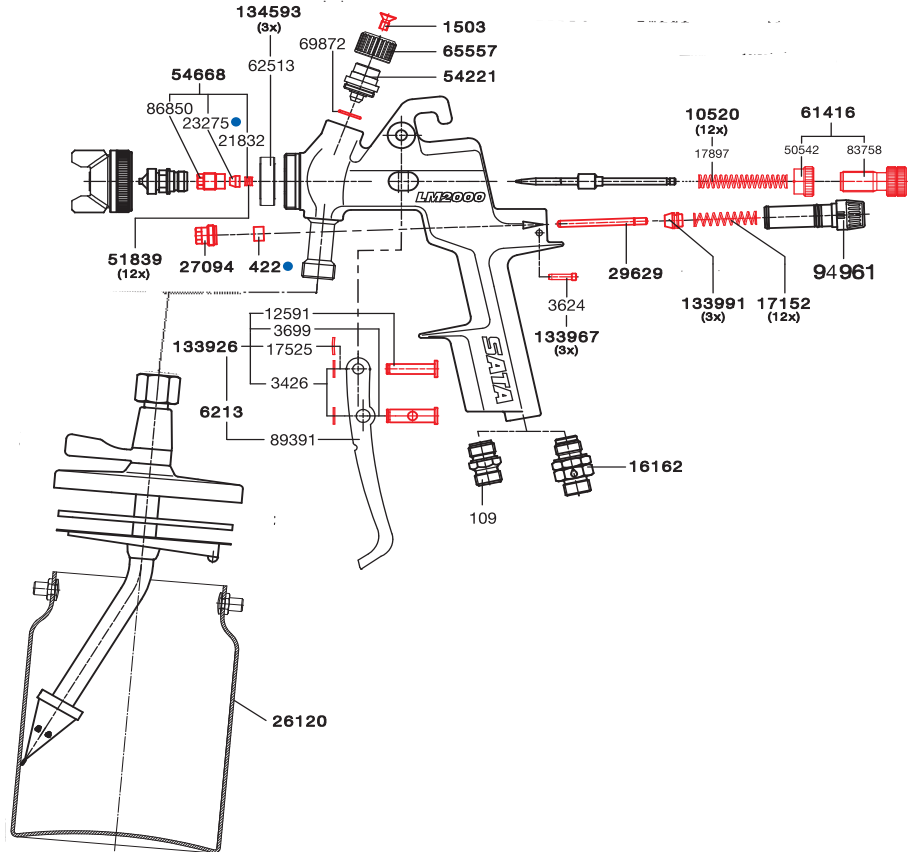

Part No./Descr.
9050
Tool kit
· Universal spanner
· Cleaning brush
· Allen/Trox wrench
· Allen wrench
· Extraction tool



Part No./Descr.
54957
Repair kit
· 54080
Packing set
188292
RPS adapter for siphon cup

Technical modifications and printing errors reserved

Spare Parts for Gravity feed SATA Spray Guns

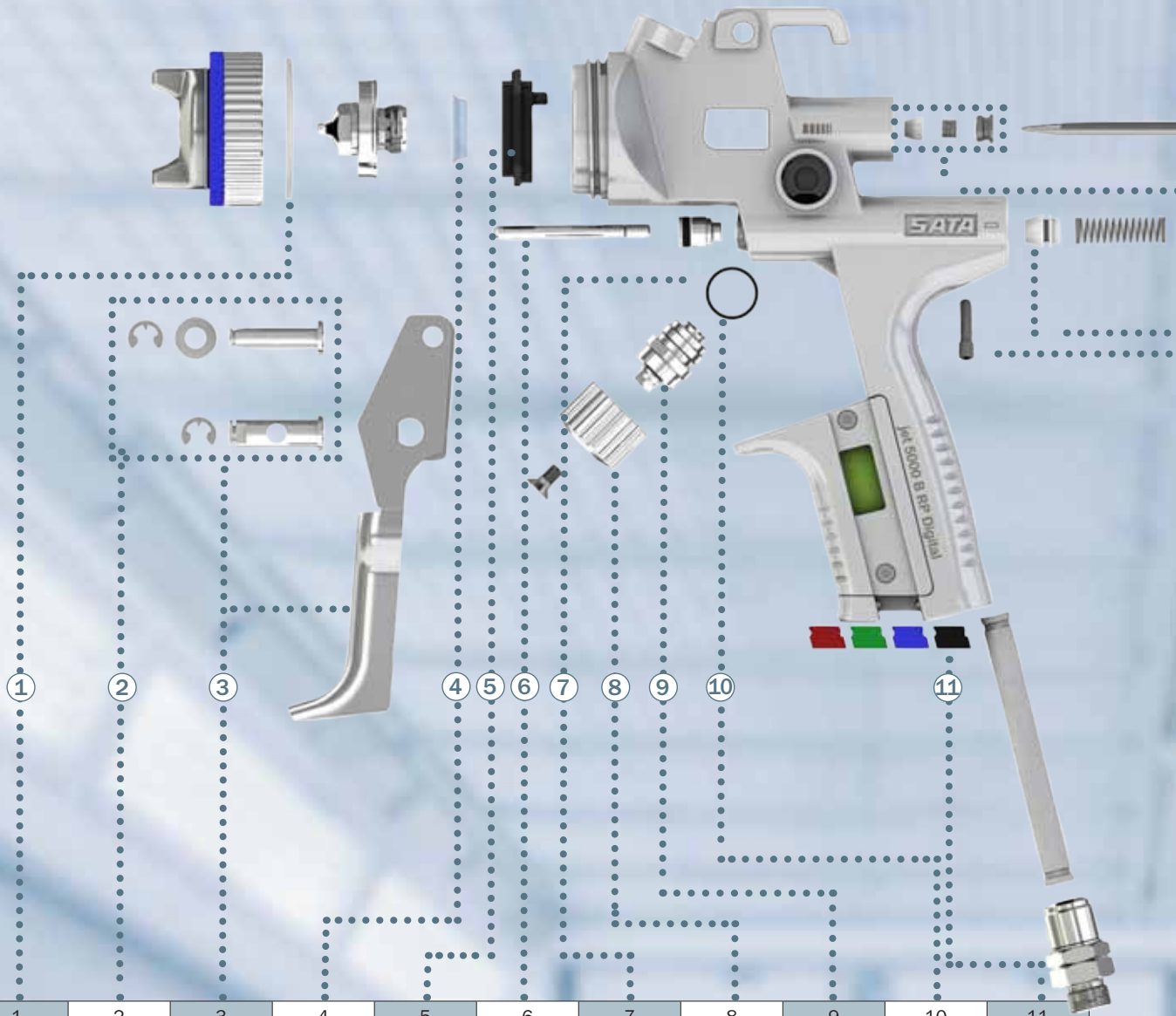

	1	2	3	4	5	6	7	8	9	10	11		
Gun Part	Seal Ring	Trigger sleeve kit	Trigger Kit	Seal Element (fluid tip)	Air distribution ring	Air piston rod	Seal retainer	Control knob	Spindle with seal	Spindle seal	CCS Clips		
Gun Type	3000 B	143834	133926	133850	-	97824			134031	89771		6395	
	4000 B	172429	166009	165977		165951	86843		166033	165944		165928	
	5000 B	211508	211458	211433		211425		133942	211482	213025	133934	211409	
	100 B				140582								
	1000 B		133926	130492		143230	91959		140574	89771		6395	
	minijet 3000 B		-	126276	-	127399	44834	126292	124164	125351	-		
	minijet 4400 B	200907	199463	198473	199455	197467	195408	199414	200162	198549	199471	197418	

Spare Parts for Gravity feed SATA Spray Guns

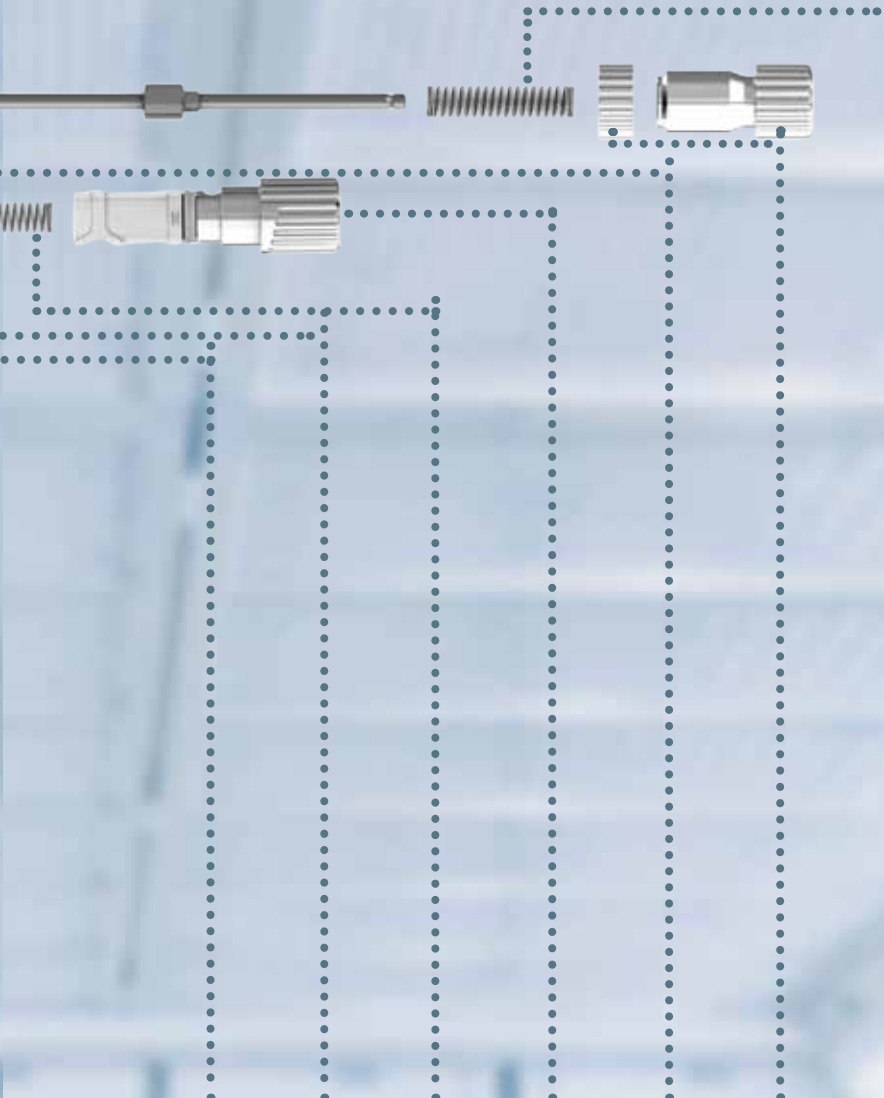

Air Connection Piece					
Gun Type	Standard Guns	Standard Swivel Joint	Digital Guns	Digital Swivel Joint	Seal Retainer w/ Sleeve
3000 B	134098	19745	133975	203414	133876
4000 B			166116	203422	165985
5000 B			211490	211516--	211441
100 B	133983	16162	-	-	-
1000 B			-	-	-
minijet 3000 B			-	-	-
minijet 4400 B			-	-	-

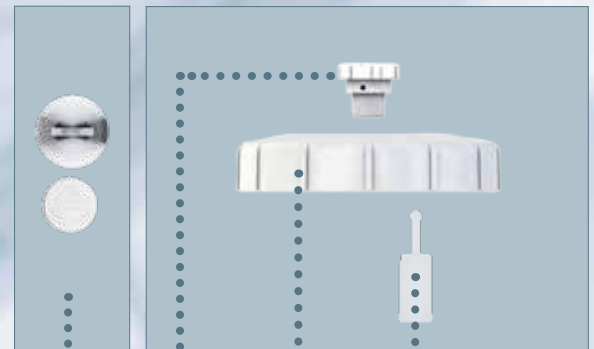

12	13	14	15	16	17	18	19	20	21	22	Gun Part	Gun Type
Locking Screw	Air piston head	Pressure spring, air piston	Air micrometer	Paint needle packing	Material flow control	Pressure spring paint needle	Battery Kit	Anti-drip device	Screw on lid	Strainer, 300 µ		
133967	133991	133595	134015	15438	134023	133959	133884	1826	49395 0.61 PVC cup only	3988	3000 B	3000 B
			166017		166025		165993				4000 B	
211391			211466		211474		213769				5000 B	
133967			139964		139188		-				100 B	
64972	44826	201467	125187	79905	125146 (counter nut sold separately)	201467	-	95489	95448 125 ccm PVC cup	-	1000 B	minijet 3000 B
199430	199448		198523	199414	199403		-	1197558	199075 125 ccm PVC cup	3988	-	minijet 4400 B

Material and air connection SATAjet® 3000 K, 1000 K

Part No./Desc.	
6981	Quick coupling nipple G 1/4 female thread, packing unit:5
13623	SATA quick coupling 100.14 G 1/4 male thread
38265	Strainer for SATA pressure fed spray guns G3/8i - G3/8a. 60 mesh, WA-version
91140	Material coupling G 3/8 a for SATA pressure fed spray guns with plug-in nipple G3/8i
91157	Material coupling with plug-in nipple and material strainer 60 mesh, G3/8i - G3/8a for SATA pressure fed spray guns
92031	Paint pipe for SATA pressure fed spray guns G3/8i - G3/8a version for waterborne material

Spare sieves

Part No./Desc.	
12260	4-pack sieves, 60 mesh for SATA paint strainers
12278	4-pack sieves, 100 mesh for SATA paint strainers

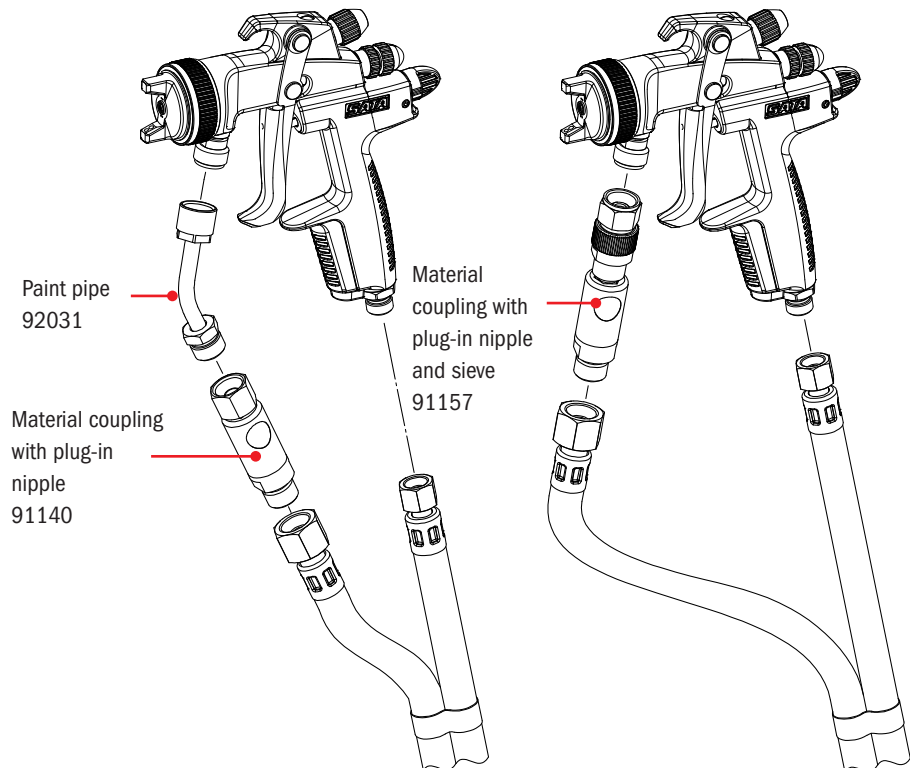
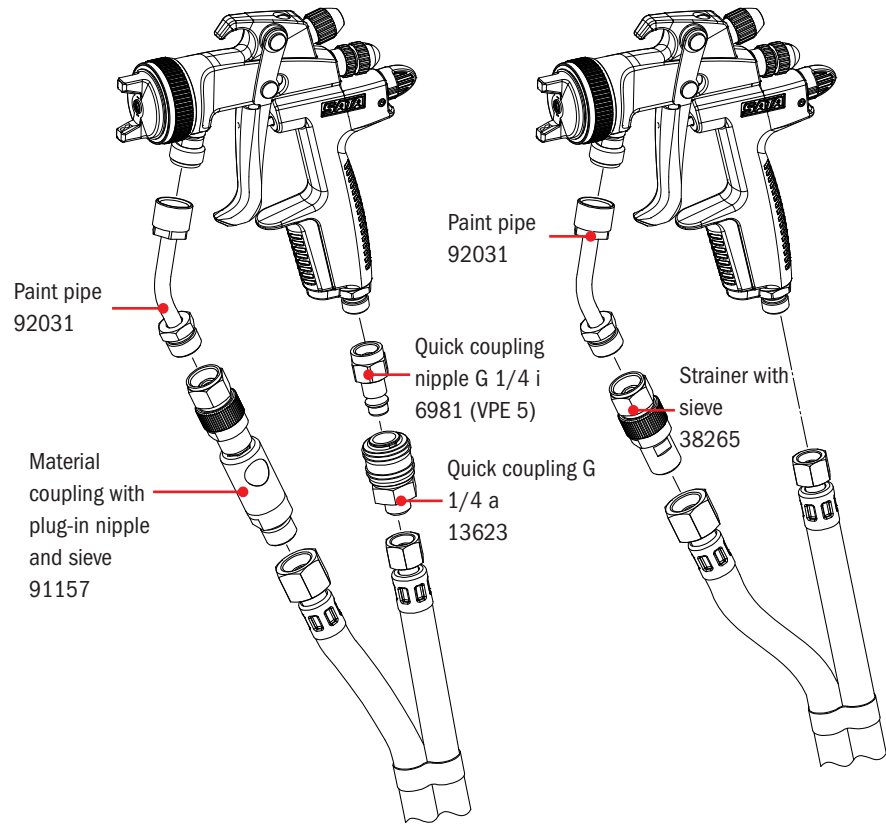

Material and air connection SATAminijet® 1000 K

Part No./Desc.
187419 Paint pipe, SS, G 1/4 - G 1/4
199018 Paint pipe, SS, G 1/4 - G 3/8
191551 Adapter, G 1/4 male x G 3/8 male

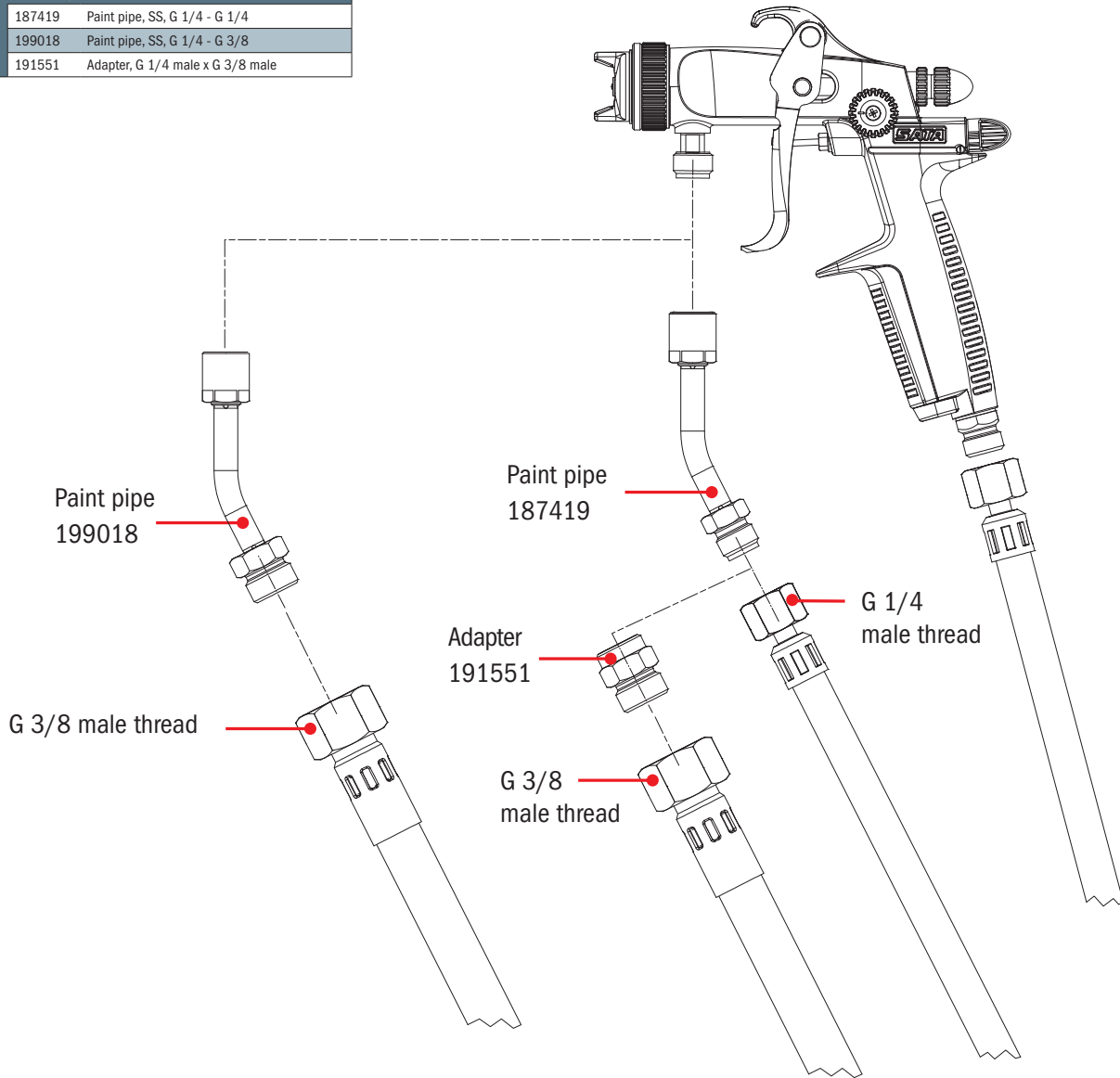





Hoses page 147

Accessories SATAjet® 3000 K, SATAjet® 1000 B/K,



**All Nozzle Extensions & components are special order items and not returnable.
Please allow several weeks for delivery.**

Extensions SATAjet 1000 K RP

154435	20 cm - Straight Extension SATAjet 1000 K RP 1.5 round/flat fan	
154443	30 cm - Straight Extension SATAjet 1000 K RP 1.5 round/flat fan	
154450	40 cm - Straight Extension SATAjet 1000 K RP 1.5 round/flat fan	
154476	20 cm - 45° Diagonal spray extension SATAjet 1000 K RP 1.6	
154484	30 cm - 45° Diagonal spray extension SATAjet 1000 K RP 1.6	
154492	40 cm - 45° Diagonal spray extension SATAjet 1000 K RP 1.6	
154518	20 cm - 360° Internal mixing extension SATAjet 1000 K RP 1.6	
154526	30 cm - 360° Internal mixing extension SATAjet 1000 K RP 1.6	
154534	40 cm - 360° Internal mixing extension SATAjet 1000 K RP 1.6	
154559	20 cm - 90° Angular head extension SATAjet 1000 K RP 1.6	
154567	30 cm - 90° Angular head extension SATAjet 1000 K RP 1.6	
154575	40 cm - 90° Angular head extension SATAjet 1000 K RP 1.6	



Extensions in other lengths are available upon request

Extensions SATAjet 1000 A RP





164293	20 cm - 45° Diagonal spray extension SATAjet 1000 K RP 1.6	
164301	30 cm - 45° Diagonal spray extension SATAjet 1000 K RP 1.6	
Call	40 cm - 45° Diagonal spray extension SATAjet 1000 K RP 1.6	
164277	20 cm - 360° Internal mixing extension SATAjet 1000 K RP 1.6	
164285	30 cm - 360° Internal mixing extension SATAjet 1000 K RP 1.6	
Call	40 cm - 360° Internal mixing extension SATAjet 1000 K RP 1.6	

Extensions in other lengths are available upon request

Accessories for SATA pressure fed spray guns

92031	Paint pipe for full sized SATA pressure fed spray guns G3/8 i - G3/8	
187419	Paint pipe, for minijet SATA pressure fed spray guns G1/4 i - G3/8	
199018	Paint pipe, for minijet SATA pressure fed spray guns G1/4 i - G1/4	
38265	Strainer for SATA pressure fed spray guns G3/8 i, 60 mesh, WA version	
187690	Strainer for SATA minijet pressure fed spray guns G 1/4 i, 60 mesh, WA version	

Additional accessories for SATA pressure fed spray guns

12260	4-pk sieves, 60 mesh for SATA paint strainer	
12278	4-pk sieves, 100 mesh for SATA paint strainer	
74856	SATA strainer kit, consisting of 4 sieves 200 mesh, 2 strainer holders and 1 screw for SATA paint strainer	
91108	QC nipple	
91140	Material coupling G 3/8 a for SATA pressure fed spray guns with plug-in nipple G3/8i	
91157	Material coupling with plug-in nipple and material strainer 60 mesh, G3/8i - G3/8a for SATA pressure fed spray guns	

Parts nozzle extensions

**All Nozzle Extensions & components are special order items and not returnable.
Please allow several weeks for delivery.**

Components for SATAjet 1000 RP - Straight Nozzle Extension

SATAjet 1000 K Straight Nozzle Extension	
Part No.	Description
140582	Seal, fluid tip, pk of 5
154914	Sealing ring

Ext. No.	Length	Pos 10	Pos 20	Pos 30	Pos 40	Pos 50
154435	20cm	154880	139071	139477	154716	154807
154443	30cm	154896	139071	139477	154724	154815
154450	40cm	154906	139071	139477	154732	154823

SATAjet 1000 K & A 45° Nozzle Extension	
Part No.	Description
43760	Tightening ring
140582	Seal, fluid tip, pk of 5
155226	Flange sleeve

SATAjet 1000 K						
Ext. No.	Length	Pos 10	Pos 20	Pos 30	Pos 40	Pos 50
154476	20cm	155184	24158	24141	24182	155267
154484	30cm	155192	24158	24141	4432	155275
154492	40cm	155200	24158	24141	4531	155283

Automatic spray guns						
Ext. No.	Length	Pos 10	Pos 20	Pos 30	Pos 40	Pos 50
164293	20cm	155184	24158	24141	24182	46490
164301	30cm	155192	24158	24141	4432	47100
	40cm	155200	24158	24141	4531	47688

SATAjet 1000 K 90° Nozzle Extension	
Part No.	Description
30932	O-ring
140582	Seal, fluid tip, pk of 5
154955	Angular head
155099	Fluid tip 3.0

Ext. No.	Length	Pos 10	Pos 20	Pos 30	Pos 40	Pos 50
154559	20cm	155036	139071	139477	154971	155101
154567	30cm	155044	139071	139477	154989	155119
154575	40cm	155051	139071	139477	154997	155127

SATAjet 1000 K & A 360° Nozzle Extension	
Part No.	Description
30585	Plate-shaped internal mixing nozzle
30593	Nozzle screw
43760	Tightening ring
140582	Seal, fluid tip, pk of 5
155226	Flange sleeve

SATAjet 1000 K						
Ext. No.	Length	Pos 10	Pos 20	Pos 40	Pos 50	
154518	20cm	155184	24158	24182	155267	
154526	30cm	155192	24158	4432	155275	
154534	40cm	155200	24158	4531	155283	

Automatic spray guns						
Ext. No.	Length	Pos 10	Pos 20	Pos 40	Pos 50	
164277	20cm	155184	24158	24182	46490	
164285	30cm	155192	24158	4432	47100	
	40cm	155200	24158	4531	47688	

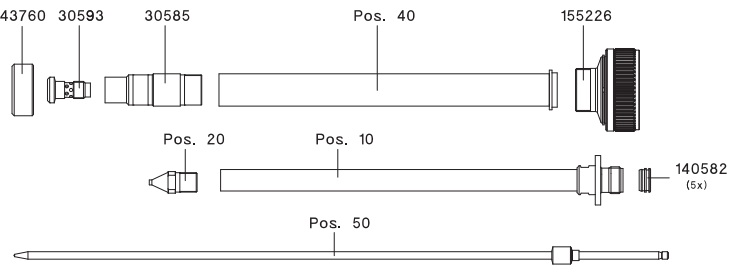
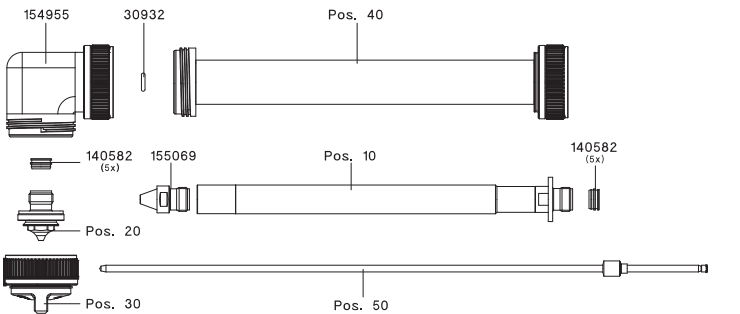
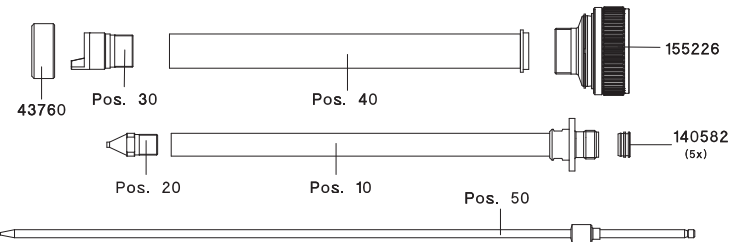
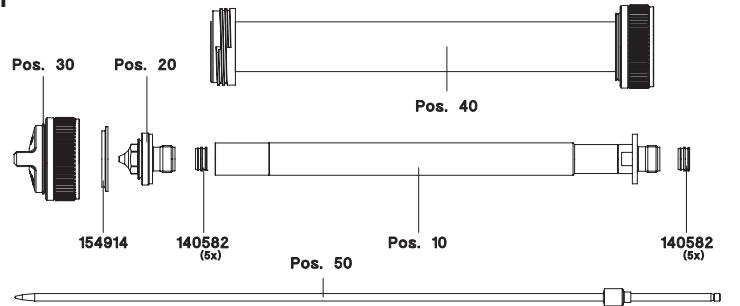

Technical modifications and printing errors reserved







Accessories for Spray Guns

SATA adam 2 - Accurate pressure control



The digital pressure gauge SATA adam 2 allows the exact adjustment of the spray pressure on paint spray guns with an accuracy of +/- 1 psi. Permanent spray pressure control during painting significantly contributes to perfect color matching and high quality finishes preventing costly reworks due to incorrect pressure setting.

All SATA paint spray guns with an integrated air micrometer can now be upgraded with the SATA adam 2. The assembly is very simple and quick - the standard air micrometer is replaced by the retrofit SATA adam 2 with just a few easy steps.







211557	SATA adam 2, 5000 complete Consisting of two separate components: mounting dock, to replace the air micrometer and display (psi) display for SATAjet 5000 B spray guns only	
211565	SATA adam 2, 5000 dock only Mounting dock for the SATA adam 2 on the SATAjet 50000 B spray guns only. Replaces the standard air micrometer included with gun, the integrated seal provides full pressure setting functionality even when the display has been removed. Comes with protective cover when display is not mounted.	
160853	SATA adam 2, complete Consisting of two separate components: mounting dock, to replace the air micrometer and display (psi) display - for all SATA standard size spray guns, <u>except</u> for the SATAjet 5000 B	
160788	SATA adam 2, dock only Mounting dock for the SATA adam 2 on full sized SATA spray guns (except the SATAjet 50000 B). Replaces the standard air micrometer included with gun, the integrated seal provides full pressure setting functionality even when the display has been removed. Comes with protective cover when display is not mounted.	
160887	SATA adam 2 mini, complete Consisting of two separate components: mounting dock, to replace the air micrometer and display (psi) display - for all SATAMinijet sized spray guns.	
160861	SATA adam 2, mini dock only Mounting dock for the SATA adam 2 on SATAMinijet sized spray guns. Replaces the standard air micrometer included with gun, the integrated seal provides full pressure setting functionality even when the display has been removed. Comes with protective cover when display is not mounted.	
160697	SATA adam 2, display only The digital readout which contains all electronic components. As the pressure is set by turning the setting wings on the docking base only, the digital display always remains in the upright position ensuring perfect pressure reading at all times. For increased safety during gun cleaning in gun washing machines, a simple, reliable click-in mechanism quickly releases the SATA adam 2 display from the dock. This mechanism also allows using the SATA adam 2 display on different SATA spray guns equipped with a docking base and the adam 2U.	
160739	SATA adam 2 battery set	

SATA adam 2 U (digital pressure gauge)

195222	SATA adam 2 U, complete Consisting of two separate components: dock and digital (psi) gauge. This system, complete with shut off valve, fits at the air inlet of any shop tool for precise measurement of air pressure.	
195230	SATA adam 2 U, dock only Complete Air micrometer with shut off valve and mounting plate for SATA adam 2 digital gauges. Air in connection: G 1/4 male, air out connection G 1/4 female	
195925	SATA adam 2 U conversion dock only To convert the analog gauge on a #27771 to a digital adam 2 U or analog gauge on a SATA filter, 400 series. G 1/8 male threads, to retrofit a digital gauge to analogue equipment.	

Accessories for Spray Guns

Air Micrometer and Pressure Gauges		
27771	<p>SATA Air Micrometer with Gauge</p> <p>This high quality air micrometer indicates air pressure settings at the spray gun air inlet. The gauge bezel has a green color coded pressure range for correct adjustment of SATA HVLV guns and blue for SATA RP (reduced pressure) guns. The SATA air micrometer with gauge housing is anodized black and adjustable from 0 - 145 psi.</p>	
123513	Gauge only (not illustrated)	
4002	<p>SATA In-Line Hose Pressure Gauge</p> <p>High-volume in-line pressure gauge with unrestricted airflow to the spray gun (non-adjustable). HVLV and RP color-coded pressure gauge face with a high flow coupler and nipple.</p>	
9860	<p>SATA air micrometer without gauge</p> <p>It also works well with spray guns without the built-in air micrometer feature or when air pressure is not critical. Rugged metal black anodized housing. Connects to 1/4 BSP air inlet fitting.</p>	
43786	<p>SATA line pressure gauge</p> <p>It also works well with spray guns without the built-in air micrometer feature or when air pressure is not critical. Rugged metal black anodized housing. Connects to 1/4 BSP</p>	

Spare Parts SATA® adam 2

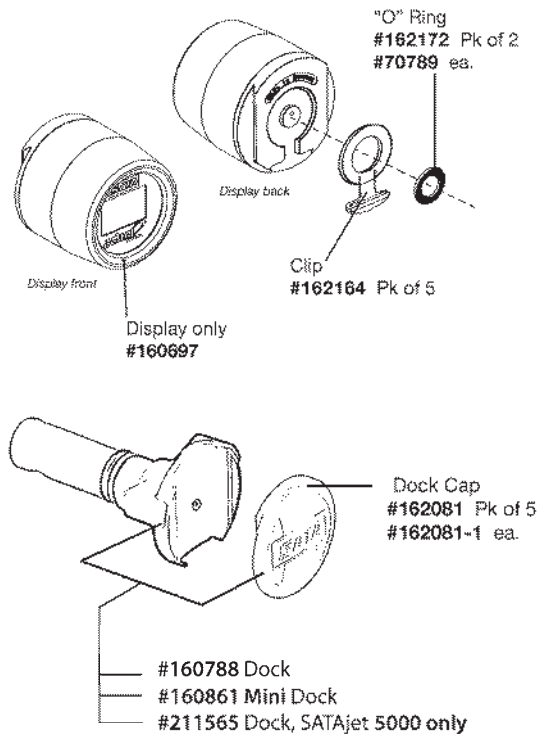









Battery replacement kit
Part No. 160739

Accessories for Spray Guns



Pressure measurement and adjustment		
Air connection		
13656	SATA HVLP female nipple G 1/4 female thread (use 6981 for 5-pk)	
53942	SATA HVLP male nipple G 1/4 male thread	
13599	SATA HVLP female QC G 1/4 female thread	
13623	SATA HVLP male QC G 1/4 male thread	
99895	Universal swivel fitting - flexible connection nipple G 1/4	
Spray Gun Holders		
192195	SATA spray gun and hose holder	
9886	SATA gravity gun holder	
40188	SATA bench mounted gun holder	
69328	Spray gun stand, complete, for SATAminijet 3000 B HVLP and SATAjet 20 B Can be used for gravity or side cups	
9898-3 9898-6	3 gun wall mount, for gravity fed spray guns (shown) 6 gun wall mount (2 x 9898-3), for gravity fed spray guns	
Cleaning and maintenance		
60095	SATAclean, 3 gun soaking tray	
60111	Plug-set (3-pieces) for SATAclean	
162628	SATA care set, spray gun care bag with cleaning utensils and spray gun grease. Scope of supply: 1x Large cleaning brush, 5x medium cleaning brush, 5x double ended cleaning brush, 12x nozzle cleaning needles, 1x high performance SATA grease (100 ml)	
48173	100 g tube SATA high performance grease for spray guns, silicone and acid free	
3988	10-pk paint strainer for SATA reusable cups	
9894 62174	SATA nozzle cleaning needles, pk of 12 SATA nozzle cleaning needles, pk of 36	
64030	Cleaning set: 2x cleaning brushes & 12x nozzle cleaning needles	

Accessories for Spray Guns

Cleaning and maintenance		
6007	Cleaning brushes, pk of 10 11 cm/4.5" w/ black bristles and soft tip to protect gun body	
9209	Small cleaning brushes, pack of 10 7.5 cm/3" double ended fine/extra fine white bristles for air cap horns	
158840	Cleaning brushes, pack of 5 18 cm/7" tooth-brush style for heavy cleaning	
29280	Large cleaning brush for Siphon cups and pick up tubes, pack of 10	
64035	Spray gun maintenance kit: 13 x various sized SATA cleaning brushes, 2 x SATA cleaning broaches, 1 x gun lube (1/2 oz)	
64036	Air brush cleaning kit, includes; 5x mini brush set, 1x plastic handled brush, 2x double ended brushes, 2x cleaning brushes w/handle, 2x cleaning broches, 2x large brushes, 1x EZ airbrush cleaner, 1x airbrush lube oil	
48173	SATA gun grease	
9845	SATA viscosity cup DIN 4, machined from solid aluminum See page 168 for conversion chart	
9852	SATA viscosity cup DIN 4, extruded aluminum See page 168 for conversion chart	
Quality control		
7096	SATA Air Check Set Compressed air testing device. Simply connect and allow air flow for 15 minutes or longer. Test paper traps dirt, oil and in-line contamination. Complete with test paper, tweezers, magnifying glass and exam light all in a compact carrying case.	
	Air check test paper	
7666-10	Test paper, pack of 10	
7666-50	Test paper, pack of 50	
7666-100	Test paper, pack of 100	
156299	SATA air tester, use to determine contaminates in airline	
161596	SATA cert, with archive, spray pattern block, single sheet holder and distance marker	
161646	Spray pattern blocks each w/ 25 sheets for SATA cert	
16166	Distance marker for SATA cert	

Continued on page 66

Accessories for Spray Guns

Cleaning and maintenance		
Other accessories		
165506	Air cap protectors (red) for SATAjet 3000 B, K, SATAjet 2000, all K3's and LP90, 5 pack	
165514	Air cap protectors (red) for SATAjet 100 B and SATAjet 1000 B, SATAjet 4000 & 5000 B, 5 pack	
165522	Air cap protectors (red) for SATAMinijet 3000, SATAMinijet 1000 K, 5 pack	
139444	Air cap protector (black) for UV materials, (not shown), SATAjet 2000, 3000 & K3, 5 pack	
203331	Air cap protectors (red) for SATAMinijet 4400 B, 5 pack	
TP-MINI TP-MINI5	SATAMinijet, minijet 2, minijet 3, each SATAMinijet, minijet 2, minijet 3, pack of 5	
TP-INLET TP-INLET5	Inlet protector, each Inlet protector, pack of 5	

Cleaning & Maintenance

Intermediate Cleaning

Intermediate cleaning with SATA cleanRCS

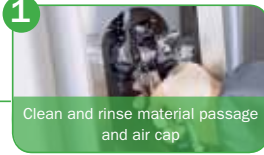

1 Clean and rinse material passage and air cap



2 Blow dry spray gun and material passage

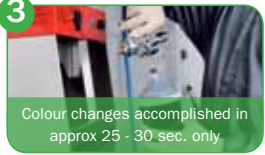

3 Colour changes accomplished in approx 25 - 30 sec. only

Automatic gun cleaning

Cleaning with gun washing machine SATA multi clean 2

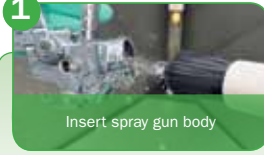

1 Insert spray gun body



2 Connect air connection to air inlet

Please ensure that the spray gun is always placed in the correct position inside the washing chamber of self-contained washing machines. Make sure that no cleaning agent penetrated the air passages of the spray gun.

Important Note

It is **essential** to observe the **pH value** of your cleaning agent!

The pH value should be ranging between **6 - 8!**

Cleaning Accessories



Part No. 158840
5 cleaning brushes, large for cleaning the outside of the gun body



Part No. 6007
10 cleaning brushes, medium size for fluid tip and material passages of gun



Part No. 9209
10 double-sided cleaning brushes for cleaning air caps and fluid tips



Part No. 9894
12 nozzle cleaning needles for cleaning front apertures of air cap and fluid tip



Part No. 48173
High performance grease, 100 ml, silicone and acid free for all moving parts of the gun



Part No. 64030
Cleaning kit consisting of 2 cleaning brushes and 12 cleaning needles



Part No. 162628
Includes:
1x Cleaning brush, large ①
5x Cleaning brushes, medium ②
5x Cleaning brushes, double-sided ③
12x Nozzle cleaning needles ④
1x high performance grease, 100 ml ⑤

Please make sure that all brushes being used have no protruding metal wires as these may damage the spray gun. Please exclusively use recommended tools for cleaning only.

We recommend leaving the spray gun connected to the air circuit with reduced pressure even for manual cleaning. Make sure that cleaning agent never enters the air passages of the spray gun.

Disassembly and manual cleaning

Disassembly of nozzle set

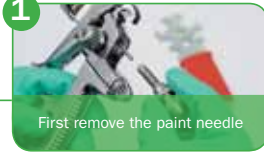

1 First remove the paint needle



2 Then disassemble the air cap

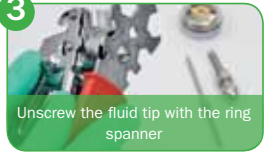

3 Unscrew the fluid tip with the ring spanner

Cleaning and drying of the spray gun...

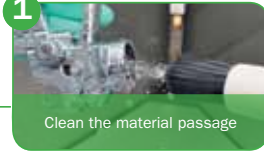

1 Clean the material passage

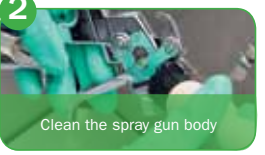

2 Clean the spray gun body

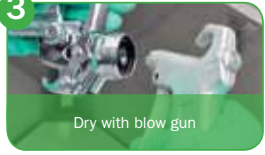

3 Dry with blow gun

... and the nozzle set



1



2



3



4



5



6

Assembly and Maintenance

Assembly and Maintenance

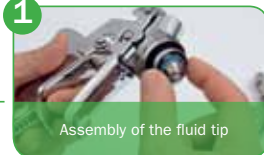

1 Assembly of the fluid tip



2 Hand-tighten fluid tip with the universal spanner

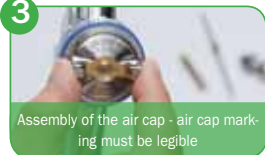

3 Assembly of the air cap - air cap marking must be legible

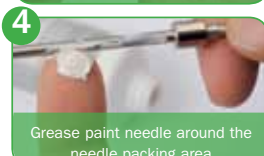

4 Grease paint needle around the needle packing area



5 Insert paint needle

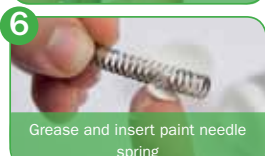

6 Grease and insert paint needle spring

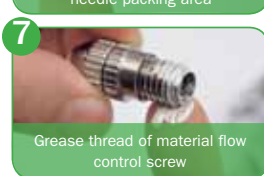

7 Grease thread of material flow control screw

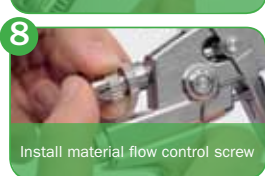

8 Install material flow control screw

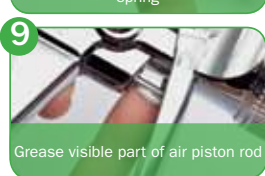

9 Grease visible part of air piston rod

Final blow dry before painting



Before painting, connect the air hose and blow air to be sure all passages are dry. With air connected and trigger pulled, move the air micrometer and fan control knobs back and forth to force air in and out of all air passages to empty them completely of solvent or water. Put gun away dry, do not soak the air cap.

Viscosity Cup Conversion Chart - SATA DIN 4

SATA 4	POISE	CENIPOISE	DUPONT PARLIN 7	DUPONT PARLIN 10	FISHER 1	FISHER 2	FORD CUP 3	FORD CUP 4	KREBS UNITS KU	SAYBOLT UNIVERSAL	ZAHN 1	ZAHN 2	ZAHN 3	ZAHN 4	ZAHN 5	SATA 4
9	0,1	10	27	11	20			5		50	30	16				9
11	0,15	15	30	12	25			8		80	34	17				11
12	0,2	20	32	13	30	15	12	10		100	37	18				12
15	0,25	25	37	14	35	17	15	12		130	41	19				15
17	0,3	30	43	15	39	18	19	15		160	44	20				17
18	0,4	40	50	16	50	21	25	17		210	52	22				18
20	0,5	50	57	17		24	29	19	30	260	60	24				20
22	0,6	60	64	18		29	33	21	33	320	68	27				22
23	0,7	70		20		33	36	23	35	370		30				23
24	0,8	80		22		39	41	26	37	430	34					24
28	0,9	90		23		44	45	29	38	480		37	10			28
30	1,0	100		25		50	50	31	40	530		41	12	10		30
32	1,2	120		30		62	58	36	43	580		49	14	11		32
39	1,4	140		32			66	41	46	690		58	16	13		39
42	1,6	160		37				45	48	790		66	18	14		42
46	1,8	180		41				51	50	900		74	20	16		46
50	2,0	200		45				56	52	1000		82	23	17	10	50
55	2,2	220						61	54	1100			25	18	11	55
59	2,4	240						67	56	1200			20	12	12	59
64	2,6	260						72	58	1280			30	21	13	64
67	2,8	280						76	59	1380			32	22	14	67
70	3,0	300						83	60	1475			34	24	15	70
74	3,2	320								1530			36	25	16	74
79	3,4	340								1630			39	26	17	79
83	3,6	360							62	1730			41	28	18	83
86	3,8	380								1850			43	29	19	86
89	4,0	400							64	1950			46	30	20	89
94	4,2	420								2050			48	32	21	94
100	4,4	440								2160			50	33	22	100
105	4,6	460							66	2270			52	34	23	105
110	4,8	480								2380			54	36	24	110
122	5,0	500								2480			57	37	25	122
131	5,5	550								2660			63	40	27	131
150	6	600								2900			68	44	30	150
172	7	700								3375				51	35	172
193	8	800								3880				58	40	193
274	9	900								4300				64	45	274
	10	1000								4600					49	
	11	1100								5200					66	

General guidelines for gravity guns using a 4 mm or a DIN 4 viscosity cup

Use smaller nozzle sizes for pressure fed and larger for siphon fed guns.

General guidelines for nozzle sizes

- 1.2 for water borne
- 1.3 for basecoat, some clears with low VOC on HVLP
- 1.4 for clearcoat, single stage, surfacer, sealer, epoxy, waterborne, wash and etch primer
- 1.5 for clearcoat, single stage
- 1.6 for primer
- 1.7 for primer, filler
- 1.8 for primer, filler
- 1.9 for filler, high build
- 2.0 for filler, high build
- 2.5 for polyester



SATA Viscosity Cup

Using a viscosity cup will ensure consistent measuring of material viscosity for selecting the right nozzle size. 4 mm or DIN 4

Extruded Aluminium

Part No. 9852

Turned Aluminium

Part No. 9845



How to use a SATA 4 viscosity cup

The flow time measured with the SATA 4 mm viscosity cup can be compared with the times of a DIN 4 cup (German Industrial Standard). The SATA 4 viscosity cup, part number 9852 is a 100 ml container with a 4 mm orifice. To measure material viscosity, dip the cup in the material, using a stopwatch or second hand on a watch. Count the time until material flow stops at the cup. The clearance time is the DIN viscosity expressed in seconds. Determining the viscosity makes nozzle selection easier. Also check paint company application charts for nozzle sizes.

Automatic & Robotic Spray Guns







Selection guide for Auto and ROB spray guns

		SATAjet® 3000 A		SATAjet® 3000 ROB		SATAjet® 1000 A		SATAMinijet® 1000 A	
									
PERFORMANCE FEATURES	Atomization technology (RP/HVLP)	HVLP	RP	HVLP	RP	RP	HVLP	RP	
	Internal control	■	■	--	--	■	■	■	
	External control	--	--	■	■	--	--	--	
	*Spray fan width in cm	22 - 34	22 - 40	31 - 33	22 - 40	24 - 37	16 - 27	13 - 27	
	* Material flow in g/min	150 - 700	100 - 900	300 - 400	400 - 500	150 - 1000	60 - 170	60 - 250	
	** Air consumption in l/min at 2.5 bar	450	400	450	450	440	170	195	
	Material circulation	■	■	■	■	■	■	■	
	Optional: Extensions	--	--	--	--	■	--	--	
FIELDS OF APPLICATION	Externally controlled robotic systems	--	--	■	■	--	--	--	
	Robotic painting systems with adjustment of the spray parameters on the spray gun	■	■	--	--	■	■	■	
	Marking applications, component marking	--	--	--	--	--	--	--	
TECHNICAL DATA	Spray gun weight in g	Standard: 780 Stainless steel: 990		Standard: 490 Stainless steel: 690		Standard: 780 Stainless steel: 990		Standard: -- Stainless steel: 915	
	Spray gun length in mm	147		127		147		147	
	Width x height in mm	45 x 45		45 x 45		45 x 45		45 x 45	
	Air cap fixation	45°		45°		45°		--	
	Available nozzle sizes	HVLP: 0.5; 0.8; 1.0; 1.2; 1.6; 2.0 RP: 0.5; 0.8; 1.1; 1.3; 1.5; 2.0				RP: 0.8; 1.1; 1.3; 1.5; 2.0; 3.0		HVLP: 0.3; 0.5; 0.8; 1.0; 1.2 RP: 0.3; 0.5; 0.8; 1.0; 1.2	
	Standard version Anodized aluminium	■		■		■		--	
	Stainless steel version	■		■		■		■	
	Connection thread Material inlet/-outlet, control air, atomization air	G 1/4 Female thread		G 1/4 Female thread		G 1/4 Female thread		G 1/4 Female thread	
	Optional: Quick change adapter	A		ROB		A		A	
Selection criteria Product advantages	Coating requirements	For highest requirements in terms of brilliance, material distribution, color match precision and gloss.				Universal application requirements		Finest atomization for small surfaces	
	For the use of waterborne paint systems and materials	Optionally available as stainless steel version							
	Control/Adjustment	Manual adjustment of round and flat fan as well as material flow		External adjustment of round and flat fan as well as material flow		Manual adjustment of round and flat fan as well as material flow			
	Internally controlled Pre and Post air, i.e. no external control valve required		Atomization air Continuous air flow		Internally controlled Pre and Post air, i.e. no external control valve required				

* **Material flow rate and fan size** are approximate values and depend on the nozzle size being used. These values have been determined using paints with a viscosity ranging between 17 and 24 sec. DIN 4, material pressure 0.6 - 0.9 bar and atomisation air pressure 3.5 - 4.5 bar (exact values have to be determined with the actual operating parameters and paint materials).

Selection guide for Auto and ROB spray guns

SATAmijet® 1000 ROB		SATAmijet® 1000 A S		SATA LPS 2000	SATAjet® 3000 A spray mix	Lab test spray guns	Gun type
							
HVLP	RP	HVLP		RP	spray mix	See product page	Atomization technology (RP/HVLP)
--	--	--	--	--	■	■	Internal control
■	■	■	■	--	--	■ ■	External control
22 - 27	22 - 26	16 - 27		24 - 27	Depending on material nozzle	Depending on nozzle set	* Spray fan width in cm
100 - 160	60 - 200	60 - 170		170 - 760			* Material flow in g/min
150	220	200		200			** Air consumption in l/min at 2.5 bar
■	■	■	■	■	■	--	Material circulation
--	--	--	--	■	--	--	Optional: Extensions
■	■	--	--	--	--	■	Externally controlled robotic systems
--	--	■	--	--	■	■	Robotic painting systems with adjustment of the spray parameters on the spray gun
--	--	--	--	■	--	--	Marking applications, component marking
Standard: -- Stainless steel: 620		Standard: 520 Stainless steel: --		Standard: 525 Stainless steel: --	Standard: 625 Stainless steel: 835	Depending on the model execution	Spray gun weight in g
125		125		127	145		Spray gun length in mm
45 x 45		35 x 35		35 x 35	45 x 45	45 x 45	Width x height in mm
--		--		--	--	45°	Air cap fixation
HVLP: 0.3; 0.5; 0.8; 1.0; 1.2		RP Round/flat fan: 0.5; 0.8; 1.3; 2.0 RP round fan: 0.5; 0.8		Depending on the model version (see pages with details)	Depending on the model version (see pages with details)	Depending on the model version (see pages with details)	Available nozzle sizes
RP: 0.3; 0.5; 0.8; 1.0; 1.2							
--	■	■	■	■	--	--	Standard version Anodized aluminium
■	--	--	--	■	■	■	Stainless steel version
G 1/4 Female thread	G 1/4 Female thread	G 1/4 Female thread	G 1/4 Female thread	G 1/4 Female thread	G 1/4 Female thread	G 1/4 Female thread	Connection thread Material inlet/-outlet, control air, atomization air
ROB	--	--	--	--	--	--	Optional: Quick change adapter
Finest atomisation for small surfaces		Defined edge marking, high frequency		Atomisation air supported air mix/spray mix technology	Colour tone and paint batch control in laboratories	Coating requirements	
Optionally available as stainless steel version	--	--	--	Airless technology/max. material pressure range up to 250 bar	Scalable and reproducible adjustment parameters	For the use with waterborne paint systems and materials	
External adjustment of round and flat fan as well as material flow	Manual adjustment of round and flat fan as well as material flow		--	High surface efficiency with low overspray	Gravity flow cup version with suction nozzle technology	Control/Adjustment	
Atomization air Continuous air flow	Atomization air continuous flow				Internally controlled Pre and Post air, i.e. no external control valve required		



Technical modifications and printing errors reserved

SATAjet® 3000 ROB RP®/HVL P

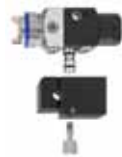

SATAjet 3000 ROB RP								
Technical Data		Operating pressure: 51 - 58 psi						
		Air consumption: 15.5 cfm						
Nozzle Size	0.5	0.8	1.1	1.3	1.5	1.7	2.0	
Standard version with Standard (STD) or Specially Treated (ST) Nozzle								
Part No. STD	163931	94516	94524	135467	94550R	94559R	94570R	
Part No. ST	-	94516ST	94524ST	137893	94550RST	94559RST	94570RST	
Waterborne version with Standard (STD) or Specially Treated (ST) Nozzle								
Part No. STD	-	94557	94565	130476	94585R	94593R	94603R	
Part No. ST	-	146928	94565ST	130476ST	94585RST	94593RST	94603RST	
Nozzle Set	0.5	0.8	1.1	1.3	1.5	1.7	2.0	
Part No. STD	129932	94136	94144	128322	135459	94170R	144253	
Part No. ST	129932ST	137992	140889	138008	94160RST	94170RST	128777ST	

SATAjet 3000 ROB HVL P								
Technical Data		Operating pressure: 58 - 61 psi						
		Air consumption: 20 cfm						
Nozzle Size	0.5	0.8	1.0	1.2	1.6	2.0		
Standard version with Standard (STD) or Specially Treated (ST) Nozzle								
Part No. STD	-	94532	94540	124651	180976	94568R		
Part No. ST	-	94532ST	94540ST	124651ST	94556RST	94568RST		
Waterborne version with Standard (STD) or Specially Treated (ST) Nozzle								
Part No. STD	-	94573	94581	124644	129395	129403		
Part No. ST	-	94573ST	94581ST	124644ST	129395ST	129403ST		
Nozzle Set	0.5	0.8	1.0	1.2	1.6	2.0		
Part No. STD	129940	94151	94169	126433	124206	124214		
Part No. ST	-	139667	94169ST	138016	140814	140822		

SATAjet 3000 ROB HVL P ACCESSORIES		
197715	Quick change adapter for one SATA ROB spray gun, with fixing screw, without spacer blocks 52720 and connection 53132 NOTE: aluminum plate is not included in delivery	
Inquire for product number	Adapter with or without recirculation for ROB spray guns	
208603	FIRA (Fluid Integrated Regulator Adapter) quick change adapter with integrated material fine pressure regulator, includes connection elements for SATAjet ROB automatic guns. Innovative, compact adapter for automatic spray guns allowing the quick removal of the automatic gun for maintenance purposes. Furthermore, a pneumatically operated material fine pressure regulator is integrated in the adapter ensuring a pulsation free material supply. The controller can be either adjusted centrally via the pneumatic anchorage or externally via the control of the entire unit.	

All SATA robotic and automatic spray guns and internal components, attachments, and accessories are made to order and not returnable. Please allow several weeks for delivery.

Spare Parts SATAjet® 3000 ROB RP®/HVLP

Part No./Descr.	
10033	Air cap ring w/seal, 3000 RP
14183	Tool kit
41780	Gun body only (specify gun)
43091	Control piston
43109	Closing cap
64071	Seal retainer
64147	Washer
64709	Sleeve
64808	Spring, compression
68999	Repair kit
68999-S	Spring set
74179	Inner material seal
74690	Allen screw, M5x25
80598	Seal retainer
91728	Front mount
92627	Nozzle head, 3000 ROB HVLP & RP
93732	S/S nozzle head, 3000 ROB HVLP & RP
97824	Air cap ring w/seal, HVLP
97824	Air distribution ring, w/puller, pk of 3
170787	Seal retainer
170787	Rear mount

Rear mount seal #170787 (Late 2014 release)

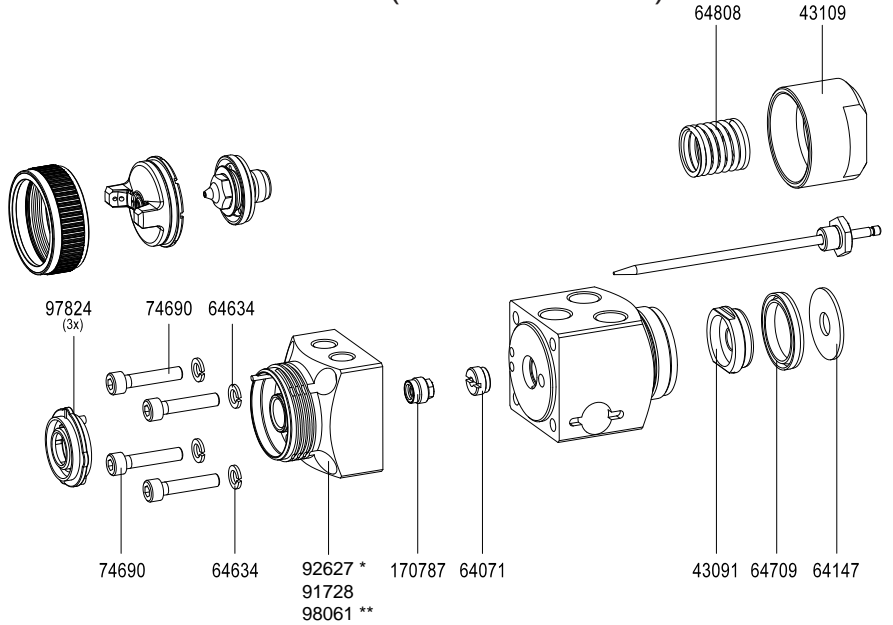

14183 Tool Kit (common)

- Universal spanner wrench
- Cleaning brush
- Extraction tool
- Allen wrench 4mm
- Socket wrench

Part No./Descr.

217505
Repair kit

ROB Accessories and parts

Part No./Descr.	
74773	Single Gun Adapter, LP ROB
56622	Dual Gun Adapter, LP ROB
53132	Connection Bolt G1/4, Adapter Plate
52720	Spacer Block, Pk of 3, Adapter Plate
145904	O Ring only, Pk of 10

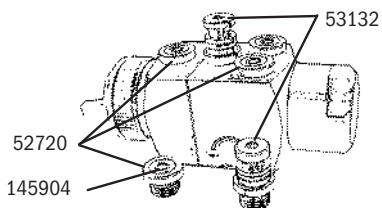

Front mount seal #80598

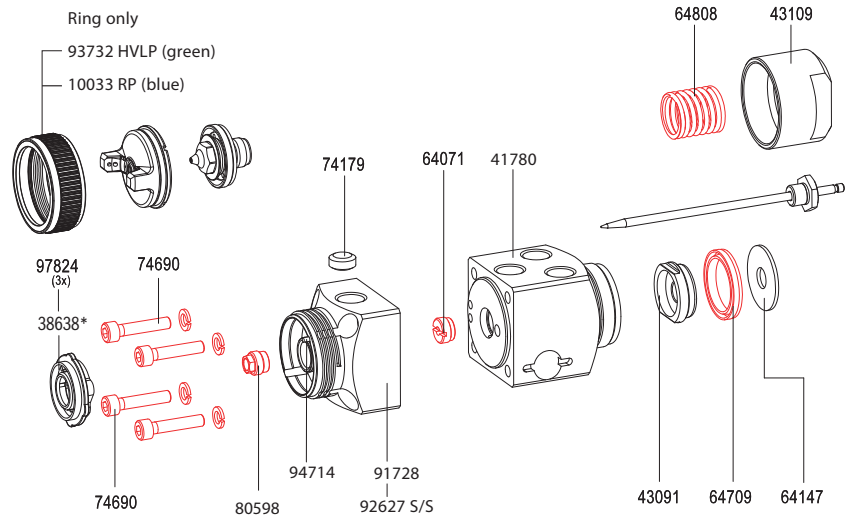





Part No./Descr.

68999
Repair kit

Technical modifications and printing errors reserved

Quick change adapter SATAjet A / ROB

Quick-change recording quick change holders		
145169	Quick-change adapter cpl. SATA automatic guns , with mounting screw, with spacers 52720	
208595	<p>FIRA quick-change adapter with integrated precision pressure regulator , incl. connecting elements for SATAjet A automatic guns</p> <p>FIRA (Fluid Integrated Regulator Adapter) quick change adapter with integrated material fine pressure regulator, includes connection elements for SATAjet ROB automatic guns.</p> <p>Innovative, compact adapter for automatic spray guns allowing the quick removal of the automatic gun for maintenance purposes. Furthermore, a pneumatically operated material fine pressure regulator is integrated in the adapter ensuring a pulsation free material supply. The controller can be either adjusted centrally via the pneumatic anchorage or externally via the control of the entire unit</p>	
217521	Quick-change recording cpl. including without material return . Connection elements for a material connection for SATAjet ROB standard spray gun	
188573	Quick-change recording cpl. included with material return . connection elements for SATAjet ROB guns	
208603	FIRA quick-change recording material with integrated precision pressure regulator , incl. Connecting elements for SATAjet ROB automatic guns	
74773	Quick change adapter with fixing screw without spacers 52720 and 53132 for fitting a SATAjet ROB - gun	

Drilling patterns for quick change holders on request.

All SATA robotic and automatic spray guns and internal components, attachments, and accessories are made to order and not returnable. Please allow several weeks for delivery.

FIRA quick change adapter SATAjet A / ROB

Only for the series ▶

- SATAjet 3000 A RP/HVLP
- SATAjet 1000 A RP/HVLP
- SATAmijet 1000 A RP/HVLP

Part No./Desc.
52720
Spacer 1/4" (external thread) (3x)
145169
Quick-change recording cpl. SATA automatic guns , with mounting screw, with spacers 52720

Hole pattern of the mounting holes on request.

- Included in 145169.

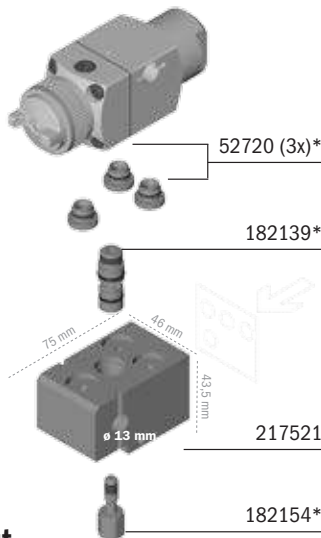
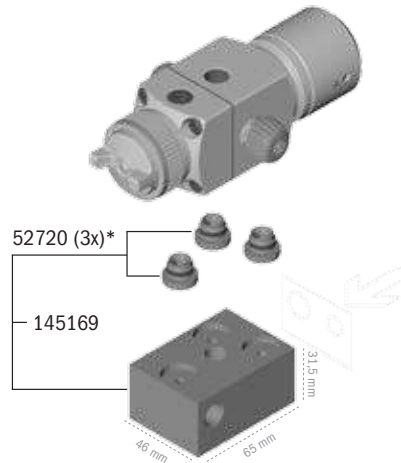

Quick-change recording without material circulation

Only for the series ▶

- SATAjet 3000 ROB RP/HVLP
- SATAmijet 1000 ROB RP/HVLP (on demand)

Part No./Desc.
52720
Spacer 1/4" (External thread) (3x)
188631
Spacer 1/8" (male) (2x)
182139
Fitting 1/4 "(male)
188573
Quick-change recording cpl. included with material return . connection elements
182154
Screw for quick-change recording cpl.

Hole pattern of the mounting holes on request.

- * included in 188573.

Quick-change recording without material circulation

Only for the series

- SATAjet 3000 ROB RP/HVLP
- SATAmijet 1000 ROB RP/HVLP

Part No./Desc.
52720
Spacer 1/4" (External thread) (3x)
182139
Fitting 1/4 "(male)
217521
Quick-change recording cpl. including without material return. Connection elements for a material connection
182154
Screw for quick-change recording cpl.

Hole pattern of the mounting holes on request.

- * Included in 217521.

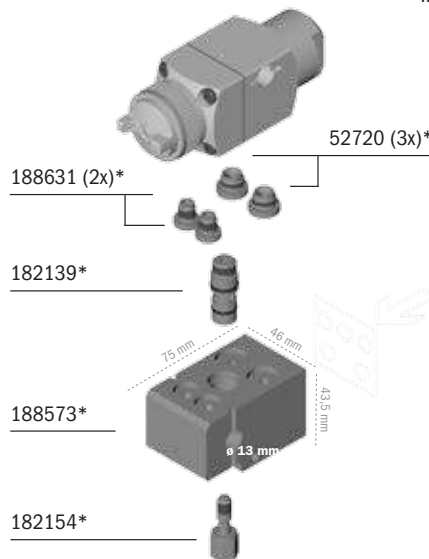

SATAjet® 3000 A RP®/HVL







SATAjet 3000 A RP							
Technical Data				Operating pressure: 51 - 58 psi			
				Air consumption: 15.5 cfm			
Nozzle Size	0.5	0.8	1.1	1.3	1.5	1.7	2.0
Standard version with Standard (STD) or Specially Treated (ST) Nozzle							
Part No. STD	-	94417	94425	94433	94445A	94453A	94461A
Part No. ST	-	94417ST	94425ST	94433ST	94445AST	94453AST	94461AST
Waterborne version with Standard (STD) or Specially Treated (ST) Nozzle							
Part No. STD	165274	94466	94474	94482	143289	94503A	94520A
Part No. ST	-	181008	94474ST	94482ST	94494AST	94503AST	94520AST
Nozzle Set	0.5	0.8	1.1	1.3	1.5	1.7	2.0
Part No. STD	129924	94326	94334	94342	94359	94369A	131052
Part No. ST	129924ST	94326ST	94334ST	94342ST	94359ST	94369AST	94377AST
Test Air Cap	135517	135517	135517	135517	135517	-	-



SATAjet 3000 A HVL							
Technical Data				Operating pressure: 58 - 61 psi			
				Air consumption: 20 cfm			
Nozzle Size	0.5	0.8	1.0	1.2	1.6	2.0	
Standard version with Standard (STD) or Specially Treated (ST) Nozzle or Carbide (CB) Nozzle							
Part No. STD	-	94441	94458	124602	124594	124545	
Part No. ST	-	94441ST	94458ST	124602ST	124594ST	125545ST	
Part No. CB	-	94490AC	94508AC	94526AC	94544AC	188276	
Waterborne version with Standard (STD) or Specially Treated (ST) Nozzle							
Part No. STD	156604	180992	94508	124610	124552	124560	
Part No. ST	-	94490ST	94508ST	124610ST	124552ST	124560ST	
Nozzle Set	0.5	0.8	1.0	1.2	1.6	2.0	
Part No. STD	129916	94367	94375	129577	129700	129718	
Part No. ST	129916ST	94367ST	94375ST	129577ST	129700ST	129718ST	
Part No. CB		96760A	96768A	96776	96784	96792	
Test Air Cap	-	95059	95059	95067	95067	95067	



Connection options		
144618	Fixing bolt, D 15 G 1/4"	
64212A	Collar mount for 1/2" shaft, G 1/4" connection	
801102	Quick change mount w/indexing angle bracket, complete with hardware Individual parts sold separately, call for part numbers.	
208595	FIRA (Fluid Integrated Regulator Adapter) quick change adapter with integrated material fine pressure regulator. Includes connection elements for SATAjet A automatic spray guns.	

All SATA robotic and automatic spray guns and internal components, attachments, and accessories are made to order and not returnable. Please allow several weeks for delivery.

Spare Parts SATAjet® 3000 A RP®/HVLP

Part No./Descr.	
1503	Countersunk screw M4 x 8
1594	Teflon seal
3418	Washer, 3.7
3574	Spring, needle packing
10033	Air cap ring w/seal, RP
11403	S/S nipple, 1/4 x 3/8
11544	Spring, needle
14183	Tool kit
29827	Spring, pk of 12
38638	Air distribution ring
54221	Control spin
64071	Seal retainer
64089	Gun body only (specify gun)
64105	Control piston
64147	Washer
64154	Hollow screw
64709	Sleeve
64766	Spacer
64808	Spring, compression
64857	Seal retainer, complete
64865	Control piston, complete
64873	End cap, complete
64881	Control cap
67082	Repair kit
67082-P	Packing set
67082-S	Spring set
69872	O ring, 11x1
70789	O ring, 5x2
73783	Hex socket screw
74179	Inner material seal
74690	Allen screw, M5x25
80598	Seal retainer
91728	Nozzle head, 3000 ROB HVLP & RP
92627	S/S nozzle head, 3000 ROB HVLP & RP
93732	Air cap ring w/seal, HVLP
93765	Nozzle head, K3 Auto HVLP & RP
93773	S/S nozzle head, w/o pin K3 Auto HVLP & RP
94714	Pin
97824	Air distribution ring, w/puller, pk of 3
133934	O ring, 11x1, pk of 3
140574	Control knob w/screw
144618	Mounting post 15mm, G 1/4"
170787	Seal retainer

Rear mount seal #170787 (Late 2014 release)

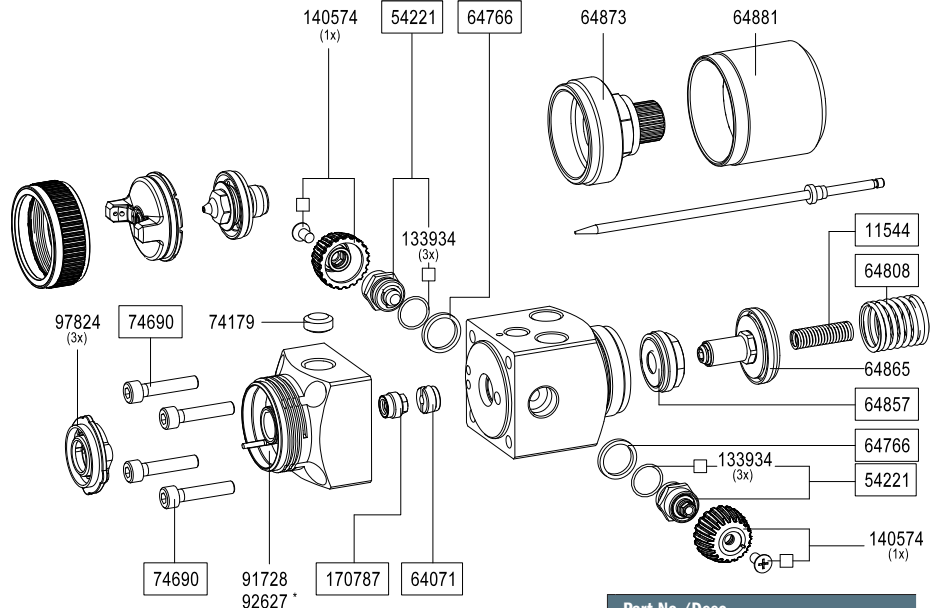

Part No./Descr.	
217505	Repair kit

14183 Tool Kit (common)

- Universal spanner wrench
- Cleaning brush
- Extraction tool
- Allen wrench 4mm
- Socket wrench

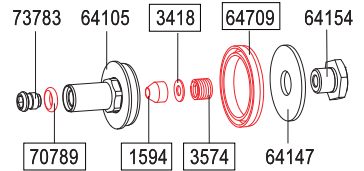

Front mount seal #80598

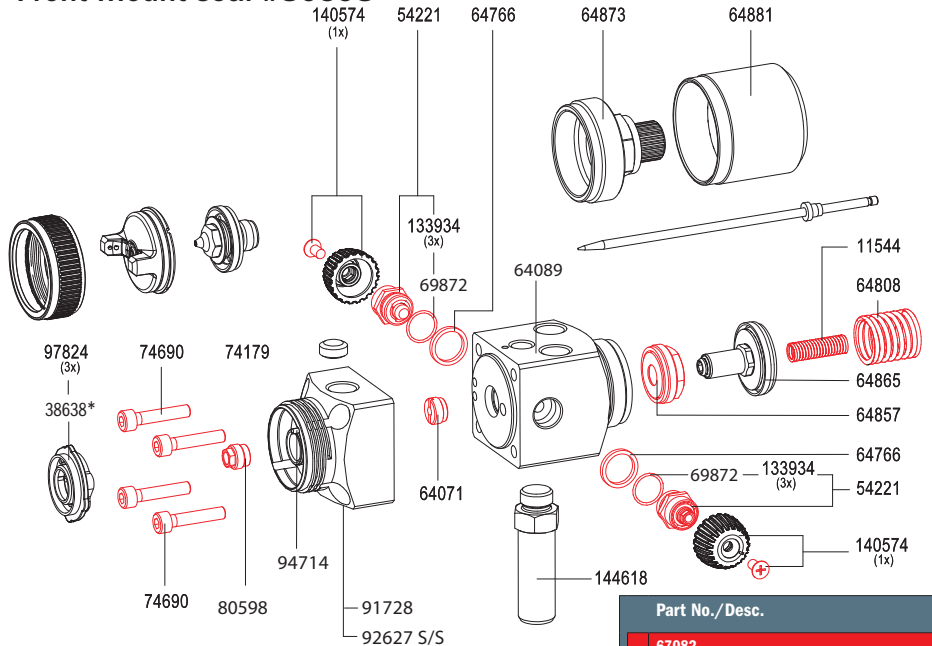

Part No./Descr.	
67082	Repair kit

SATA® 1000 A RP



SATAjet 1000 A RP

Technical Data

Air consumption 15 cfm@ 50 psi
 Operating pressure: 51 - 58 psi
 Required min. control air pressure: 45 psi
 Max permissible operation air pressure: 150 psi
 Max permissible operation material pressure: 75 psi



Nozzle Size	0.5	0.8	1.1	1.3	1.5	2.0	3.0
-------------	-----	-----	-----	-----	-----	-----	-----

Standard version with Standard (STD) or Specially Treated (ST) Nozzle

Part No. STD	195198	164129	146137	164145	165152	164160	-
Part No. SS	-	164178	165186	164194	164202	164210	185074
Nozzle Set	0.5	0.8	1.1	1.3	1.5	2.0	3.0
Part No. STD	-	164228	165236	164244	164251	164269	185082

Test air cap for the setting

184747 Test air cap 0.5 - 1.7 complete with 2 pressure gauges, for SATAjet 1000 K/A/ROB RP



SATAjet 1000 A RP without nozzle set

169870	SATAjet 1000 A RP without nozzle set
169888	SATAjet 1000 A RP Waterborne Version without nozzle set, version for waterborne paints

Plate-shaped internal mixing extension

164277	SATA plate shaped internal mixing extension for SATAjet 1000 A RP, Length 20 cm, Nozzle 1.6, 360°
164285	SATA plate shaped internal mixing extension for SATAjet 1000 A RP, Length 30 cm, Nozzle 1.6, 360°



Diagonal spray extension

164293	SATA diagonal spray extension for SATAjet 1000 A RP, Length 20 cm, Nozzle 1.6, 360°
164285	SATA plate shaped internal mixing extension for SATAjet 1000 A RP, Length 30 cm, Nozzle 1.6, 360°



Extensions SATAjet 1000 A RP

204396	Angular (90°) Extension SATAjet 1000 A RP X.XX round/flat fan
--------	---



Nozzle sizes between 0.8 and 2.0 and length between 100 and 1,000 mm are available upon request

All SATA robotic and automatic spray guns and internal components, attachments, and accessories are made to order and not returnable. Please allow several weeks for delivery.

Spare Parts SATA® 1000 A RP

Part No./Descr.	
1594	Teflon seal
3418	Washer, 3.7
3574	Spring, needle packing
11544	Spring, needle
54221	Control spin
64071	Seal retainer
64105	Control piston
64147	Washer
64154	Hollow screw
64709	Sleeve
64766	Spacer
64808	Spring, compression
64857	Seal retainer, complete
64865	Control piston, complete
64873	End cap, complete
64881	Control cap
70789	O ring, 5x2
73783	Hex socket screw
74179	Inner material seal
74690	Cylindrical screw, M5x25, A2 Stainless steel DIN 912 for LP90 and 1000 A guns (versions for waterborne paints)
80598	Seal retainer
133934	O ring, 11x1, pk of 3
140574	Control knob w/screw
140582	Pack of 5 sealing elements
143230	Pack of 3 air distribution rings
144618	Mounting post 15mm, G 1/4"
164095	Nozzle head, complete, jet 1000 A and ROB
164111	Nozzle head complete, waterborne paint version jet 1000 A and ROB

Rear mount seal #170787 (Late 2014 release)

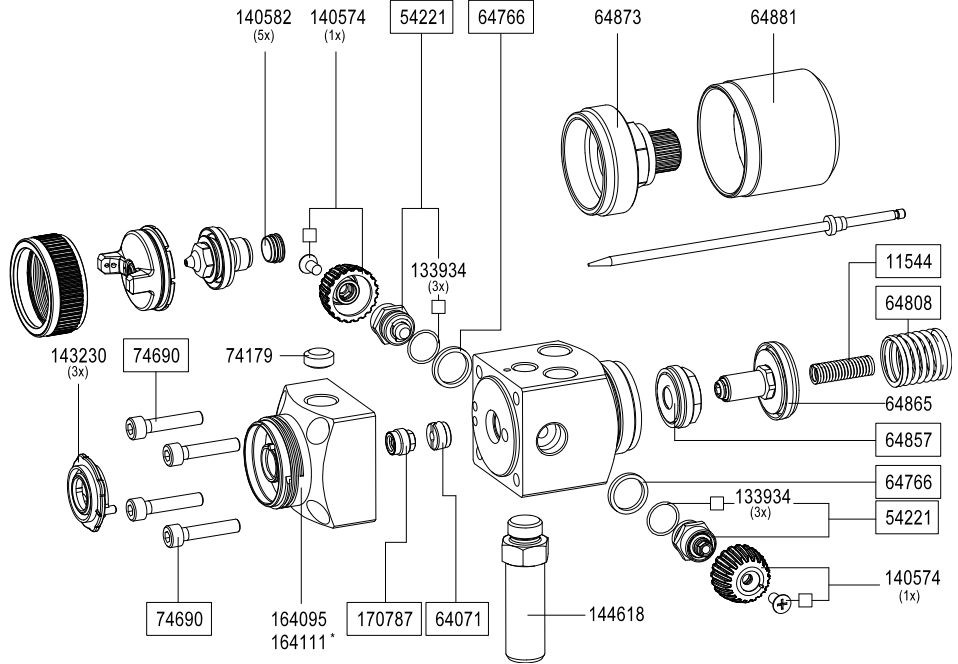

Part No./Descr.
 217505
Repair kit

14183 Tool Kit	
- Universal spanner wrench	
- Cleaning brush	
- Extraction tool	
- Allen wrench 4mm	
- Socket wrench	

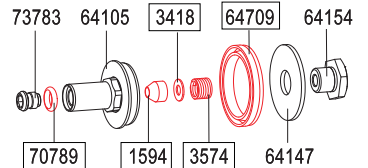

Front mount seal #80598

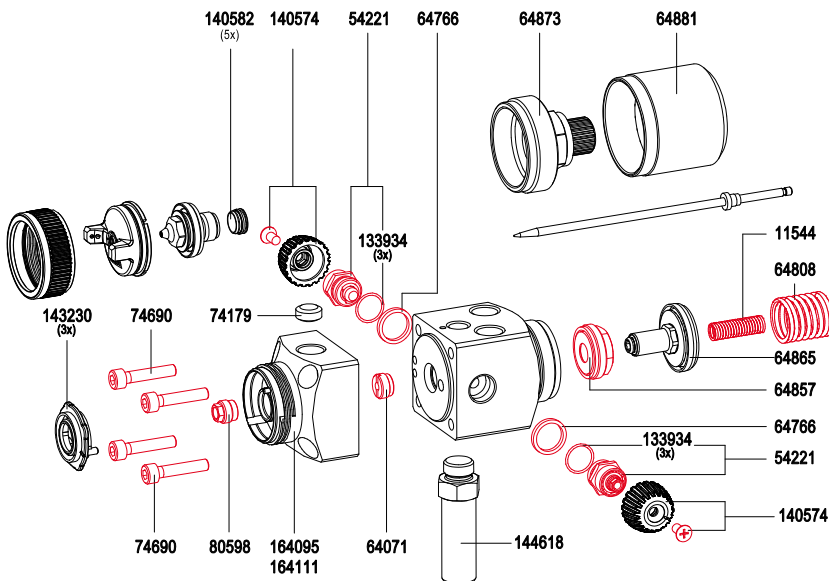

Part No./Descr.
 67082
Repair kit

Technical modifications and printing errors reserved

SATAmijet® 1000 A HVLP & RP



SATAmijet 1000 A HVLP

Technical Data	Air consumption at 36 psi: 6 cfm	
	Atomization air pressure on the spray gun: 36 - 45 psi	
	Required min. control air pressure: 45 psi	
	Maximum permissible material operating pressure: 145 psi	
	Maximum permissible operation temperature of the coating material: 80° C	
	Weight cpl. without connections:	Stainless steel: 915 g



Nozzle Size	0.3	0.5	0.8	1.0	1.2	1.4
--------------------	-----	-----	-----	-----	-----	-----

Stainless steel version

Part No.	170746	170753	170761	170779	194902	*
Nozzle Set	0.3	0.5	0.8	1.0	1.2	1.4
Part No.	171009	171017	171025	171033	203711	*

* available upon request

Test air caps for setting the required spray parameters (reproducibility)

126474	Test air cap 0.8 - 1.1 , with 2 pressure gauges, cpl.. for SATAmijet 1000 K/A/ROB HVLP	
204875	Test air cap 0.3 - 1.2 , with 2 pressure gauges, cpl.. for SATAmijet 1000 K/A/ROB HVLP	

Connection kits page 74-75

SATAmijet 1000 A RP

Technical Data	Air consumption at 36 psi: 7 cfm	
	Atomization air pressure on the spray gun: 36 - 45 psi	
	Required min. control air pressure: 45 psi	
	Maximum permissible material operating pressure: 72 psi	
	Maximum permissible operation temperature of the coating material: 80° C	
	Weight cpl. without connections:	Stainless steel: 915 g



Nozzle Size	0.3	0.5	0.8	1.0	1.2
--------------------	-----	-----	-----	-----	-----

Stainless steel version

Part No.	*	203596	203604	*	*
Nozzle Set	0.3	0.5	0.8	1.0	1.2
Part No.	203661	203679	203687	203695	203703

* available upon request

Test air caps for setting the required spray parameters (reproducibility)

204867	Test air cap 0.3 - 1.2 , with 2 pressure gauges, cpl.. for SATAmijet 1000 K/A/ROB RP	
--------	---	--

Connection kits page 74-75

All SATA robotic and automatic spray guns and internal components, attachments, and accessories are made to order and not returnable. Please allow several weeks for delivery.

Spare Parts SATAmijnjet® 1000 A HVLP

Part No./Descr.	
1594	Teflon seal
3418	Washer, 3.7
3574	Spring, needle packing
11544	Spring, needle
54221	Control spin
64071	Seal retainer
64105	Control piston
64147	Washer
64154	Hollow screw
64709	Sleeve
64766	Spacer
64808	Spring, compression
64857	Seal retainer, complete
64865	Control piston, complete
64873	End cap, complete
64881	Control cap
70789	O ring, 5x2
73783	Hex socket screw
74179	Inner material seal
74690	Cylindrical screw, M5x25, A2 Stainless steel DIN 912 for LP90 and 1000 A guns (versions for waterborne paints)
127399	Pack of 3 air distribution ring
133934	O ring, 11x1, pk of 3
140574	Control knob w/screw
144618	Mounting post 15mm, G 1/4"
170787	Seal retainer, complete material side, minijet 3000 A and ROB
170803	Nozzle head, complete, version waterborne paint, SATAmijnjet 3000 A and ROB WA

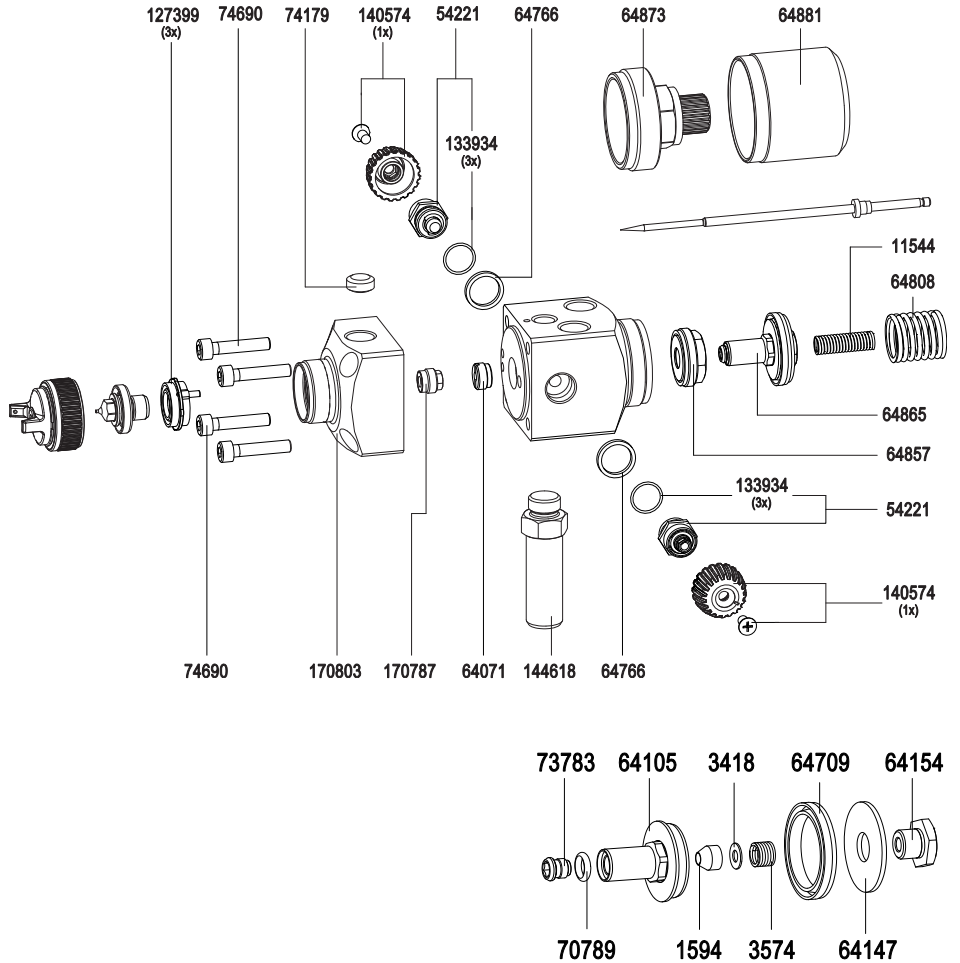

Art. No./Descr.	
14183	Tool kit
	<ul style="list-style-type: none"> · Extraction tool · Socket wrench SW 7 · Cleaning brush · Allen wrench 4 mm width · Universal spanner



Technical modifications and printing errors reserved

SATAmijet® 1000 ROB RP

SATAmijet 1000 ROB RP

Technical Data	Air consumption at 36 psi: 7 cfm		
	Atomization air pressure on the spray gun: 36 - 45 psi		
	Required min. control air pressure: 43 psi		
	Maximum permissible material operating pressure: 145 psi		
	Maximum permissible operation temperature of the coating material: 80° C		
Weight cpl. without connections:		Stainless steel:	620 g



Nozzle Size	0.3	0.5	0.8	1.0	1.2
--------------------	-----	-----	-----	-----	-----

Stainless steel version

Part No.	*	203612	203620	*	*
-----------------	---	--------	--------	---	---

Nozzle Set	0.3	0.5	0.8	1.0	1.2
-------------------	-----	-----	-----	-----	-----

Part No.	203729	195206	203737	203745	203752
-----------------	--------	--------	--------	--------	--------

* available upon request

Test air caps for setting the required spray parameters (reproducibility)

204867	Test air cap 0.3 - 1.2 , with 2 pressure gauges, cpl.. for SATAmijet 1000 K/A/ROB RP
--------	---



Connection kits page 74-75

All SATA robotic and automatic spray guns and internal components, attachments, and accessories are made to order and not returnable. Please allow several weeks for delivery.

Spare Parts SATAmijet® 1000 ROB RP

Part No./Descr.
43091 Control piston
43109 Closing cap
64071 Seal retainer
64147 Washer
64709 Sleeve
64808 Spring, compression
74179 Inner material seal
74690 Cylindrical screw, M5x25, A2 Stainless steel DIN 912 for LP90 and 1000 A guns (versions for waterborne paints)
127399 Pack of 3 air distribution ring
170787 Seal retainer, complete material side, minijet 3000 A and ROB
203588 Nozzle head, cpl. SATAmijet 1000 A and 1000 minijet ROB, stainless steel

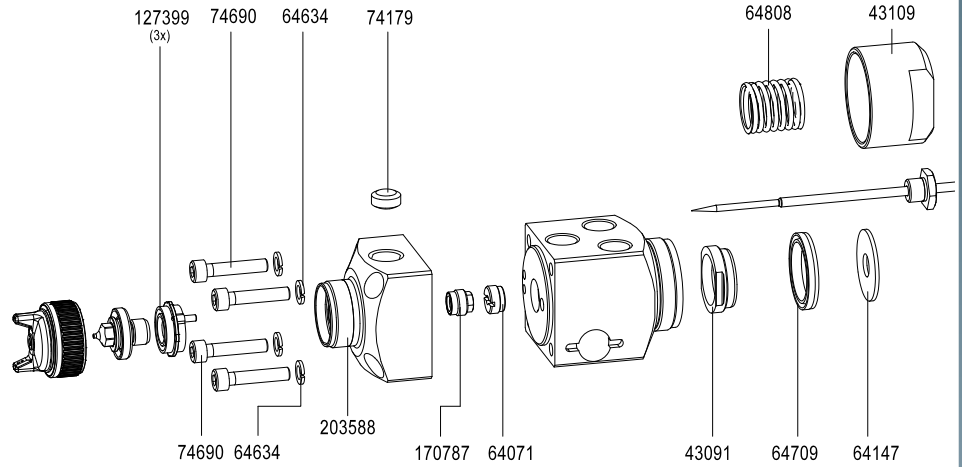

Art. No./Descr.	
14183	
Tool kit	
· Extraction tool	
· Socket wrench SW 7	
· Cleaning brush	
· Allen wrench 4 mm width	
· Universal spanner	



SATAmijet® 3000 A S HVLP

SATAmijet 3000 A S HVLP

Technical Data	Air consumption: 7 cfm at 43 psi
	Atomization air (72-80 psi) min. \varnothing 8 mm
	Required min. control air pressure: 43 psi
	Maximum permissible operating air pressure: 150 psi
	Maximum permissible operating material pressure: 75 psi
	Maximum permissible operation temperature of the coating material: 80° C



Nozzle Size	0.3	0.5	0.8	1.0
--------------------	-----	-----	-----	-----

Stainless steel version

Part No.	149021	149039	149047	149054
Nozzle Set	0.3	0.5	0.8	1.0
Part No.	149476	149484	149492	149500

* available upon request

Test air caps for setting the required spray parameters (reproducibility)

126474	Test air cap 0.8 - 1.1	
--------	-------------------------------	--

Connection diagram | Material and air connections G 1/4 female thread

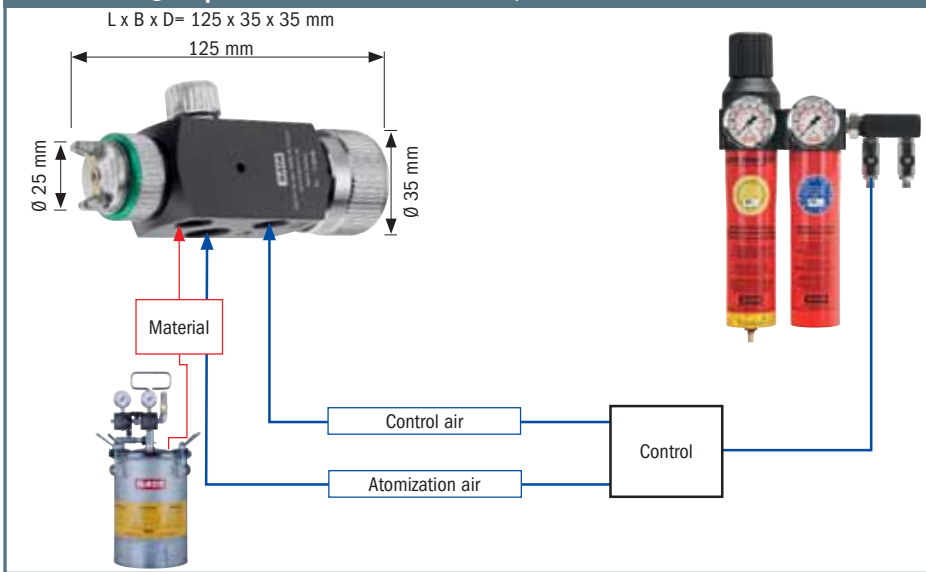

All SATA robotic and automatic spray guns and internal components, attachments, and accessories are made to order and not returnable. Please allow several weeks for delivery.

Spare Parts SATAminijet® 3000 A S HVLP

Part No./Descr.	
1503	Countersunk screw M4 x 8
1933	Teflon Sealing for paint needle packing unit, pack of 5
2188	Spindle, complete for regulation valve
3418	Washer, 3.7
3574	Spring, needle packing
3582	Packing screw for paint needle
20297	Compression spring
22418	Teflon sleeve
24349	Backing plate
40253	Regulation cap
45385	Hex nut M9x1 for taking sleeve
57976	Distance sleeve for SATA LP/S making gun ready for assembly
65557	Regulating knob and valve
67116	Locking screw MS R1/4 inch for LP90 and breathing set NIOSH
127399	Pack of 3 air distribution rings
144618	Rixking bold D 15 - G 1/4

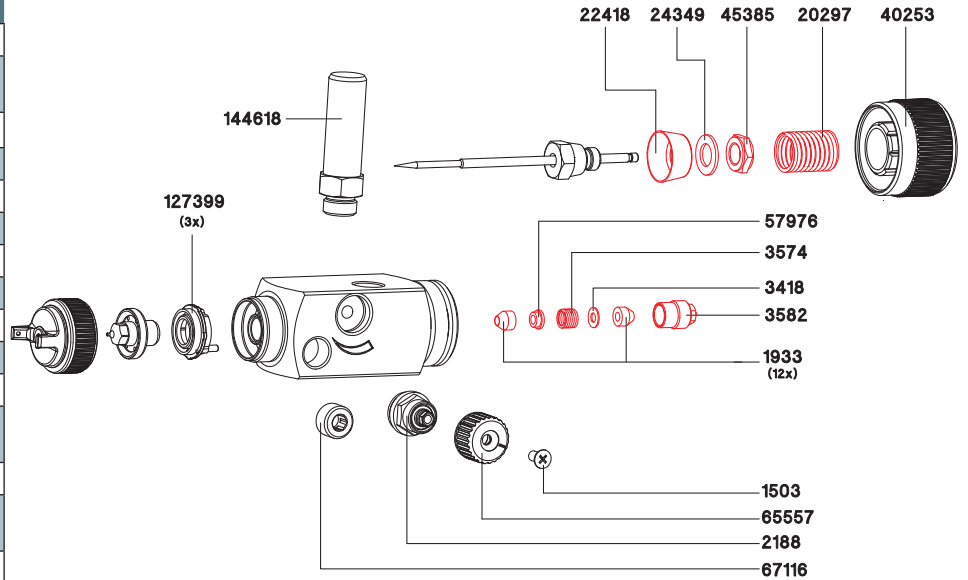

Art. No./Descr.	
14183	
Tool kit	
· Extraction tool	
· Socket wrench SW 7	
· Cleaning brush	
· Allen wrench 4 mm width	
· Universal spanner	

Art. No./Descr.
40832
Repair kit for SATA LP-S

SATAmijet® 3000 ROB HVLP



SATAmijet 3000 ROB HVLP

Technical Data	Air consumption: 4 cfm at 50 psi
	Operating pressure: 26 psi
	Atomization air (50-60 psi) min. \varnothing 6 mm
	Required min. control air pressure: 45 psi
	Maximum permissible operation temperature of the coating material: 80° C



Nozzle Size	0.3	0.5	0.8	1.0	1.2	1.4
--------------------	-----	-----	-----	-----	-----	-----

Stainless steel version without material circulation for the use on quick change adapter 188557

Part No.	-	194894	188862	-	188870	-
-----------------	---	--------	--------	---	--------	---

Nozzle Set	0.3	0.5	0.8	1.0	1.2	1.4
-------------------	-----	-----	-----	-----	-----	-----

Part No.	182675	185652	185660	185678	185686	185694
-----------------	--------	--------	--------	--------	--------	--------

* available upon request

Test air caps for setting the required spray parameters (reproducibility)

126482	Test air cap 0.8 - 1.0 SR
--------	----------------------------------



Connection diagram | Material and air connections G 1/4 female thread

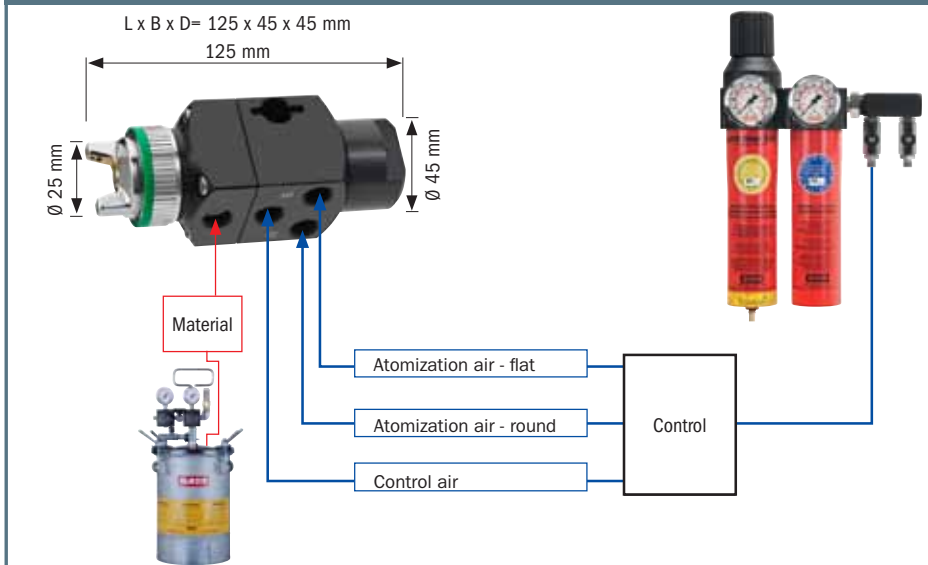

All SATA robotic and automatic spray guns and internal components, attachments, and accessories are made to order and not returnable. Please allow several weeks for delivery.

Spare Parts SATAminijet® 3000 ROB HVLP

Part No./Descr.
43091 Control piston
43109 Closing cap
64071 Seal retainer
64147 Washer
64709 Sleeve
64808 Spring, compression
74690 Cylindrical screw, M5x25, A2 Stainless steel DIN 912 for LP90 and 1000 A guns (versions for waterborne paints)
127399 Pack of 3 air distribution ring
170787 Seal retainer, complete material side, minijet 3000 A and ROB
185611 Nozzle head, cpl. version for waterborne paints SATAminijet 3000 A and ROB WA without material circulation

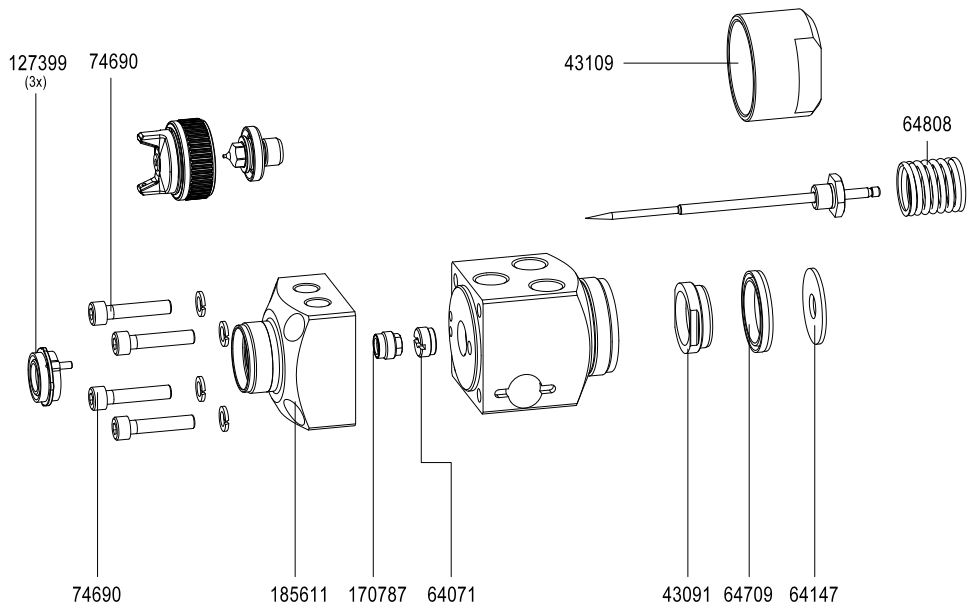

Art. No./Descr.
14183
Tool kit
<ul style="list-style-type: none"> · Extraction tool · Socket wrench SW 7 · Cleaning brush · Allen wrench 4 mm width · Universal spanner





SATAjet® LPS 2000 RP®



SATAjet LPS 2000 RP

Technical Data	Air consumption SATA LPS RB 2000 RP 7-9 cfm at 45 psi
	Air consumption SATA LPS R 2000 RP 4-5 cfm at 29 psi
	Required min. control air pressure: 45 psi
	Maximum permissible air operating pressure: 150 psi
	Maximum permissible material operating pressure: 75 psi
Permanent atomisation air for high operating frequencies	

Nozzle Size	0.5	0.8	1.3	2.0
--------------------	-----	-----	-----	-----

Stainless steel version

Part No.	92908	92916	129726	177444
-----------------	-------	-------	--------	--------

Nozzle Set	0.5	0.8	1.3	2.0
-------------------	-----	-----	-----	-----

Part No.	-	93021	93039	-
-----------------	---	-------	-------	---

Nozzle Size	0.5	0.8
--------------------	-----	-----

SATA LPS R 2000 marketing gun with round fan

Part No.	92940	*
-----------------	-------	---

Nozzle Set	0.5	0.8
-------------------	-----	-----

Part No.	93047	93054
-----------------	-------	-------

Connection diagram | Material and air connections G 1/4 female thread

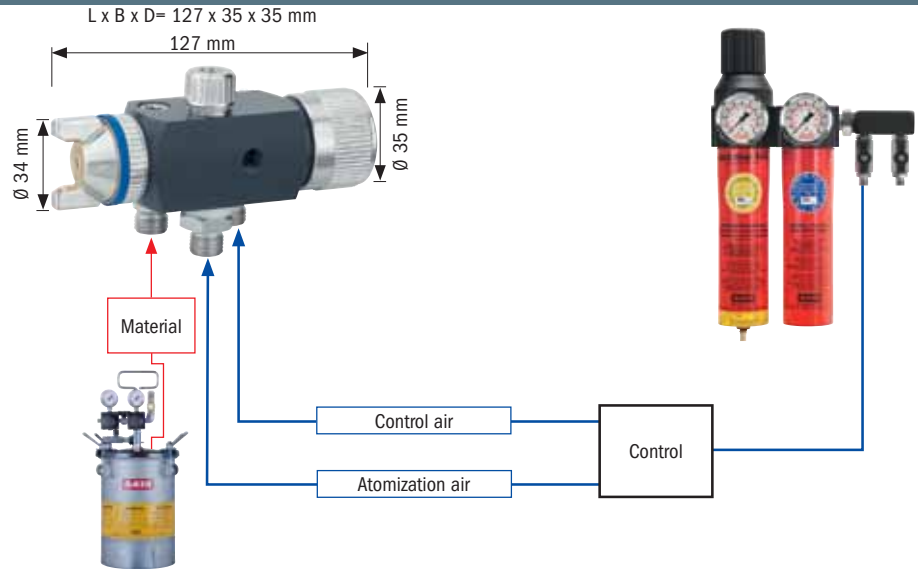

All SATA robotic and automatic spray guns and internal components, attachments, and accessories are made to order and not returnable. Please allow several weeks for delivery.

Parts SATAjet® LPS 2000 RP®



Part No./Descr.	
1503	Countersunk screw M4 x 8
1933	Teflon Sealing for paint needle packing unit, pack of 5
3418	Washer, 3.7
3574	Spring, needle packing
3582	Packing screw for paint needle
3657	Control knob & regulation valve
3939	Spindle, complete for LP90 lab test gun
20297	Compression spring
22418	Teflon sleeve
24349	Backing plate
40253	Regulation cap
40832	Repair kit
45385	Hex nut M9x1 for taking sleeve
57976	Distance sleeve for SATA LP/S making gun ready for assembly
62513	Air distribution ring, sn. below 30,000
64212	14mm, M10 x 1.5
64766	Spacer
67116	Locking screw Ms R1/4 inch for LP90 and breathing set NIOSH
69724	Closing screw LP-90-spray mix
133934	Pack of 3 packings
134593	Pack of 3 air distribution rings for SATA LM 2000
144618	Fixing bolt D 15 - G 1/4

SATA LPS RB 2000 RP

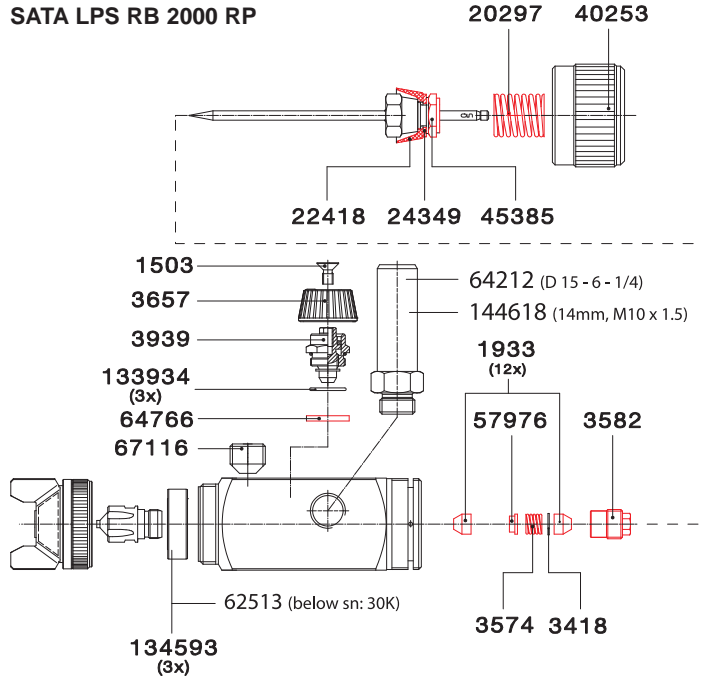

SATA LPS R 2000

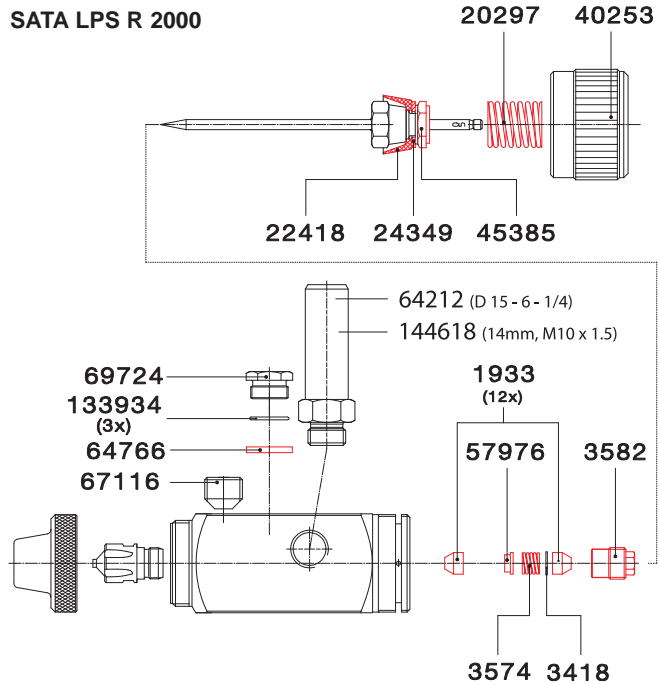

14183 Tool Kit

- Universal spanner wrench
- Cleaning brush
- Extraction tool
- Allen wrench 4mm
- Socket wrench

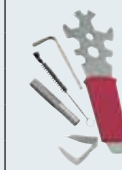

Art. No./Descr.

40832
Repair kit for SATA LP-S



SATAjet® 3000 A spray mix

SATAjet 3000 K spray mix

Technical Data	Air consumption at 45 psi	Flat fan: 3 cfm
		Round fan: 8 cfm
	Required min. control air pressure: 45 psi	
	Maximum permissible operating pressure: 150 psi	
	Maximum permissible operating material pressure: 3626 psi	
	Maximum permissible operating temperature of the coating material: 49° C	



Standard version

144519	SATAjet 3000 A spray mix with round/flat spray control, without material nozzle
--------	---

Stainless steel version

144527	SATAjet 3000 A spray mix for waterborne materials, with round/flat spray control, without material nozzle
--------	---

Strainer

38265	Strainer for SATA pressure fed spray guns G3/8 female thread, 60 mesh, WA version
-------	---

Nozzles - SATAjet 3000 K spray mix

Fluid tip		Reversing nozzle for reversing switch		Technical Data					Strainer	
Nozzle No.	Part No.	Nozzle No.	Part No.	ø mm	ø inch	Angle	Width In.	oz/min @ 1015 psi		
1840	23044*			0.18	0.007	40°	7	5.41		
2325	7328			0.23	0.009	25°	6	7.78	200 msh 85 µm	74856 4 per set
2350	7435			0,23	0.009	50°	9	7.78		
2360	74922			0.23	0.009	60°	10	7.78		
		2550	120220	0.25	0.010	20°/50°	4/9	8.45		
2825	16998			0.28	0.011	25°	6	10.14		
2850	50906			0.28	0.011	50°	9	10.14		
2865	13771			0.28	0,011	65°	10	10.14		
		3050	120238	0.30	0.012	20°/50°	4/9	12.85	100 msh 150 µm	12278 4 per set
3325	20206			0.33	0.013	25°	6	15.22		
3350	50898			0,33	0.013	50°	9	15.22		
3365	13789			0.33	0.013	65°	11	15.22		
3375	74930			0.33	0.013	75°	13	15.22		
3390	73742			0.33	0.013	90°	16	15.22		
		3550	120246	0,35	0,014	20°/50°	4/9	17		
3825	13797			0,38	0,015	25°	6	20.63	60 msh 250 µm	12260 4 per set
3850	7344			0,38	0,015	50°	10	20.63		
3882	74948			0,38	0,015	82°	14	20.63		
		4050	120253	0,40	0,016	20°/50°	4/9	23.6		
4650	19307			0,46	0,018	50°	9	32		
4682	74955			0,46	0,018	82°	14	32		
5370	150276			0,53	0,021	70°	13	42		
6050	17004			0,60	0,024	50°	12	53.76		

Connection kits page 74-75

All SATA robotic and automatic spray guns and internal components, attachments, and accessories are made to order and not returnable. Please allow several weeks for delivery.

Spare Parts SATAjet® 3000 A spray mix

Part No./Descr.	
1594	Teflon seal for paint needle
3046	Seal retainer, complete for nozzle head
3418	Washer, 3.7
3574	Spring, needle packing
18341	Compression Spring
54221	Spindle complete
64105	Control piston for SATA LP, ready for assembly
64197	Washer for SATA LP, ready for assembly
64709	Sleeve for SATA LP910
64766	Spacer
64808	Compression spring
64857	Seal retainer, big, complete with piston packing
64865	Control piston for SATA LP90
69708	Seal retainer for LP90/Spray mix complete w/ needle packing
70789	O-ring 5x2 mm, ethylene-propylene
73783	Hexagonal socket head screw
74179	Intermediate piece
74690	Cylindrical screw M5x25, A2 stainless steel, DIN 912, for LP90 guns (version for waterborne paints)
97824	Pack or 3 air distribution rings
98434	Pre-nozzle, complete
98459	Air cap, round/flat
98541	Needle tip
98665	Air cap ring
133934	Pack of 3 packings
140574	Control knob & screw (1 ea)
144535	Nozzle head, complete
144543	Nozzle head complete for waterborne materials
144618	Fixing bolt D 15 - G 1/4
144626	Closing cap
144642	Paint needle, complete with needle sleeve

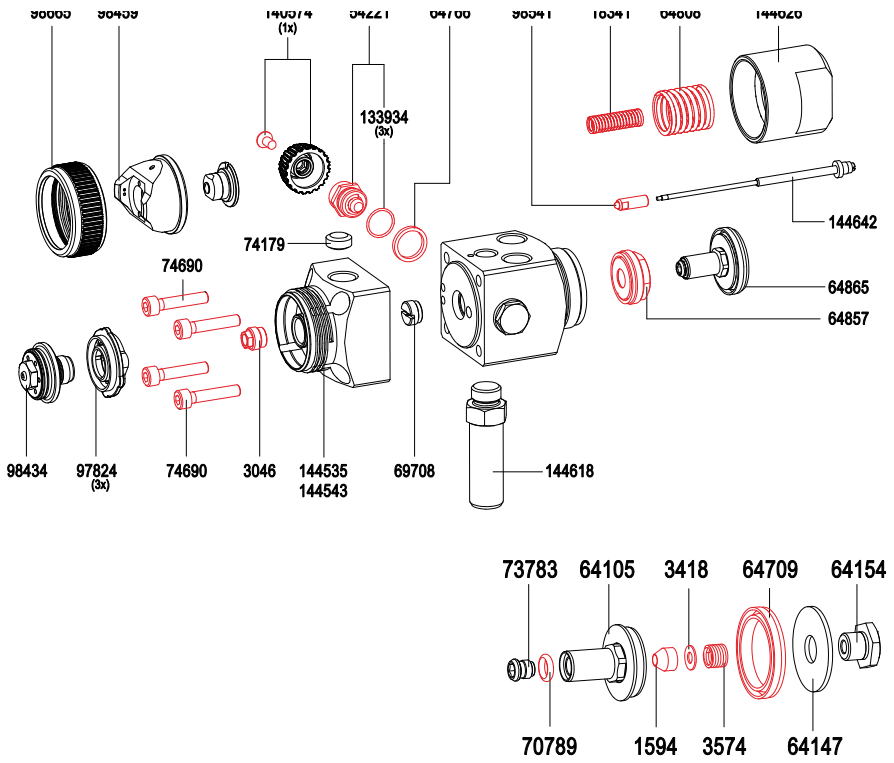

Art. No./Descr.
14183
Tool kit
· Extraction tool
· Socket wrench SW 7
· Cleaning brush
· Allen wrench 4 mm width
· Universal spanner

Art. No./Descr.
144733
Repair kit LP jet K3 spray mix

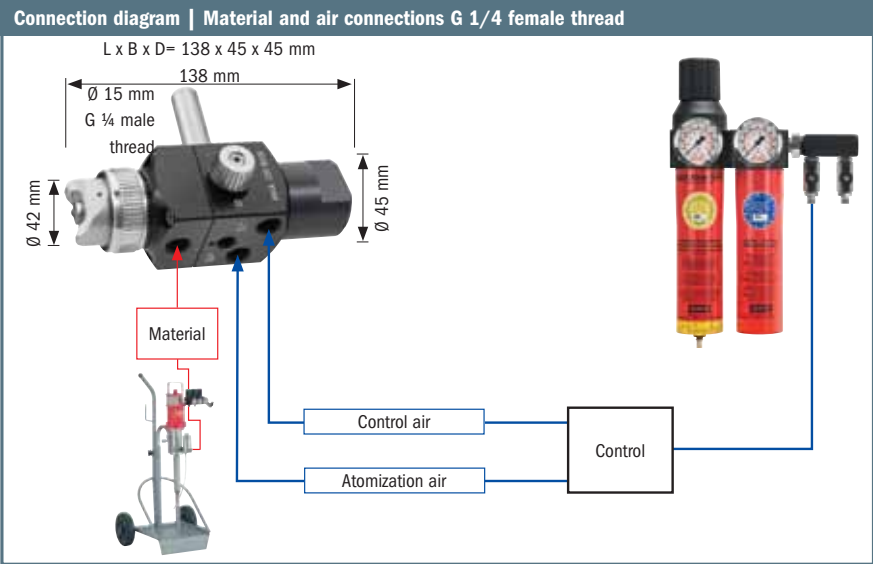

Technical modifications and printing errors reserved



Cup Systems



SATA® RPS™ System



SATA RPS		
SATA RPS 0.3 I minijet		
118299	SATA RPS 0.3 I minijet 125 µm flat sieve, 60-pk (SATAmijet 3000 B and earlier)	
118414	SATA RPS 0.3 I minijet 200 µm plug-in sieve, 60-pk (SATAmijet 3000 B and earlier)	
SATA RPS 0.3 I Standard sized guns		
118281	SATA RPS 0.3 I 125 µm flat sieve, 60-pk	
118406	SATA RPS 0.3 I 200 µm plug-in sieve, 60-pk	
SATA RPS 0.6 I		
125062	SATA RPS 0.6 I 125 µm flat sieve, 57-pk	
125070	SATA RPS 0.6 I 200 µm plug-in sieve, 57-pk	
151746	SATA RPS 0.6 I 200 µm flat sieve, 57-pk	
SATA RPS 0.9 I		
118471	SATA RPS 0.9 I 125 µm flat sieve, 40-pk	
118489	SATA RPS 0.9 I 200 µm plug-in sieve, 40-pk	
151720	SATA RPS 0.9 I 200 µm flat sieve, 40-pk	
SATA RPS 0.6 I UV		
139451	SATA RPS UV 0.6 I 125 µm flat sieve, 57-pk	
139469	SATA RPS UV 0.6 I 200 µm plug-in sieve, 57-pk	

Spare Parts SATA® RPS™

Part No./Desc.
131961 80-pk spare lids for 0.6 l and 0.9 l cups
131979 100-pk 125µ blue flat sieves for 0.6 l and 0.9 l cups
131987 100-pk 200µ green plug-in sieves for all sizes
144964 100-pk 200µ green flat sieves for 0.6 l and 0.9 l cups
160606 60-pk 125µ blue flat sieves for 0.3 l cups
167908 90-pk spare lids for 0.3 l cups for standard guns
167916 108-pk spare lids for 0.3 l cups for minijet spray guns

SATA RPS 0.3 l Standard

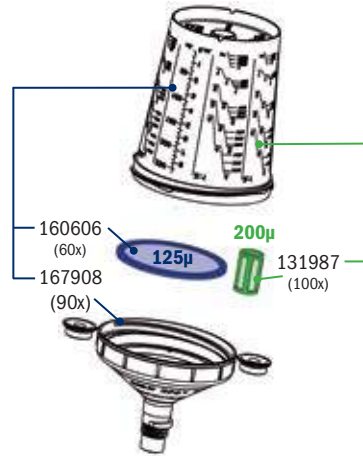

SATA RPS 0.3 l minijet

(SATAMinijet 3000B and earlier)

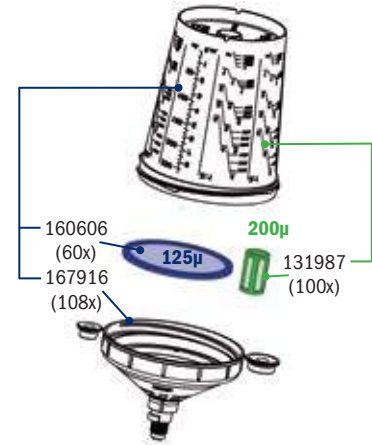



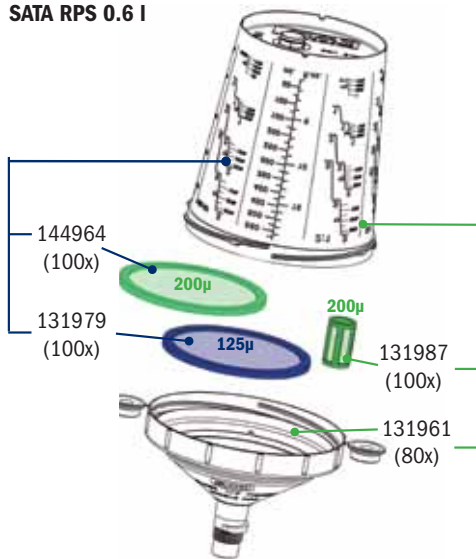



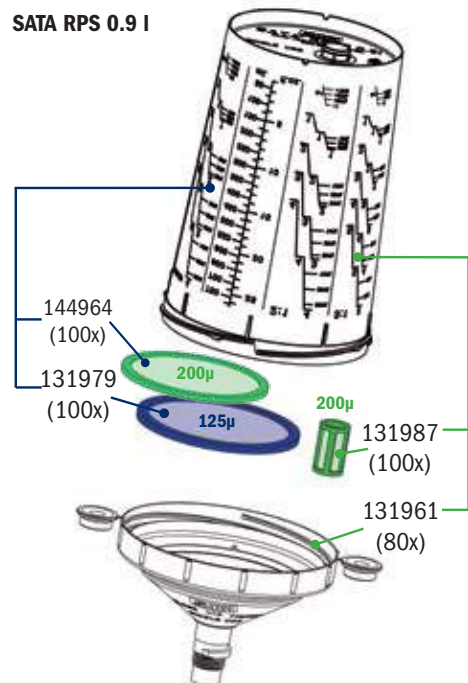

SATA RPS 0.6 l



SATA RPS 0.9 l



Accessories for SATA® RPS™

Accessories for SATA RPS		
192195	SATA universal spray gun and gun hose holder	
40188	SATA universal gravity gun holder for gravity flow cups	
9886	SATA wall mounted gravity gun holder	
127852	Cleaning solution bottle 1.0 l	
EUV11 EUE11	Pressure pump spray bottle, 1.0 l with viton seal Pressure pump spray bottle, 1.0 l with EPDM seal	
127845	RPS 6-pack cup carrier	
139444	UV nozzle protectors, 5-pk	
165399	SATA RPS mix lid w/ 50 lids for RPS 0.6 l and 0.9 l (allows for stacking RPS cups)	
173435 117051	Shaker ring for the 0.03 l Shaker ring for 0.06 l and 0.09 l	

SATA® RPS™ Adapter

Manufacturer	Spray Gun	Adapter	Part No.
SATA	SATAjet 2000 HVLP, RP w/o QCC	2	125237
	SATAjet LM 2000 HVLP/RP, SATAjet 90	2	125237
	SATAjet KLC HVLP/RP, KLC P	2	125237
	SATAjet B, NR 92, NR 95 HVLP	1	125211
	SATAjet LM B 92	7	133595
	SATAminijet, minijet 2, 3, 4	10	135798
	SATAjet 1000 H	16	188292
	SATAminijet 1000 H	17	188318
Binks	MG-1	3	125252
Accuspray	Isaac	11	134080
Airgunsa	AZ40 HTE	4	125278
Asturo	OM Green	5	125294
3M/Graco	3M PPS	6	126326
DeVilbiss	PRI, GTI, GTI Pro, GFG, GFV, GFHV 510, Tekna, CVi, GFP	3	125252
	SRi	15	164608
	Starting Line HLVP Spray Gun	13	150136
	Finish Line/Starting Line Mini Spray Gun	14	150151
Dux	Gravity flow	7	133595
Emininet	E13	4	125278
IWATA	W 400, WR 400, LPA 94, VXL Primer Gun, LPH 400, LPH 440	1	125211
	LPH 80	19	193276
	LS-400 (Super Nova), W 300, LPH 300, WS 4000 (Super Nova)	4	125278
	LPH100-LVG	12	147272
	W 100, LPH 100 (no adapters available)	-	-
Kremlin	M 21 G	20	215079
NAPA	Ultra-Pro	1	125211
Optima	800, 900	8	133827
Pro-Tek	Pro-Tek	1	125211
Sagola	475 Mini-Gun	10	135798
	403 G, 433 G, 434 G, 444 G, 450 G, 4100 G, 4200 G, 4300, G Etreme	7	133595
	4400	1	125211
	4400/4500 Xtreme	18	188664
Sharpe	GT1, Platinum, Titanium, Cobalt, SGF 98, Razor primer	9	135111
	Finex FX 300	8	133827
Walcom	FX GEO, FX HVLP	5	125294

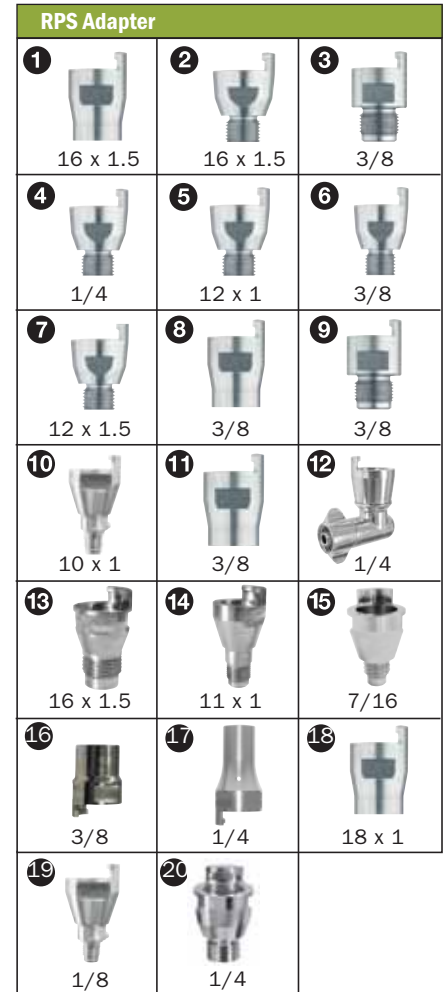

Technical modifications and printing errors reserved

SATA® RPS™ siphon kits and storage





Accessories for SATAjet H

188292	RPS Adapter No. 16 with QCC Connection thread G 3/8 To use for RPS siphon cup.	
188318	RPS Adapter No. 17 with QCC Connection thread G 1/4 To use for RPS siphon cup.	
188482	RPS Siphon Kit, pins, suction hose, sieve, (for 0.3L cup), pack of 25	
188516	RPS Siphon Kit, pins, suction hose, sieve, (for 0.3L cup), pack of 50	
188490	RPS Siphon Kit, pins, suction hose, sieve, (for 0.6L cup), pack of 25	
188524	RPS Siphon Kit, pins, suction hose, sieve, (for 0.6L cup), pack of 50	
188508	RPS Siphon Kit, pins, suction hose, sieve, (for 0.9L cup), pack of 25	
188532	RPS Siphon Kit, pins, suction hose, sieve, (for 0.9L cup), pack of 50	

SATA RPS Storage solutions

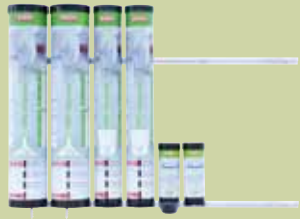











144840	RPS Depot Storage rack to hold up to three RPS cup boxes (RPS cups not included)	
--------	--	---









SATA® RPS™ Dispenser

SATA RPS Dispenser		
<p>All SATA RPS components have their defined place: cups, lids and sieves</p> <ul style="list-style-type: none"> ■ Allows to conveniently take out individual SATA RPS components ■ Filling level indication to ensure replenishment in due time ■ Re-filling is a swift process which only requires a quick removal of the tubes from the brackets 		
195784	<p>SATA RPS wall dispenser (basic kit) Standard kit for up to 2 cup sizes: 2 aluminum brackets for wall mounting, 2 tubes for cups, 2 tubes for lids, and 2 tubes for sieves</p>	
195776	<p>SATA RPS extension kit Extension kit for one additional cup size: each 1 tube for cups, 1 tube for lids, and one tube for the sieves (the brackets of the standard kit are suitable for mounting the extension kit)</p>	
196543	<p>SATA RPS rotawall adapter kit Compact wall-mounting version: Wall bracket with rotating spindle to mount the basic version* and the extension kit*</p>	
196550	<p>SATA RPS rotafloor adapter kit Workbench/floor version: Height-adjustable stand with floor plate and rotating spindle to mount the basic version* and the extension kit*</p>	

* not included in the scope of delivery

SATA® Gravity and Siphon Cups for Spray Guns

Gravity flow cup							
Gun type		SATAjet 5000 B, jet 4000 B, jet 3000 B, jet 1000 B, jet 100 B, jet 2000, jet RP, KLC, LM 2000 B	SATAjet B, jet GR, jet NR 95	SATAminijet 4400 B	SATAminijet 3000 B, minijet 1 - 4, jet 20 B	SATAjet 20 B Dekor 2000	Lid
Capacity	Order No.						
Reusable Plastic cup							
63 ml	15669				 use with adapter No. 129346		15909
63 ml	153551				 use with adapter No.129346		15909
85 ml QCC	165142	 use with adapter part no. 169326					95448
0.125 l QCC	125443						95448
0.125 l QCC	197541						199075
0.3 l	128470						121293
0.3 l QCC	120675						121293
0.6 l	49379						49395
0.6 l QCC	27243						49395

Gravity flow cup							
Gun type		SATAjet 5000B, jet 4000 B, jet 3000 B, jet 1000 B, jet 100 B, jet 2000, jet RP, KLC, LM 2000 B	SATAjet B, jet GR, jet NR 95	SATAminijet 4400 B	SATAminijet 3000 B, minijet 1 - 4, jet 20 B	Lid	
Capacity	Order No.						
Reusable aluminum cup							
0.15 l	125948					64022 Pk of 3	
0.15 l QCC	198911						
0.75 l	6601					71555 Pk of 3	
0.75 l QCC	137729						
1.0 l	46631						
1.0 l QCC	96685						

Spare Parts

SATA® Aluminum and PVC Gravity Flow Cups for Spray Guns



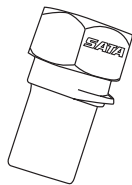
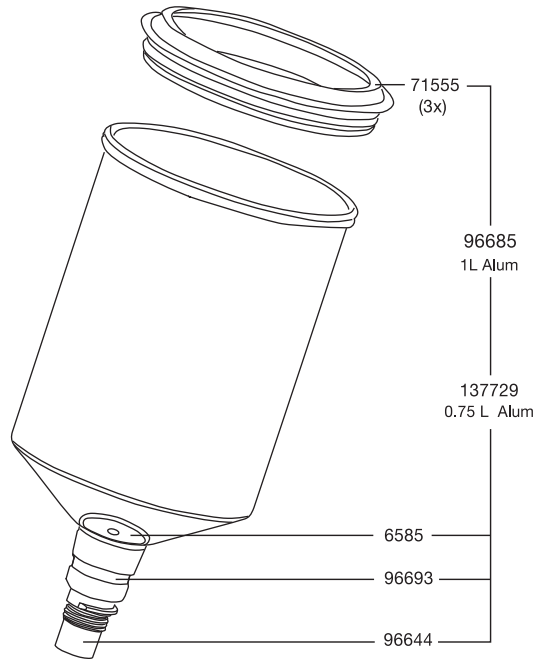
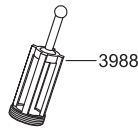
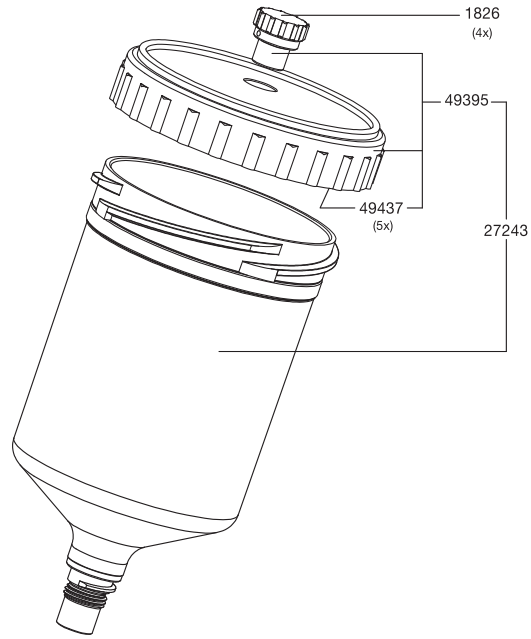









Part No. / Desc.	
1826	Non-drip device, pk of 4
3988	Sieve, pk of 10
6585	Insert, aluminum cup
27243	Cup, 0.6L QCC plastic, cpl
49395	Lid, 0.6L plastic
49437	Cup Lid Drip Ring, 0.6L, pk of 5
71555	Lid, plastic, pk of 3
96644	Nipple, QCC aluminum cup
96685	Cup, 1L QCC aluminum, cpl
96693	Ring, QCC marking
96719	Adapter, QCC to PPS cup
96875	Inner cup seal (not shown)
137729	Cup, 0.75 L alum, cpl



96719 QCC adapter, PPS
Full size

Technical modifications and printing errors reserved

SATA® Siphon Cups and Cup Adapters

Aluminum Siphon cup					
Gun type		SATAjet 1000 H, Satajet H, LM 2000 H, GR/H-92, LM/H92 std SATAjet/H NR-92, SATAjet/H NR-95			
Capacity	Order No.				
Reusable Aluminum Siphon cup					
1.0 l	2691				
Glass cups					
Gun type		SATAminijet 4400 B	SATAminijet 2, 3, 4 SATAminijet 3000 B	SATA dekor SATAjet 20 B	
Capacity	Order No.				
Side mount glass siphon cups					
25 ml plug-in cup, each	16295	X	X	X	
25 ml plug-in cup, pk of 5	53033	X	X	X	
25 ml plug-in cup, pk of 5 w/ QCC & threaded plug-in adapter	125963	-	X	X	
25 ml plug-in cup, pk of 5 w/ QCC plug-in adapter	200238	X	-	-	
25 ml blind cup, each	16386	X	X	X	
25 ml blind cup, pk of 5	58164	X	X	X	
Cup Adapters					
96719	QCC cup adapter for PPS cup, full size guns				
125955	Plug-in cup connection with QCC SATAminijet (3000 B and earlier) SATAjet 20 B (dekor) cup adapter, glass siphon cups				
200220	Plug-in cup connection with QCC (std size) SATAminijet 4400 B				
129346	2.2 fl oz. QCC cup adapter for SATAminijet 3000 B				
169326	3.0 fl. oz. QCC cup adapter for full size SATA guns				

SATA® BVD Pressurized Cup System

SATA BVD Pressurized Cup System

25775	SATA BVD 0.75 aluminum pressure gravity cup for SATA spray guns - male and QC threads on cup, complete with air control regulator. For SATAJet 3000, jet 2000 HVLP, Jet RP, Jet 1000, Lm 2000
57505	SATA BVD 0.75 aluminum pressure gravity cup for SATA spray guns - female threads on cup, complete with air control regulator. For SATAjet B and GR/B-92

Part No. / Desc.
8268 Sealing ring
20438 Safety pressure relief valve, BVD
20461 Plastic air hose for BVD and agitator cup
21014 Aluminum lid, complete
53777* Air connection for aluminum lid
54049 Sealing ring, (4x)
65920 Pressure regulator assembly
70664 Anti drip device, (10x)
83493 Connection for pressurize cup, complete
83501 Air hose cpl. dw/ pressurized cup connection for SATA Spray-Master
120816 Pressure release screws (2x)
133983 Air connection piece G1/4 thread
*please also order 8268

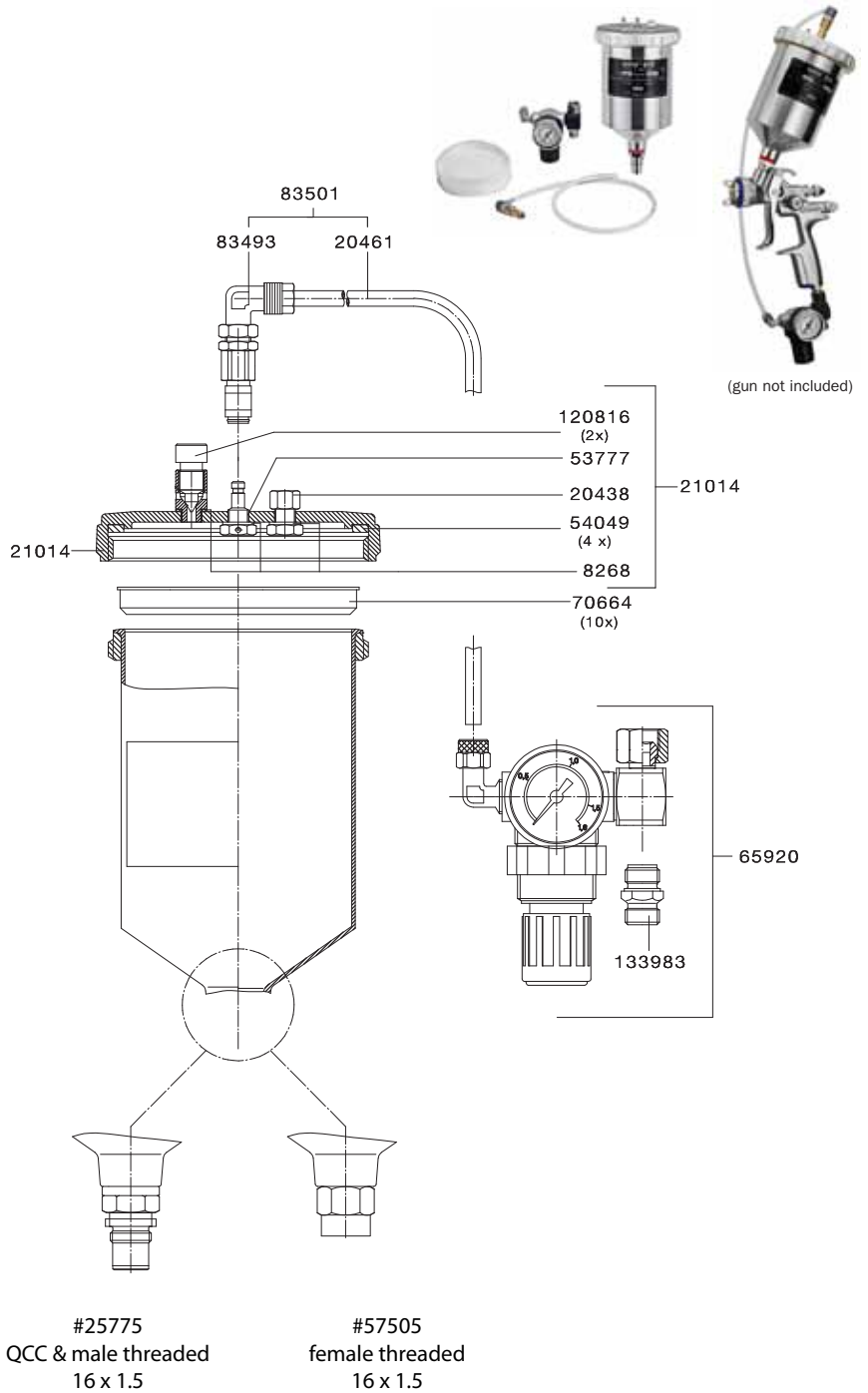

SATA® Agitator Cup

SATA agitator cup

9951	SATA agitator cup, female thread (on cup), 16 x 1.5, complete with regulator for SATAjet 3000, jet 2000 HVLP, Jet RP, jet 1000, LM 2000
29926	SATA agitator cup, QCC and male threads (on cup), 16 x 1.5, complete with regulator, for jet B, GR/B-92

Part No. / Desc.
1503 Countersunk screw M4 x 8 DIN 965, stainless steel, for micrometer round/flat spray control
1826 Anti-drip device (4x)
2188 Air control for agitator regulator
20412 Cup only w/o QCC connection
20461 Plastic air hose for BVD and agitator cup
21055 Agitating paddle for agitator cup
21063 Driving wing, cpl. with screw
21071 Gasket agitating vane, agitator cup
29678 Cup only w/ QCC connection
44735 Countersunk screw, M 2.5 x 5 DIN 965
44743 Control knob
44792 Spindle
53785 Angle screw socket, LCN-1/8-PL-4, f.
53793 Coupling with inner thread G 1/8 for SATA BVD
54049 Sealing ring (4x)
65557 Control knob
123513 Gauge only

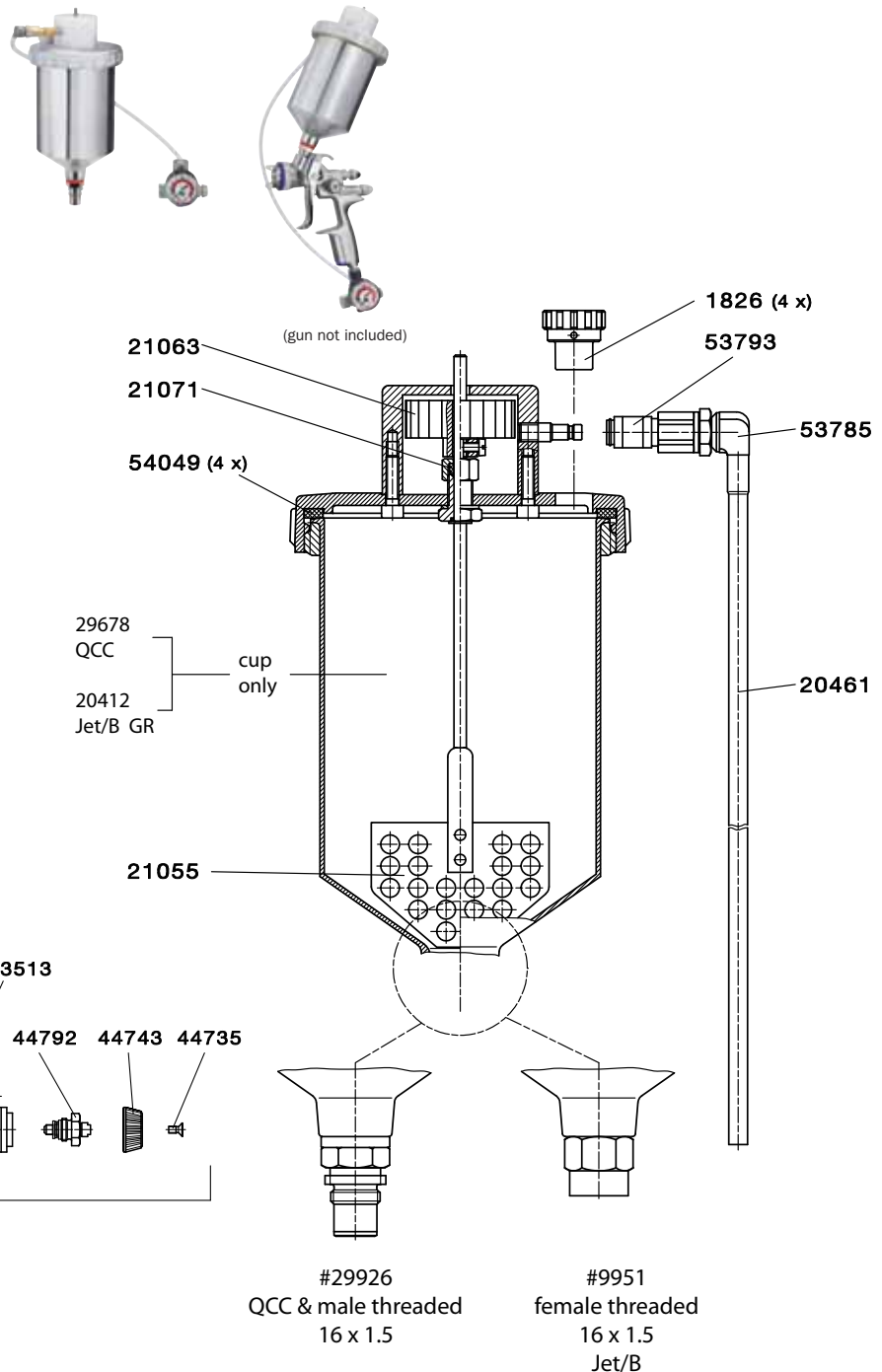

Breathing Protection



Breathing Protection with Activated Charcoal Belt Unit

Air-fed full hood for use with double stage filter regulators eg: SATA 444



Basic Version w/ Activated Charcoal Belt Unit

Hood

SATA vision 2000 hood with breathing hose connection



36384 Hood and charcoal belt unit

Belt Unit

Activated Charcoal Belt Unit



Required Accessories

Non-gassing air hose connection from filter to belt
Various sizes available, see page 147

CO Monitors page 146

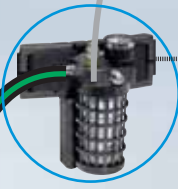

Optional Accessories for Breathing Protection with or without Activated Charcoal Belt Unit.

Optional Accessories

Breathing air warmer

Infinitely adjustable breathing air warmer
Order No. 61242



Breathing air humidifier

Breathing air humidification for a comfortable breathing climate
Order No. 89086



See pages 114-115 for connection options

Breathing Protection with Industrial Belt Valve



Air-fed full hood for use with triple stage filter regulators eg: SATA 484





Basic Version w/ Industrial Belt Valve

Hood SATA vision 2000 hood with breathing hose connection		60707 Hood and belt valve
---	---	------------------------------



Belt Unit Belt unit with industrial valve		
---	---	--

Required Accessories
 Non-gassing air hose connection from filter to belt
 Various sizes available, see page 147
 CO Monitors page 146

Basic Version w/ Activated Charcoal Belt Unit

Mask SATA air star C half mask with breathing hose connection		137554 Mask and charcoal belt unit
Belt Unit Activated Charcoal Belt Unit		

Basic Version w/ Industrial Belt Valve

Mask SATA air star C half mask with breathing hose connection		137570 Mask and belt valve
Belt Unit Belt unit with industrial valve		

Required Accessories
 Non-gassing air hose connection from filter to belt
 Various sizes available, see page 147
 CO Monitors page 146

SATA air star C breathing protection half mask





See pages 114-115 for connection options



SATA® vision™ 2000

Painting may generate excessive levels of overspray and solvent vapors. Some solvents cause poisonous toxic effects as they are absorbed into the bloodstream. Isocyanate hardeners are a specifically hazardous substance. The SATA vision 2000, Type C continuous flow supplied air respirator with a full face shield, provides complete protection for the eyes, skin and respiratory system.

The SATA vision 2000 NIOSH approval number is TC-19C-211. NIOSH approved respirators must be supplied with Type 1 Grade D air within the approved pressure range at the point of attachment of the respirator to the air delivery system. The activated charcoal belt unit is an auxiliary filter. Breathing air is filtered through activated charcoal. The activated charcoal purifies the air and removes any odor or hydrocarbon vapor. Airflow is controlled with a throttle valve. A pressure gauge is mounted on the belt unit to visually monitor correct pressure setting.

SATA vision 2000	
Technical Data	Require operating pressure: 4.0 bar / 58 psi
	Require minimum air volume flow: 170 NI/min, 6.2-11.3 cfm at 60-87 psi

Available versions		
51854	<p>SATA vision 2000 full hood respirator and full neck shield.</p> <p>Vision 200 hood is a type C continuous flow supplied air respirator with full face shield and adjustable headband. Painters with reasonable beard length, mustaches or eyeglasses will appreciate the full hood protection with wide field of vision and single pane, non-glare anti-static visor. The hood is hygienic due to easily replaced linings and sweatband. It also features a tip-up visor making it unnecessary for the painter to remove the hood between coatings.</p> <p>Scope of Supply: full face mask, hood cloth, PVC hose with air silencer/connection & 5 spare face shields</p>	
36384	<p>SATA vision 2000 hood with SATA activated charcoal filter</p> <p>Scope of Supply: SATA vision 2000 full face mask (#51854) SATA activated charcoal belt unit (#37200) T-connection set (#51110)</p> <p>NIOSH Approved</p>	
60707	<p>SATA vision 2000 hood with SATA industrial belt valve</p> <p>Scope of Supply: SATA vision 2000 full face mask (#51854) SATA industrial belt valve (#61002) * NOTE - T-Connection is not included - if required please order #51110</p> <p>NIOSH Approved</p>	

Belt Units		
37200	<p>SATA activated charcoal belt unit</p> <p>Breathing air is filtered through activated charcoal, which purifies the air and removes any odor or hydrocarbon vapor. Airflow is regulated with a throttle valve, and a gauge is mounted on the belt unit to visually monitor correct airflow setting.</p>	
61002	<p>SATA industrial belt unit</p> <p>This valve acts as an intermediary between the filtered air and the the full face mask. Airflow is regulated with a throttle valve, but does not include gauge. This unit does not filter air and must be used in conjunction with a triple stage filter (eg: SATA 484 Triple stage filter) or a fresh air ready filter</p>	
122341	<p>SATA industrial belt unit with T-connection</p> <p>This valve acts as an intermediary between the filtered air, the the mask, and the spray gun. Airflow is regulated with a throttle valve, but does not include gauge. This unit does not filter air and must be used with to be used in conjunction with a triple stage filter with an activated charcoal filter, (eg: SATA 484 Triple stage filter).</p>	

Spare Parts SATA® vision™ 2000

vision 2000 Hood Part No. 51854

Part No./Desc.	
10330	Sweat band, artificial leather, pk of 10
13854	Air silencer
21840	Visor pins, pk of 6
30270	Hose clamp
35050	Visor tear off sheet, pk of 50
35100	Visor tear off sheet, pk of 100
35659	Visor tear off sheet, pk of 5
35675	Visor tear off sheet, pk of 25
36301	Visor tear off sheet, pk of 1000
47571	Sweat band, artificial leather, ea
56184	Foam sleeve, only
56192	Air hose with foam sleeve
60541	Hood/chest cloth, gray, anti-static
61226	Headband, natural sheep leather, ea.
69658	White lining, pk of 20
75358	SATA hood cleaner, pk of 10
76299	Headband foam strip, w/adhesive
82594	Head piece with Velcro
89243	Adjusting assembly, headband
89250	Headband, complete
89268	Nut assembly, headband
89276	Visor frame, complete
138735	Pivot, headband adjusting, pk of 10

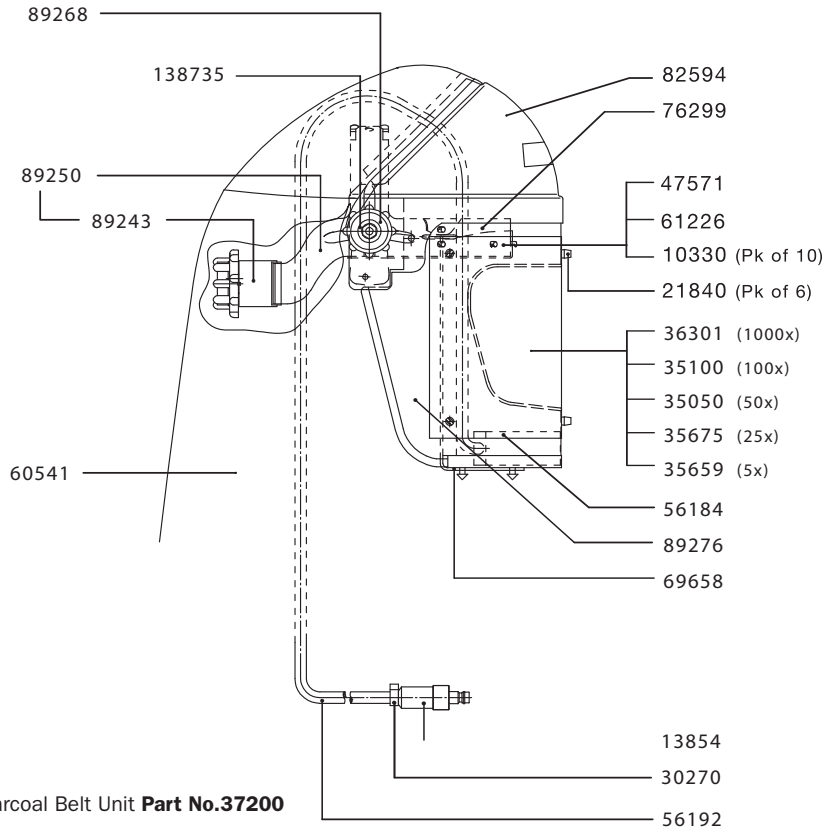

Charcoal Belt Unit Part No. 37200

Part No./Desc.	
13904	Charcoal filter cartridge
13920	Waist belt only, no cushion
15412	Belt unit support straps (not shown)
22947	O ring, housing
25171	Regulating valve, vision 2000
37523	Gauge, vision 2000
49726	Protective filter cover
51110	T-Connection Kit, charcoal belt unit
51656	T-Connection only, charcoal belt unit
53934	Quick coupling
53942	Nipple
66852	Filter cover
149872	Belt cushion only

Charcoal Belt Unit Part No. 37200

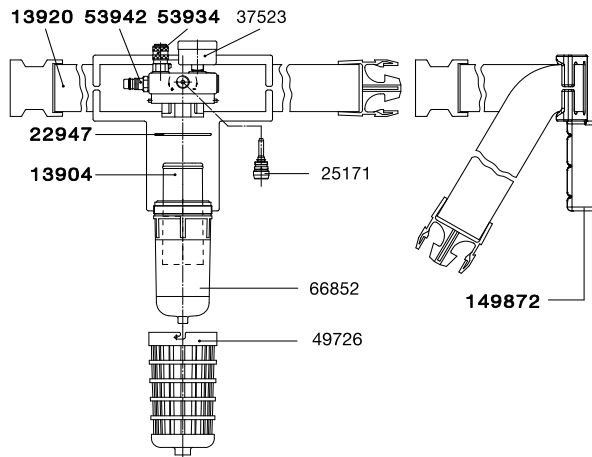

Industrial belt valve Part No. 61002

Part No./Desc.	
1503	Air control screw
13623	Female QC coupler
13656	Female threaded nipple
13920	Waist belt
51110	T fitting: Includes t-piece(516956), nipple (53942) & coupler (13599)
53934	Nipple, 1/4 male
54221	Fan control
54908	L Bracket
65557	Knob, fan control
149872	Belt cushion only, foam

Industrial belt valve Part No. 61002

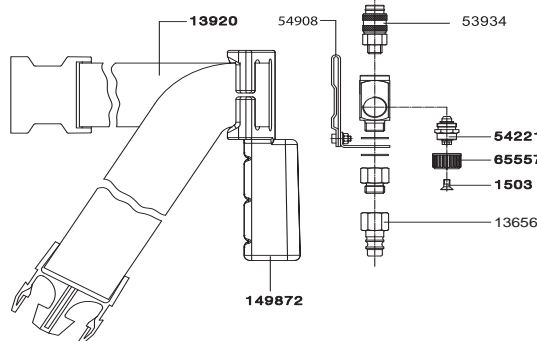

Industrial belt valve Part No. 122341

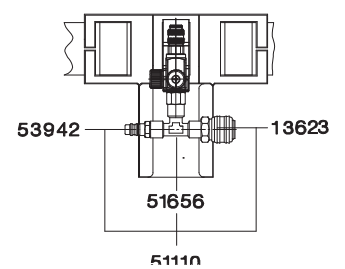

SATA® air star C™





SATA air star C™ half mask; NIOSH approval number TC-19C-210. NIOSH approved respirators must be supplied with Type 1 Grade D air within the approved pressure range at the point of attachment of the respirator to the air delivery system. A built-in indicator strip on the activated charcoal version changes color to a dark blue as the activated charcoal becomes saturated with oil or moisture. Airflow is regulated with a throttle valve and, on the activated charcoal version, airflow can be monitored with a gauge that is mounted on the belt unit. The SATA air star C does not have to be form fit.

SATA air star C



Technical Data

Required operating pressure: 58 psi
Require minimum air volume flow: 5 cfm
Maximum air volume flow: 11 cfm

Available versions

137588	<p>SATA air star C</p> <p>The SATA air star C is a ventilated half-mask with adjustable continuous fresh-air supply. Body of mask made of natural rubber with anatomic formed sealing frame and matching nose seating. Built in exhaustion valve. The SATA air star C half mask provides excellent vision with no internal heat buildup or moisture. The SATA air star C half mask offers a perfect face fit with four-point fixed head straps for seating the mask safely.</p> <p>Scope of Supply: full face mask, hood cloth, PVC hose with air silencer/connection & 5 spare face shields</p>	
137554	<p>SATA air star C with SATA activated charcoal filter</p> <p>Scope of Supply: SATA air star C half mask (#137588) SATA activated charcoal belt unit (#55798)</p> <p>NIOSH Approved</p>	
137570	<p>SATA air star C with SATA belt valve and T-connection</p> <p>Scope of Supply: SATA air star C half mask (#137588) SATA belt valve with t-connection (#122341)</p>	
137570	<p>SATA air star C with SATA belt valve</p> <p>Scope of Supply: SATA air star C half mask (#137588) SATA belt valve (#61002)</p>	

Belt Units

55798	<p>SATA activated charcoal belt unit</p> <p>Breathing air is filtered through activated charcoal, which purifies the air and removes any odor or hydrocarbon vapor. Airflow is regulated with a throttle valve, and a gauge is mounted on the belt unit to visually monitor correct airflow setting.</p>	
61002	<p>SATA industrial belt unit</p> <p>This valve acts as an intermediary between the filtered air and the the half mask. Airflow is regulated with a throttle valve, but does not include gauge. This unit does not filter air and must be used in conjunction with a triple stage filter (eg: SATA 484 Triple stage filter) or a fresh air ready filter</p>	
122341	<p>SATA industrial belt unit with T-connection</p> <p>This valve acts as an intermediary between the filtered air, the the mask, and the spray gun. Airflow is regulated with a throttle valve, but does not include gauge. This unit does not filter air and must be used with to be used in conjunction with a triple stage filter with an activated charcoal filter, (eg: SATA 484 Triple stage filter).</p>	

Spare Parts SATA® air star C™

SATA air star C Part No. 137588

Part No./Desc.	
120469	Hose assembly, complete
120477	Air distribution foam, Pack of 2
134254	Head straps
134270	5-pk exhalation diaphragms + 10-pk inhalation diaphragms
137612	2-pk connections

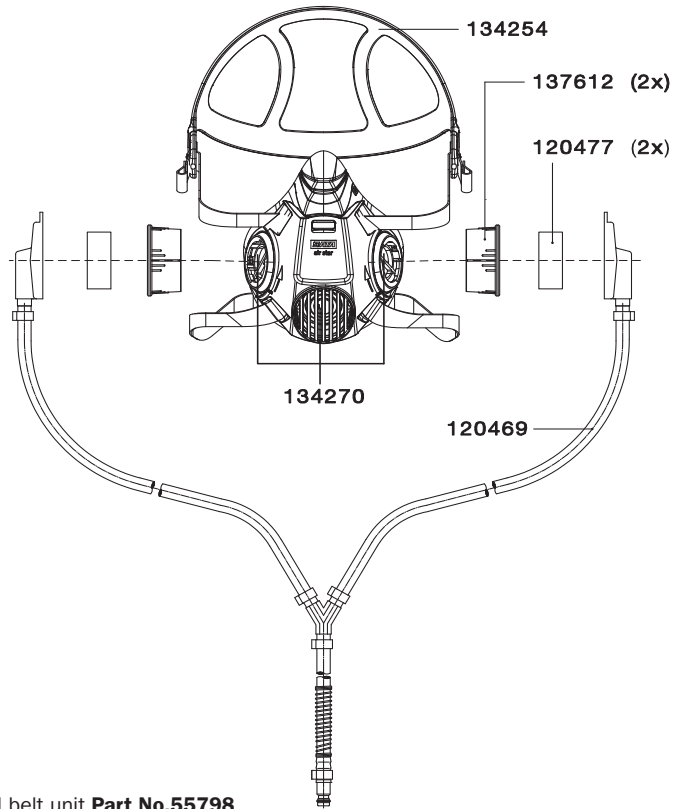

Charcoal belt unit Part No.55798

Part No./Desc.	
13904	Charcoal filter cartridge
13920	Waist belt
15412	Belt unit support straps (not shown)
22947	O ring, housing
25155	Regulating valve
37507	Gauge, air pressure, HM belt unit
49726	Cover, protective filter
51110	T-Connection Kit, charcoal belt unit
51656	T-Connection only, charcoal belt unit
53942	Nipple, 1/4 male hi-flow
66852	Filter cover
75176	Quick coupling, half mask
149872	Belt cushion only

Charcoal belt unit Part No.55798

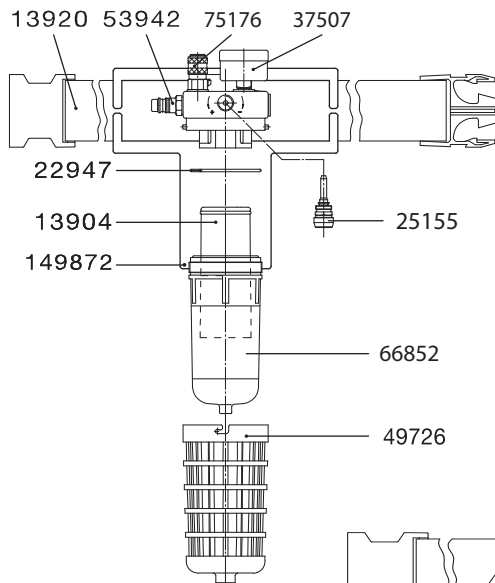

Industrial belt valve Part No. 61002

Part No./Desc.	
1503	Air control screw
13623	Female QC coupler
13656	Female threaded nipple
13920	Waist belt
51110	T fitting: Includes t-piece(516956), nipple (53942) & coupler (13599)
53934	Nipple, 1/4 male
54221	Fan control
54908	L Bracket
61002	Belt valve complete, vision 2000
65557	Knob, fan control
149872	Belt cushion only, foam

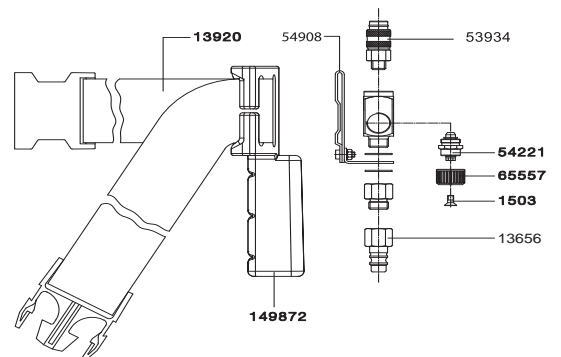
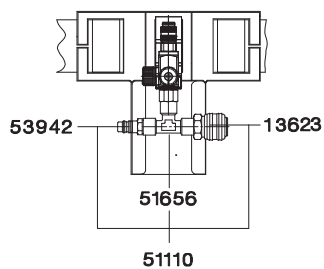

Industrial belt valve Part No. 61002

Industrial belt valve Part No. 122341





Accessories for Vision 2000/Air star C, Top air humidifier

Accessories for Belt Units

13904	Activated charcoal filter cartridge for both full and half mask belt units. To be replaced every 3 months	
15412	Belt unit support straps, suspenders	





Accessories for all supplied air respirators

89086	SATA top air breathing humidifier	
81158	Complete cartridge module for SATA top air humidifier	
61242	SATA air warmer with air micrometer for SATA respirators	

Cleaning Cloths

75358	10-pk disinfecting tissues for SATA respirators	
-------	---	---

Accessories for SATA vision 2000

60541	Hood cloth only, gray industrial, for SATA vision 2000, with neck and chest protection	
35659	Tear off visor sheets, vision 2000, pack of 5	
35675	Tear off visor sheets, vision 2000, pack of 25	
35050	Tear off visor sheets, vision 2000, pack of 50	
35100	Tear off visor sheets, vision 2000, pack of 100	
36301	Tear off visor sheets, vision 2000, pack of 1000	
69658	Hygienic hood lining, vision 2000, pack of 20	
10330	Head band lining, artificial leather, vision 2000, pack of 10	

Spare Parts SATA® top air™

SATA top air 2011 to present

Part No./Desc.	
24505	Safety quick coupling
24612	Nipple
24919	O ring, module
24950	Safety valve, complete
46169	Threaded nipple
53975	Hose clamp, 10.5
63214	Screw, filling cap
70789	O ring, filling cap
72611	Valve, complete
81158	Cartridge
82917	Air hose
86777	Head
86785	Receptacle
97311	Hose, PVC (cut to length)
163535	Holder
163543	Container with acme thread
176420	O-Ring 68 x 2.0 (before July 2013)

SATA top air pre- 2011

Part No./Desc.	
24620	Head gasket
70789	O ring, filling cap
82917	Air Hose
86777	Head NLA
86785	Receptacle NLA

SATA air warmer

Part No./Desc.	
1503	Screw, fan control
11551	O Ring
29413	Stainless steel nipple
53934	Safety quick coupling
65557	Knob, fan control

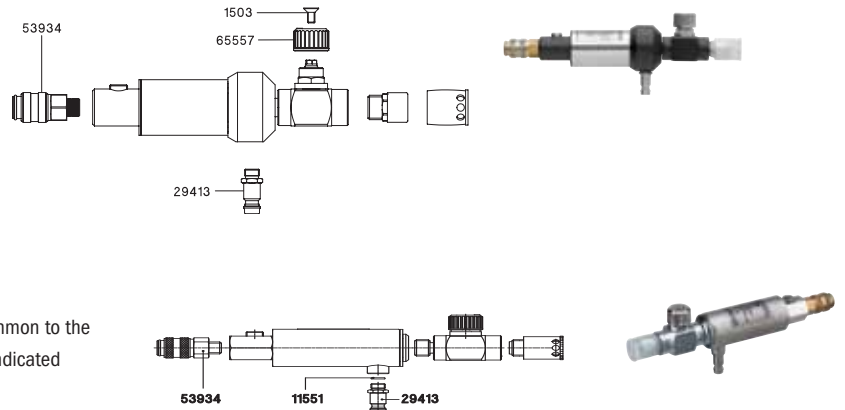
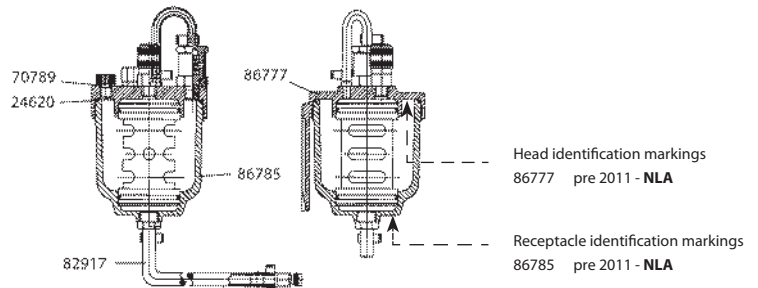
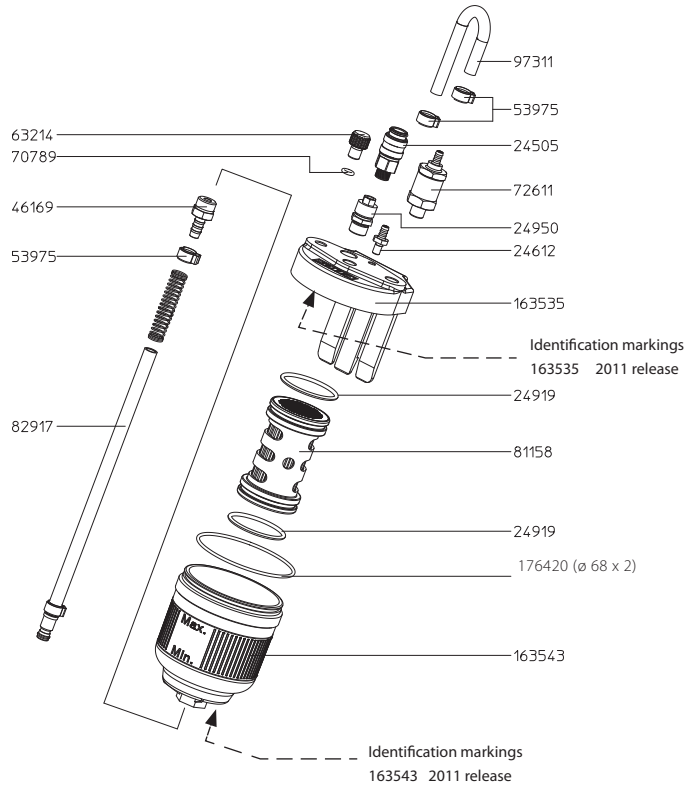

All other parts are common to the newer version if not indicated

Fittings and Connections for Respirators & Belt Units

SATA Fresh air systems require additional fittings from what is included in the scope of supply.

Please acknowledge that these are only general guidelines for basic SATA system set ups, and may differ based on shop equipment, painter preference, and alternate equipment lines.

All SATA filter units have 1/4" male threads on the outlet modules.

Female QC Coupler required to attach to outlet modules
2 x Part #13599

All Eurotech air hoses have 1/4" male threads on both ends
1 x Part #13656
 (to connect air hose to outlet module)
1 x Part #13599
 (to connect air hose to belt unit)



Fittings Checklist

4 x	13599	SATA QC female coupler
	① 2 x	For each outlet module drop on any SATA Filter unit.
	② 1 x	To connect air hose to SATA belt unit
	③ 1 x	To connect whip hose to spray gun
3 x	13656	SATA QC female Nipple
	④ 1 x	To connect air hose to outlet module.
	⑤ 1 x	To connect belt unit to 52" whip hose
	⑥ 1 x	For air inlet of spray gun

Fittings Checklist

1 x	3366-35	Eurotech Non-Gassing Hose
	⑦ 1 x	To connect filter unit to belt unit <i>Various length & sizes available, see Hose section for options.</i>
1 x	55640	Eurotech 52" Paint Whip Hose
	⑧ 1 x	To connect belt unit to spray gun
Optional		
1 x	51110	SATA T-Connection Kit
	⑨	If painter wishes to split air at belt unit and purchased a unit that does not include the T-Piece. <i>See Mask pages for scope of supply to confirm.</i>

NOTE - Alternate configurations of fittings, hoses and equipment is possible. Please accept this as a guideline for standard set ups of SATA fresh air systems.

Fittings and Connections for Respirators & Belt Units



All SATA belt units (with or without T-Connection) come with one QC Nipple connection.





All SATA vision 2000 full face mask, or half mask connects directly to the belt units with a small QC connection.

T-Connection is required if the painter wishes to paint from the air supplied at the belt unit.
T-Connection sold with all Activated Charcoal Belt Units



Please note - Image is shown with SATA vision 2000 full face respirator. These guidelines are also applicable to SATA air star C supplied air respirator



Alternate belt unit options also apply to these recommendations.

SATA HVLP Fittings		
13656	SATA HVLP female nipple G 1/4 female thread (Use #6981 for 5-pack)	
53942	SATA HVLP male nipple G 1/4 male thread	
13599	SATA HVLP female QC G 1/4 female thread	
13623	SATA HVLP male QC G 1/4 male thread	



SATA® air star F™



Filtering mask for short usage periods during small paint jobs

SATA air star F		
134353	SATA air star F, filter A2:P3 R D, 2 pre-filter holders and 10 pre-filters	
134288	SATA air star F, filter A2:P3 R D, 2 pre-filter holders and 10 pre-filters with hygiene box	

Accessories		
75358	10-pk disinfecting tissues for SATA respirators	

Spare Parts for SATA air star F		
134262	10-pk pre-filters for SATA air star F	
134239	50-pk pre-filters for SATA air star F	
134296	1 pair special filter A2:P3 R D for SATA air star F	
134312	3 pair special filter A2:P3 R D for SATA air star F	
134304	6 pair special filter A2:P3 R D for SATA air star F	
134247	2 pre-filter holders (red) and 10 pre-filters for SATA air star F	

Spare Parts SATA® air star F™

Part No./Desc.	
134239	50-pk pre-filters
134247	2 pre-filter holders (red) and 10 pre-filters
134254	Head straps
134262	10-pk pre-filters
134270	5-pk exhalation diaphragms, 10-pk inhalation diaphragms
134296	1 pair special filter A2:P3 R D
134304	6 pair special filter A2:P3 R D
134312	3 pair special filter A2:P3 R D

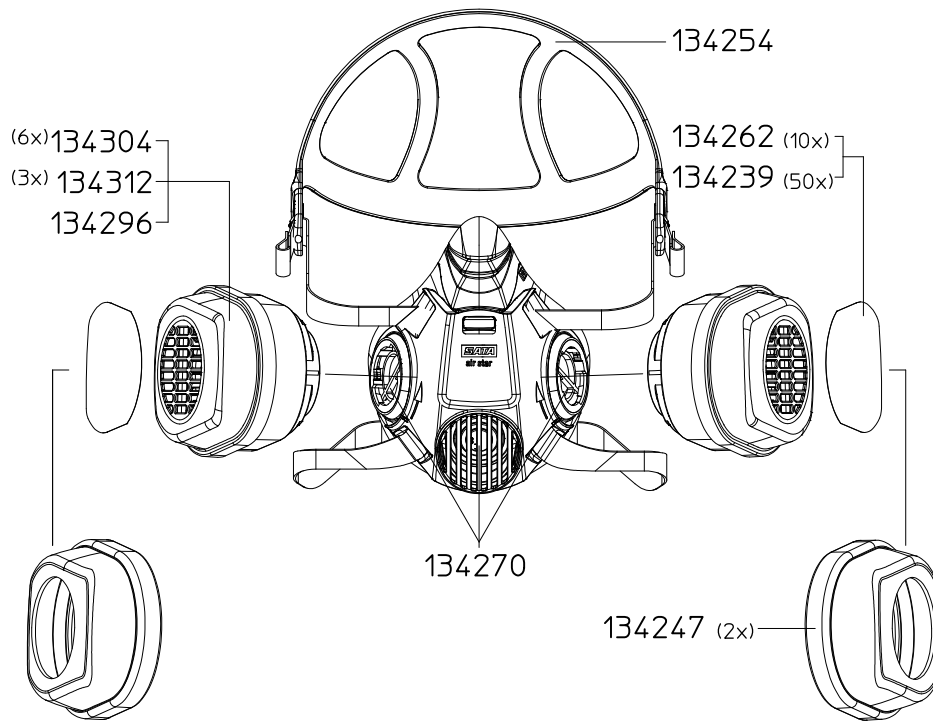



Filtration







SATA® filter 414™ / 424™ / 434™ / 464™





SATA filter 414/424/434/464

Technical Data	
	Air inlet: G1/2, female thread
	Air outlet: G1/2, female thread
	Max. inlet operating pressure: 15.0 bar / 217 psi
	Max. outlet operating pressure: 10.0 bar / 145 psi
	Air flow at 6.0 bar: 3,600 NI/min / 129 cfm @ 90 psi
	Max. ambient temperature: 120° C
	Max. ambient temperature w/ activated charcoal: 60° C



Pressure Regulator/water separator

92288	SATA 420 Line Pressure Regulator High air volume of 141 cfm, up to 225 psi, inlet & outlet G 1/2 female thread	
92213	SATA filter 414 5 µ oil / water separator with automatic condensation discharge, with ball valve air connection module but without regulator. 1/2 inch internal inlet thread and two outlet module drops. (2 x G 1/4 male thread)	
92254	SATA filter 414L (in-line) 5 µ oil / water separator with automatic condensation discharge, without ball valve air connection module and regulator for in-line installation. 1/2 inch internal inlet/outlet thread. (G 1/2 female thread)	
92221	SATA filter 424 5 µ oil / water separator unit with automatic condensation discharge, pressure regulator and ball valve air connection module. 1/2 inch internal inlet thread and two outlet module drops. (2 x G 1/4 male thread)	
92262	SATA filter 424 L (in-line) 5 µ oil/water separator unit with automatic condensation discharge and pressure regulator. Does not include ball valve air connection module. 1/2 inch internal inlet/outlet thread.	

Fine filter

92239	SATA filter 434 0.01 µ micro-fine filter unit with ball valve air connection module. Provides 99.998% clean air. Compressed air must be pre-filtered when using this unit. 1/2 inch internal inlet thread and two outlet module drops. (2 x G 1/4 male thread)	
92270	SATA filter 434L (in-line) 0.01 µ micro-fine filter unit without ball valve air connection module. Provides 99.998% clean air. Compressed air must be pre-filtered when using this unit. 1/2 inch internal inlet/outlet thread.	

Activated charcoal filter to retrofit SATA filter 444

92247	SATA filter 464 Single-stage activated charcoal filter without pressure regulator, with outlet module drops (2 x G 1/4 male thread)	
141473	SATA filter 464 Add-on Activated Charcoal unit with fittings without module	
92247L	SATA filter 464L (in-line) Line filter unit without fitting and module. Used to convert a filter 444 to a 484	

Spare Parts SATA® filter 414™ / 424™ / 434™ / 464™

Part No./Desc.	
2923	Spring
2949	Diaphragm
15511	Auto. condensate valve only
22046	Pressure gauge 2nd stage
22087	"O" ring
22137	Cyclone tube
22160	Sintered bronze filter
23804	Pressure valve, complete
24471	PVC nut with "O" rings
24489	Mounting rod with pressure valve
24521	Baffle with "O" ring
24554	Housing tube with auto. cond. valve
24562	Adapter with "O" ring
28506	"O" ring
28514	"O" ring
59295	Outlet manifold, std
73890	Threaded rod
80457	Spindle, complete
81810	Fine filter
83113	Fixing nut
84749	"O" ring, 33 x 2
84871	Housing Tube, 2nd Stage
85142	"O" ring, 30 x 1.5
85373	Activated charcoal cartridge
94979	Repair kit, 400
95000	Union fitting, 1/2"
95851	Countersunk screw
96750	Packing Kit
96883	Regulator adjusting knob
158808	Manifold, 2 drop

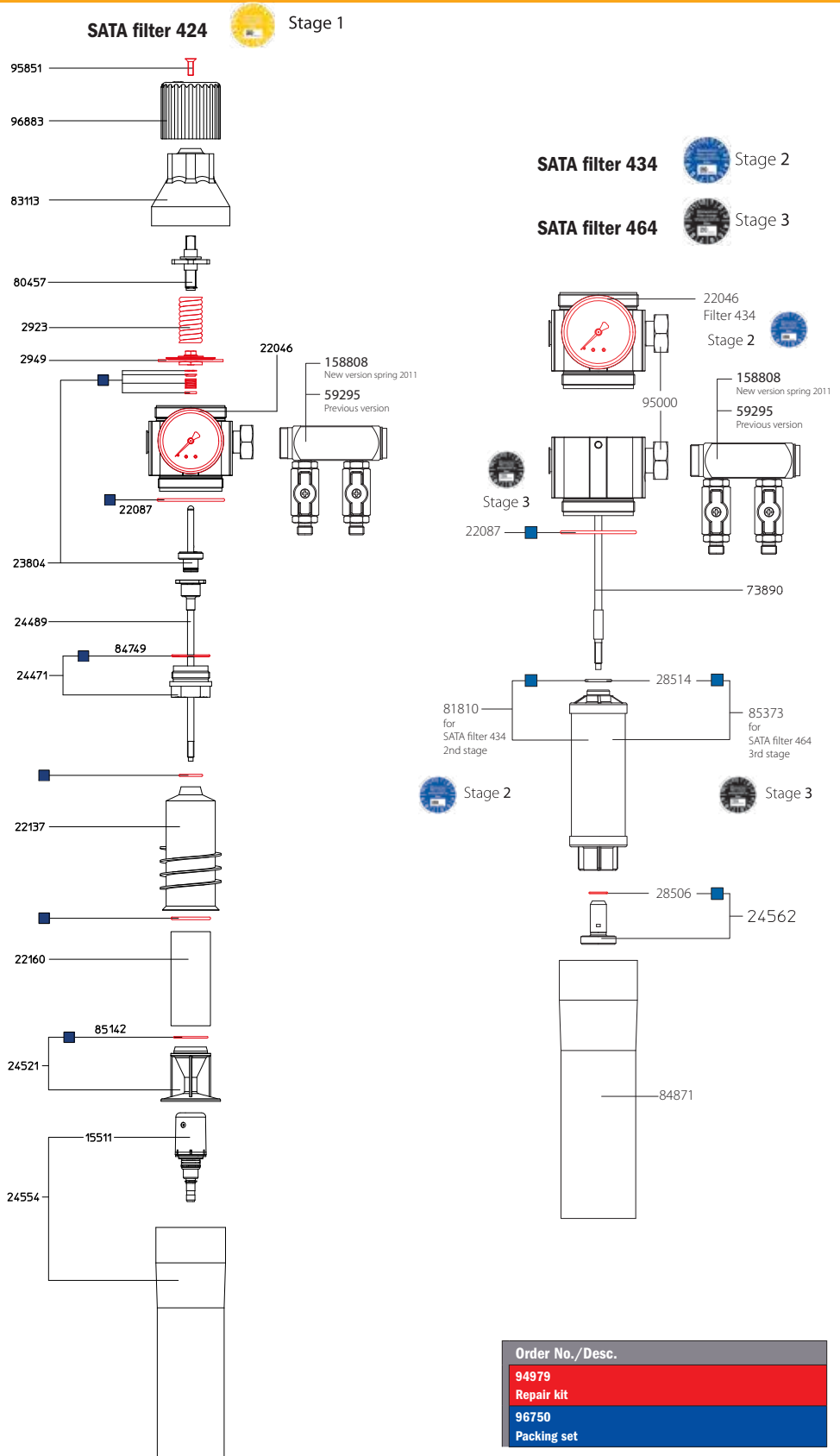

Order No./Desc.
94979 Repair kit
96750 Packing set

Technical modifications and printing errors reserved

SATA® filter 444™/ 474™/ 484™

The SATA 400 modular filter series is designed to meet the highest standards of quality and performance. The modular system allows the user to adapt to varying shop conditions and requirements. Easy to service and maintain with no desiccant related problems. Dual gauges monitor pressure differential, thus a pressure variation of 10 to 15 psi or more indicate filter maintenance is required. Fully automatic condensation discharge, and corrosion resistant with rugged metal housing for long service life.



SATA filter 414/424/434/464

Technical Data	
	Air inlet: G1/2, female thread
	Air outlet: G1/2, female thread
	Max. inlet operating pressure: 15.0 bar / 217 psi
	Max. outlet operating pressure: 10.0 bar / 145 psi
	Air flow at 6.0 bar: 3,600 NI/min / 129 cfm @ 90 psi
	Max. ambient temperature: 120° C
	Max. ambient temperature w/ activated charcoal: 60° C

Combination Filter

92296	SATA filter 444 Double-stage sinter filter/fine filter with pressure regulator and outlet module drops (2 x G 1/4 male thread)	
92833	SATA filter 444 w/ floor stand	
28076	Floor stand only	
92296L	SATA filter 442 (in-line) Double-stage sinter filter/fine filter without pressure regulator, without outlet module drops (G 1/2 female thread)	
92312	SATA filter 474 Double-stage fine filter/activated charcoal without pressure regulator, with outlet module drops (2 x G 1/4 male thread)	
92320L	SATA filter 482 (in-line) In-line version of the SATA 484 three stage filter unit. No regulator or outlet module drops. 1/2 inch internal inlet and outlet threads	
92320	SATA filter 484 Triple-stage sinter filter/fine filter/activated charcoal filter w/ pressure regulator & outlet module drops (2 x G 1/4 male thread)	
129619	SATA filter 484 w/ floor stand (not shown)	
173195	SATA filter 484 mobil Triple-stage sinter filter/fine filter/activated charcoal filter w/ pressure regulator, outlet module drops (2 x G 1/4 male thread), integrated into case body and paint whip hose, in secure aluminum travel case with wheels and pull.	

Spare Parts SATA® filter 444™ / 474™ / 484™

Part No./Desc.	
2923	Spring
2949	Diaphragm
15511	Auto condensate valve only
22046	Pressure gauge
22087	"O" ring
22137	Cyclone tube
22152	"O" ring
22160	Sintered bronze filter
23804	Pressure valve, complete
24471	PVC nut with "O" rings
24489	Mounting rod with pres. valve
24521	Baffle with "O" ring
24554	Housing tube with auto. cond. valve
24562	Adapter with "O" ring
28506	"O" ring
28514	"O" ring (included with filter elements)
59295	Outlet manifold, std
73890	Threaded rod
78360	Seal
80457	Spindle, complete
81810	Fine filter
83113	Fixing nut
84749	"O" ring, 33 x 2
84871	Housing Tube, 2nd Stage
85142	"O" ring, 30 x 1.5
85373	Activated charcoal cartridge
92163	Mounting bolt, 0/400
92569	Wall mounting kit
94979	Repair kit, 400
95000	Union fitting, 1/2"
95851	Countersunk screw
96883	Regulator adjusting knob
158808	2 drop manifold, 2011 and after

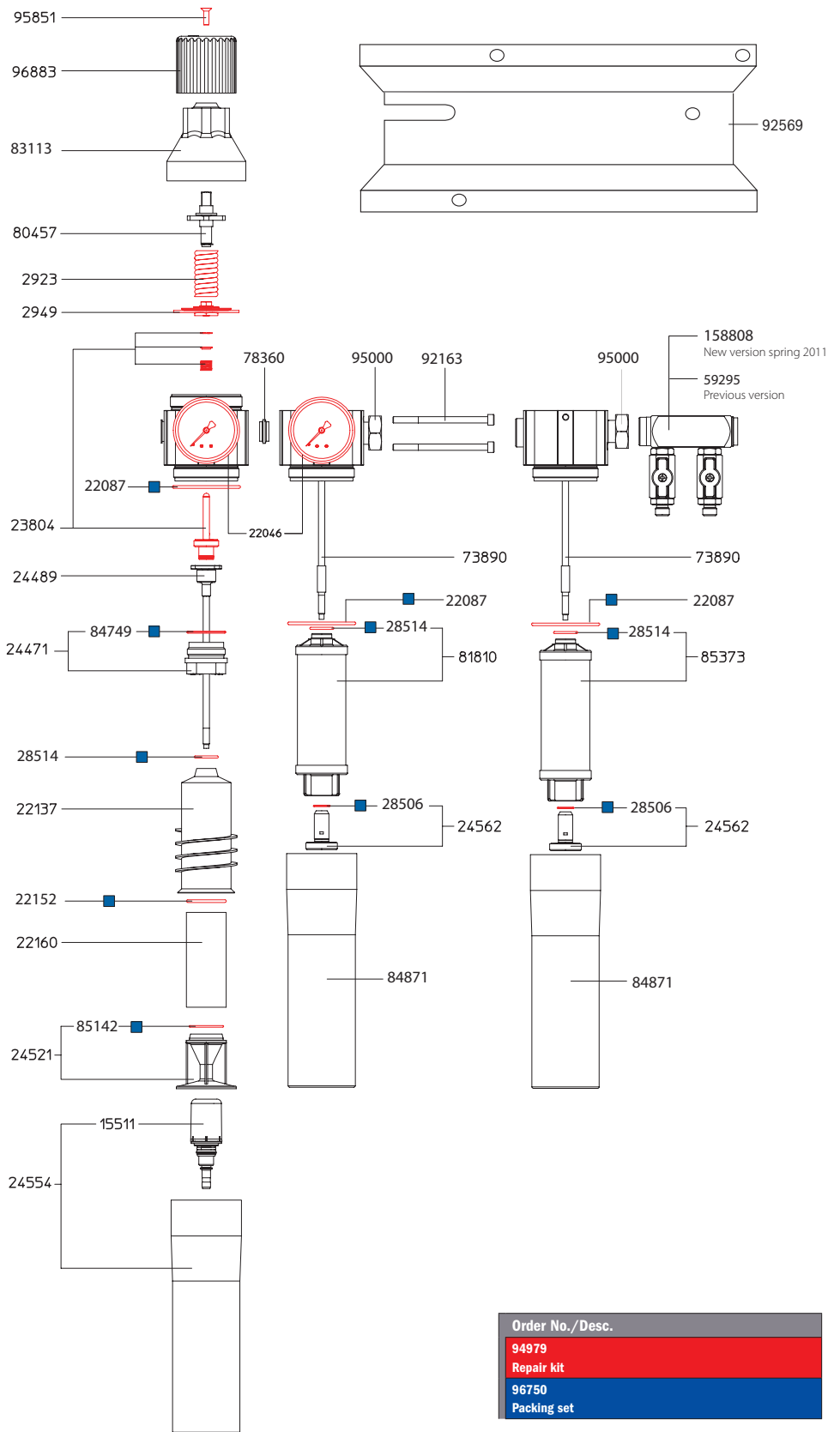

Order No./Desc.
94979
Repair kit
96750
Packing set

Technical modifications and printing errors reserved

SATA® filter 222™/242™/ 244™/ 284™



Along with the 400, the 200 filter series is the most versatile modular filter system currently on the market but at an unbeatable price. The 200 is rated at 72 cfm @ 90 psi, more than adequate for many small shops. It can be connected to compressed air pipes from either the right or left side. When atomized air leaves the spray gun, it must be clean, dry and free of condensation, silicone, oil or any other contamination.



SATA filter 200 series

Technical Data	Air inlet: G1/2 i, female thread
	Air outlet: G1/2 i, female thread
	Max. operating pressure: 10 bar / 145 psi
	Max. ambient temperature: 120 ° C
	Air flow rate: 72 cfm @ 90 psi

SATA 200 series

141226	SATA filter 264 - Activated Charcoal Filter Activated charcoal unit removes oil vapor and organic odors. Pre-filtering compressed air is required. Suitable as an add-on unit to existing SATA 2-stage filter units.	
43687	SATA filter 222 - Water/Oil Separator Single-stage sinter filter with pressure gauge, automatic condensate discharger, w/o regulator (G 1/2 female thread), filters air down to 5 µ. For use as an unregulated line filter	
43752	SATA filter 242 (in-line) - Double Stage Filter Unit Double-stage sinter filter/fine filter with pressure regulator for air installation (G 1/2 female thread) Use as an unregulated line filter for very fine particle separation Filters down to 0.01 µ	
44404	SATA filter 244 - Double Stage Filter Unit Double-stage sinter filter/fine filter with pressure regulator and 2 drop manifold outlet module Use to connect regulated air to air tools and breathing air	
189290	SATA filter 282 (in-line) - Triple Stage Filter Unit An economical in-line three-stage filter unit. Stages include a 5 micron filter with automatic condensation discharger, a 0.01 micron fine filter and an activated charcoal filter for breathing air or spraying water borne materials. No outlet modules included.	
141218	SATA filter 284 - Triple Stage Filter Unit Triple-stage sinter filter/fine filter/activated charcoal with pressure regulator and outlet module Used in conjunction with the SATA supplied air respirator industrial belt valve or ensuring removal of oil residue for spraying water borne paint	

Spare Parts SATA® filter 222™/242™/ 244™

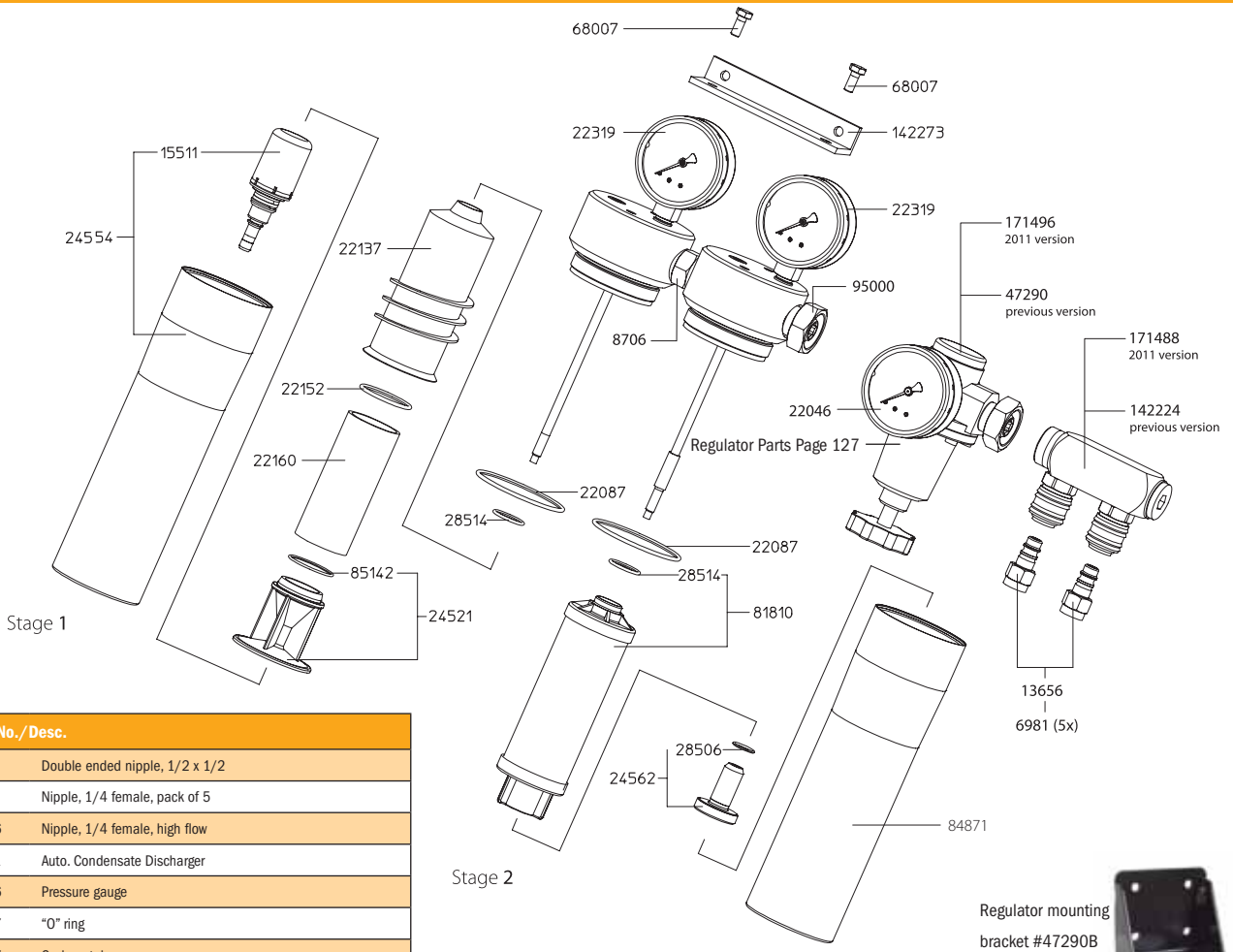

Part No./Desc.	
8706	Double ended nipple, 1/2 x 1/2
6981	Nipple, 1/4 female, pack of 5
13656	Nipple, 1/4 female, high flow
15511	Auto. Condensate Discharger
22046	Pressure gauge
22087	"O" ring
22137	Cyclone tube
22152	"O" ring
22160	Sintered bronze filter
22319	Pressure gauge, 134, 334
24521	Baffle with "O" ring
24554	Housing tube with auto. cond. dis.
24562	Adapter with "O" ring
28506	"O" ring,
28514	"O" ring
37622	Fixing angle, single filter
47290	Pressure regulator with gauge previous to 2011
68007	Hex screw, M6x14
81810	Fine filter, 134, 334
84871	Housing tube, 2nd and 3rd stage
85142	"O" ring 30 x 1.5 300
85357	Housing spanner wrench (not illus.)
85373	Activated charcoal filter w/O-ring
95000	Union fitting
142224	Outlet manifold w/QC couplings and nipples, previous version
142273	Fixing angle, double filter
171488	Outlet manifold w/QC couplings and nipples, 2001 ver.
171496	Pressure reg. with gauge, 2011 ver

SATA Filter 264

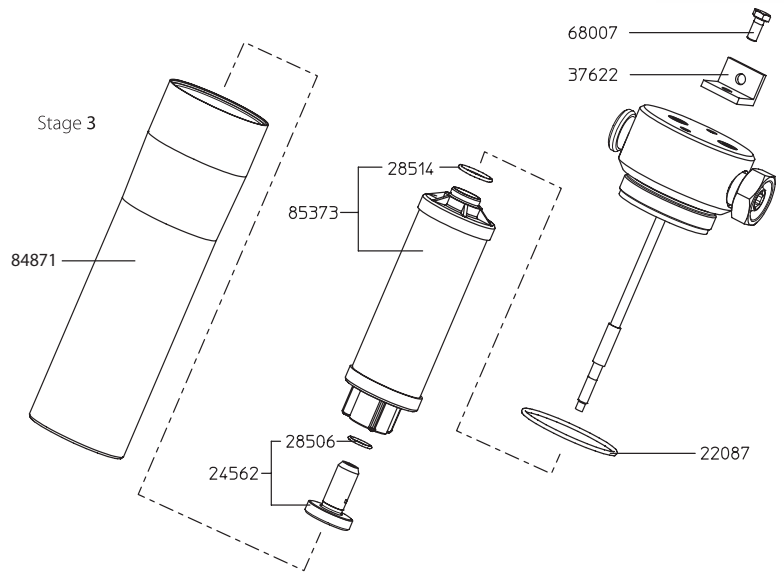











Order No./Desc.
90993
Repair kit

Technical modifications and printing errors reserved

Accessories for SATA® filter series

SATA Filter cartridges		
22160	Sinter filter for SATA filter series 200, 300, 400	 stage 1
81810	Fine filter cartridge for SATA filter series 200, 300, 400	 stage 2
85365	Ultra fine filter	
85373	Activated charcoal cartridge for SATA filter series 200, 300, 400	 stage 3
SATA service kit for filter cartridges: In handy storage case		
138933-12	1 st & 2 nd Stage (22160 & 81810)	
138933-23	2 nd & 3 rd Stage (81810 & 85373)	
138933-123	1 st 2 nd & 3 rd Stage (22160, 81810, 85373)	
SATA Filter accessories		
59295	400 Series Manifold - 2 drop Pre- 2011	
158808	400 Series Manifold - 2 drop Post- 2011	
158824	Manifold for 494 filter middle module only	
171488	Manifold, 2 drop, 200 series w/ coupler and nipple	
171496	Pressure regulator, 200 series Post- 2011 version	
47290	SATA Pressure Regulator 1/2" connection Max. inlet pressure 140 psi Before 2011 version	
142224	200 Series manifold with couplings nipples, 1/2" connection Pre- 2011 version	

SATA Filter accessories		
10934	Teflon ball tap G 1/2 inch male thread for air inlet and outlet, for SATA filters	
9878	Not a cheap throw-away. Dust, oil and condensation are filtered directly at the spray gun. 10 micron performance through sintered bronze. Condensate discharge valve. Weighs 4.4 oz.	
86892	SATA's Auto discharger is a fully automatic drain valve to eliminate condensation from your down pipes and airline drops. It is 1/2" NPT to easily connect to your drops. This requires no electricity, so can be place inside explosion proof areas.	
SATA High Volume Fittings		
13656	SATA HVLP female nipple G 1/4 female thread (use 6981 for 5-pk)	
53942	SATA HVLP male nipple G 1/4 male thread	
13599	SATA HVLP female coupler G 1/4 female thread	
13623	SATA HVLP male coupler G 1/4 male thread	
SATA Air quality control		
156299	SATA air tester, compressed air quick tester for contaminants	
7096	SATA Air Check Set-Compressed air testing device. Simply connect and allow air flow for 15 minutes or longer. Test paper traps dirt, oil and in-line contamination. Complete with test paper, tweezers, magnifying glass and exam light all in a compact carrying case.	
7666-10	Test paper, pack of 10	
7666-50	Test paper, pack of 50	
7666-100	Test paper, pack of 100	
SATA filter mounting brackets		
47290B	Mounting bracket for #47290 reg- ulator for 200 series SATA filters	

SATA® filter timer

New SATA® filter timer

Safety at the push of a button



To ensure the efficiency of a SATA filter, the unit must be regularly maintained. This helps avoid coating flaws and other quality issues that result in expensive rework.

To remind users to exchange saturated filter elements regularly, from now on all SATA filter regulator units will be supplied with a set of SATA filter timers.

Using the SATA filter timer is extremely easy: When a new filter regulator unit is installed, each filter timer must be activated by pressing the button to "start" the servicing interval of the respective filter stage. Over time, the display window will gradually turn to red, indicating the passing of time and serving as a guide to the measure of filter saturation. Whenever a window has completely changed to red, the concerned filter cartridge needs to be replaced. In line with the two different recommended replacement intervals of approx. three (activated charcoal) or six months (fine and sintered filter) respectively, there will be two filter timer versions available.

Additionally, the replacement filter cartridges will be also supplied with SATA filter timers which have to be inserted in the self-adhesive cages on the filter canisters and activated once maintenance is completed.

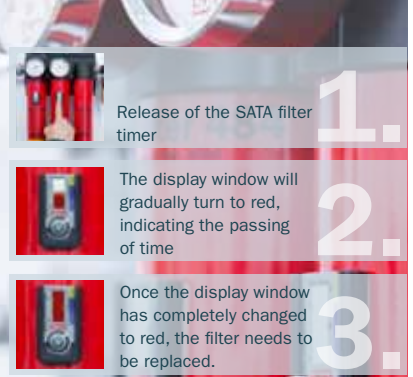

Frequent malfunctions occurring without the use of compressed air filters or with insufficiently maintained filters:

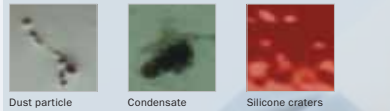

Dust particle inclusions Condensate Silicone craters

- 206151 SATA filter timer only [for SATA sinter and fine filter, 6 mo.]
- 206284 SATA filter timer starter set [for SATA sinter filter, 6 mo.]
- 206292 SATA filter timer starter set [for SATA fine filter, 6 mo.]
- 206318 SATA filter timer starter set [for activated charcoal, 3 mo.]
- 206359 SATA filter timer starter set [for SATA filter 484], set of 3

Spare Parts 200 series regulator

Pressure Regulator #47290

Order No./Desc.

2980	Diaphragm
13490	End screw cover
13912	Compression spring
14019	Valve Pin
14035	O Ring
14043	Valve seat
14068	Head piece
14076	O Ring (End Cap)
14522	O Ring 25 x 15
14530	Compression spring
16816	Bell housing
17251	Cylinder screw
17541	Counter nut M10 x 1
17590	Spindle
18077	Adjusting knob
18358	Nut, Adjusting knob
90951*	Diaphragm Repair Kit

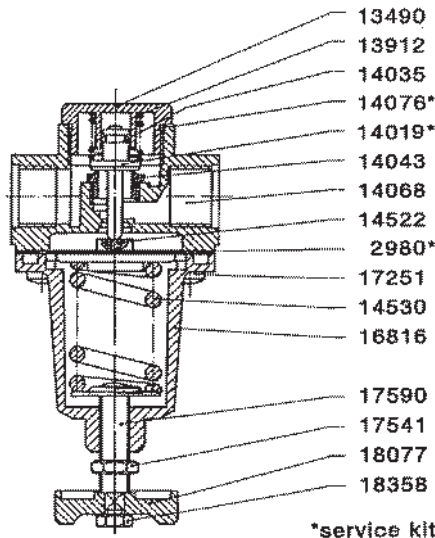

*service kit

Part No./Desc.
*90951 Diaphragm Repair Kit

Technical modifications and printing errors reserved

Filter Head Connection

Due to a design change on the SATA 400 series filters, the number of parts required for the connection between the 2nd and 3rd filter stages as well as between the 3rd stage and outlet module have been reduced from three to only two parts.

The design of the filter head has been changed to reduce the total weight of the filter unit. See illustration to the right.

SATA filter 400 series,
OLD filter head, Previous
3 piece connection



SATA filter 400 series,
NEW filter head, Spring 2011
2 piece connection



Outlet module for SATA filter 200 & 400, released 2011

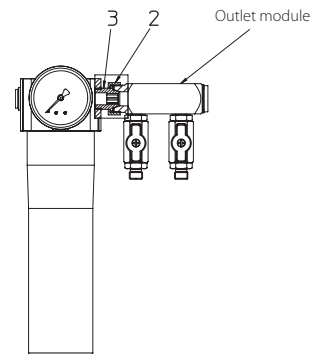
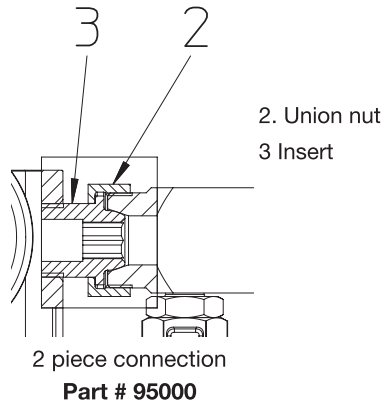
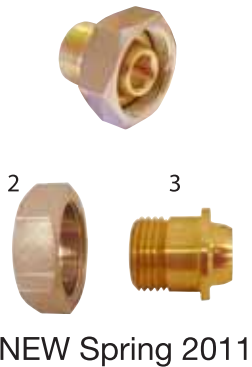

For the assembly of the new and old outlet module for the SATA filter 400 series, use Part No. 9500, new design modules already feature a male thread. The insert part is now installed on the opposite side, i.e. inside the activated charcoal filter unit, while the swivel-screw fitting (position 1 shown below), is no longer necessary. Similar changes have been made to the SATA filter 200 series as well. Please refer to the respective parts breakdown for the correct module.

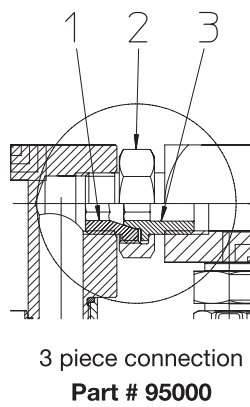
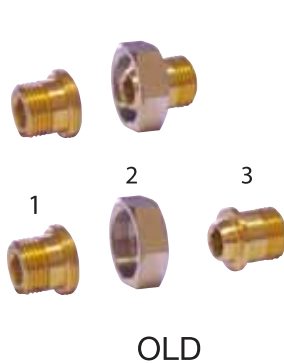

1. Swivel-screw fitting
2. Union nut
3. Insert

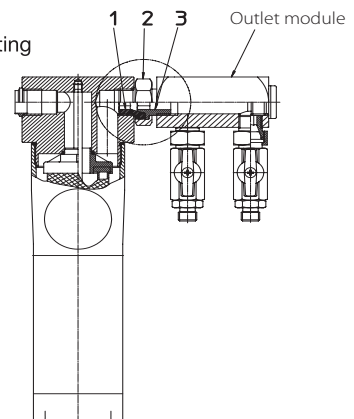

SATA filter 400 series cutaway



Technical modifications and printing errors reserved



Accessories



SATA® cleanRCS™

- Safe and rapid color change with disposable cup use, even with critical changes (e.g. black / white)
- Mounts in the spray booth or in the preparation room
- Suitable for waterborne and solvent-based paint systems
- High cleaning power and residue-free removal of all paint remainders in the paint channel, even in places hard to access
- Collecting container for used cleaning liquid avoids additional soiling of the spray booth – savings potentials due to increased booth filter life time
- No readjustment of the gun inlet pressure and no disconnecting required – automatic pressure adaptation when switching between “Spraying” and “Cleaning”
- Shelf space for prepared disposable cups during paint jobs
- Increases paint job frequency and capacity utilization of the spray booth

Only 2 cleaning steps:

1. Flushing and cleaning the paint channel and air cap (approx. 21 sec.)



2. Dry-blowing; used cleaning liquid is collected (approx. 4 sec.)

Technical Data			
	SATA RCS	SATA RCS compact	SATA RCS micro
Air consumption cleaning process		5 cfm (approx.)	
Air consumption drying process		4.5 cfm (approx.)	
Cleaning agent consumption per cleaning process		5 oz (approx.)	
Cleaning time per color change		21 sec (approx.)	
Drying time per color change		4 sec (approx.)	

SATA cleanRCS	
145581	SATA cleanRCS Recommended for mounting in the spray booth - saves valuable time Optional: Conversion kit to connect large cleaning agent containers
Technical Data	Operating pressure: max. approx. 87 - 116 psi
	Dimensions: 12" w x 28" h x 9" d
	Net weight: 22 lbs















SATA cleanRCS compact	
192518	SATA cleanRCS compact Recommended for wall mounting inside the mixing room, no need for spray air supply Optional: Conversion kit to connect large cleaning agent containers
Technical Data	Operating pressure: max. approx. 60 psi
	Dimensions: 12" w x 18.3" h x 9" d
	Net weight: 15.5 lbs



SATA cleanRCS micro	
202564	SATA cleanRCS micro Recommended for wall mounting inside the mixing room, no need for spray air supply Optional: Conversion kit to connect large cleaning agent containers
Technical Data	Operating pressure: max. approx. 60 psi
	Dimensions: 7.3" w x 18.3" h x 8" d
	Net weight: 9 lbs



Spare Parts and Accessories SATA clean RCS

Recommended connection set and Accessories		
10934	Teflon ball tap G 1/2 inch male thread for air in- and outlet	
146514	Air hose 13 mm, 500 mm long, with connection for SATA cleanRCS	
13581	SATA quick coupling 101.38 g 3/8 female thread	
147082	Grounding cable, 10 ft, 4 mm, assembled	
9886	SATA gravity gun holder for gravity cup spray guns	
146985	Repair kit SATA clean RCS	
146993	Splash guards and fixing rivets, pack of 5 each	
147017	Replacement brush, pack of 2	
147025	Replacement tubes, pack of 2	
153965	Replacement tubes, for use when using cup adapters for increased material passages. 95mm, pack of 2	
192633	Flexible tube, aluminum, 16', for suction of solvent vapors	
189472	Conversion kit external cleaning agent - suction and recirculation for SATA clean Conversion kit consists of 2x material hoses, installation guide	 <p>containers not included</p>

Technical modifications and printing errors reserved

SATA® dry jet™ 2



SATA dry jet 2

Technical Data

Air consumption: 10 cfm
Inlet pressure: 36 psi
Max inlet pressure: 174 psi



Available version

217489	<p>SATA dry jet 2</p> <p>The new SATA dry jet 2 is a practice lightweight blow gun to make quick work of drying waterborne materials. The wider and more even fan size and shape, with the new air flow cap cap can be removed for easy handling storage and maintenance. A special nozzle design multiplies air volume from ambient air using the Venturi injection principle. An air intake filter prevents contamination of the paint.</p> <ul style="list-style-type: none"> ■ 15% higher drying power than competitive products ■ Integrated air volume regulator ■ Easily exchangeable rear sieves 	
222125	SATA dry jet 2 replacement sieves, pack of 10	

NOTE - SATA dry jet, and SATA dry jet stands are no longer available, replacement parts only:

Order No./Desc.

81380	Hose only, Sata dry-jet adjustment mount
81869	Filter holder
82198	Stand w/o blow guns
82248	Filter, pack of 3
83840	Stand complete (can be disassembled)
84145	Verticle extension approx 1.2 m stainless steel
86165	Adjustable air connection, SATA dry-jet
86140	Horizontal extension w/ third blow gun
123786	Cross connection, (complete), dry jet

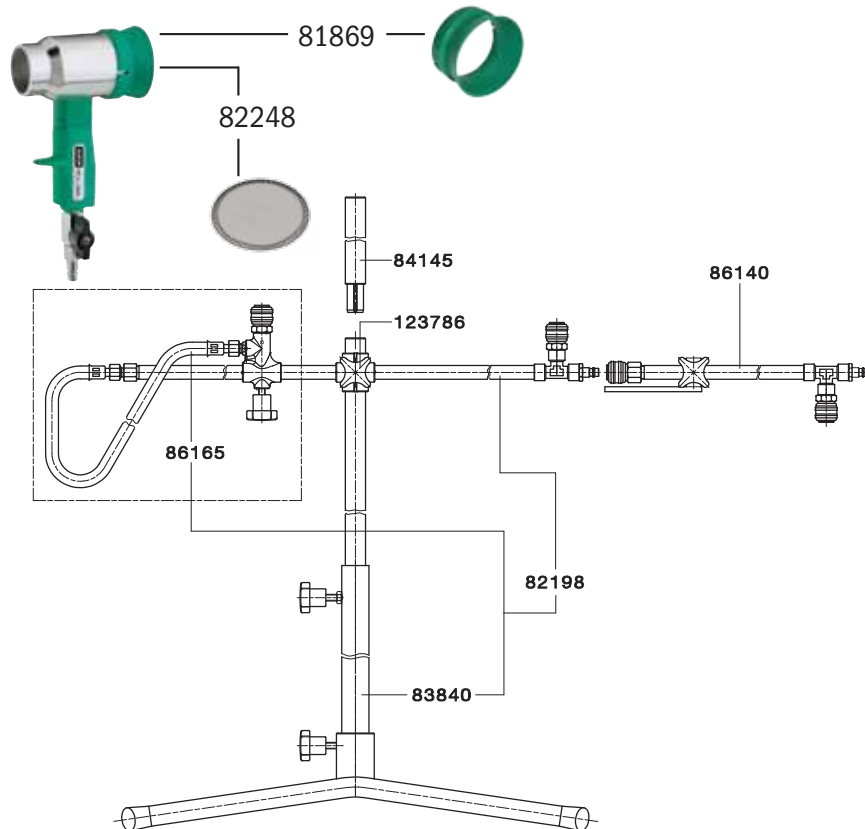

Rustproofing Equipment

Barrel pump unit for cavity preservation

14555 SATA HKU pump unit 1:3 cpl., consisting of pump 3:1, with pair of hoses 10 m, jet 1000 KK spray gun, 3 wand set, type 1 connection

HKU Technical Details	
Pump volume with nozzles:	app. 0.036 cfm
Air consumption spray gun:	7.1 cfm
Air consumption pump at 72.5 psi inlet pressure:	8.2 cfm
Air connection thread:	G 1/4 outs. thread
Total weight:	24.2 lb / 11 kg
Max. air pressure:	150 psi
Min. air pressure:	37.5 psi
Max. material pressure:	450 psi

HKU Technical Details	
Bursting pressure:	2250 psi
Free material flow:	approx. 22 l/m
Air Connection:	G 1/4 int.
Material outlet:	G 3/4 int.
Material outlet:	suction pipe G 3/4
Noise emission at 0.MPa (105 psi):	79 dB (A)2
Barrel connection with 2" thread is supplied with the pump.	



34389 SATA HKU barrel pump unit, 200 l, consisting of pump 3:1, hose pair 10 m long, jet 1000 KK spray gun, 3 wands with type 1 connection

153700 SATAjet 1000 KK 1.5 paint tube G 1/4a, special connection with coupling (8359) page 22 for details



17251WS Wand set, Type 1, set of 3
1) nylon wand - 8 x 1300mm, 2) door wand - 8 x 1100mm, 3) hook wand - venturi 750mm





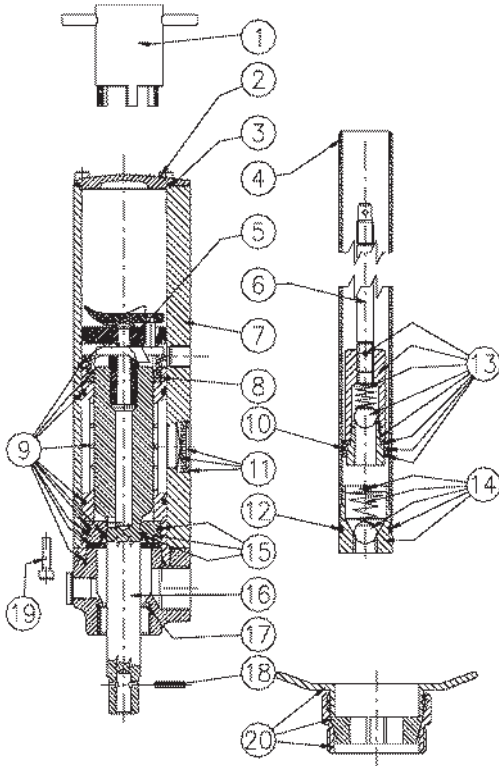











HKU pump unit



HKU Technical Details		Pos.
51961	Packing kit	8, 10, 12, 15, 17, 18
51979	Air motor repair kit	2, 3, 9, 16, 18, 19
57406	Pump tube repair kit	13, 17, 18
16063	Guiding hose	
23291	Reduction nipple	
30437	Pressure compensation containers, cpl.	
34819	SATA material-feed pump 1:3 60 l with control unit	
38679	Suction pipe for 60 litre Barrel	
39594	Sieve insert	
39727	Barrel-screwing	20
49494	SATA material feed pump 1:3 for 200 l, with control unit	
55517	Valve mechanism cpl.	5
57471	Bottom valve cpl.	14
57521	Piston rod	6, 18
70086	Suction tube for 200 litre. barrel	
80622	Pump fittings	

Rustproofing Equipment

Cavity preservation, Type 1		
9795	SATA HRS pressurized cup spray gun, Type 1, with 1.0 l cup with wands, flexible nylon, door and hook wand Special equipment for hollow cavity corrosion protection. Refillable 1 liter pressurized cup to 150 psi. May be used free spraying or connected to wands. Fine atomization from mixing cap and pressurized cup. The standard model uses Type 1 connection (small wand coupling). Complete with cup, quick coupling, steel door wand, flexible nylon wand and hook wand	
12658	SATA HRS pressurized cup spray gun with 1.0 l cup, material flow control, without wands, Type 1	
11072	SATA HRS pressurized cup spray gun with 1.0 l cup, material coupling, without material flow control, without wands, Type 1	
16071	Fixed door wand (steel), Type 1, 1.1 m long, 8 mm, with radial nozzle 360 ° radial fan	
16113	Flexible nylon wand, 1.3 m long, Type 1, 8 mm, with radial nozzle 360 ° radial fan	
11866	Venturi hook wand, 4 mm, with flexible guideway hose, Venturi spraying tube, for cavity and surface application	
11874	Flexible nylon wand 1.5 m long, 6 mm, with radial nozzle 360 ° radial fan and diagonal spray	
16139	Rigid nylon wand, Type 1, 1.1 m long, 8 mm, with radial nozzle 360 ° radial fan and spraying diagonally backwards and forwards	
24372	Flat hook nozzle for HRS	
25486	Round spray nozzle for surface application and under body protection	
8359	Material coupling for clear passage for wand systems, Type 1	
16048	Quick coupling nipple for wands 80-4133 G 1/4, Type 1	
196832	Door wand, nickel-plated steel, 6" effective length, 0.8 mm, with radial nozzle 360° for radial fan and forward spraying, 39" flexible guide hose	
Cavity preservation, Type 2		
27565	SATA HRS Rust Protection, Type 2 Economy version with 1 liter pressurized cup to 150 psi., with one nylon wand (#77941) and one hooked nylon wand (#54460)	
77941	Flexible Nylon wand, 1500mm, Type 2, w #16170 coupling	
16154	Rigid nylon wand, 1100, Type 2, 1.100 mm Ø 8 mm, with radial nozzle 360 ° radial fan and diagonal	
54460	Hook wand, 750mm, Type 2	
16170	Coupling, Type 2	
16055	Hook wand nipple, Type 2	
11213	Round spray nozzle, Type 2	
Under body protection		
12740	SATA UBE suction gun for underbody protection from disposable containers Type 1, European containers (9.5" pick-up tube)	

Spare Parts SATA® HRS™

Part No./Desc.	
3426	Safety washer 4 mm DIN 6799 stainless steel for trigger
8300	Suction pipe, drilled"
8318	Sealing ring
8359	Material coupling for clean passage for want systems
11437	End screw
11445	Compression spring
11460	Air piston
11494	Cam rod, complete with O-ring
11502	Paint needle 1.5, complete with needle sleeve
11510	Mixing cap, completely machined
11544	Compression spring for paint needle
12591	Bracket bolt for SATA paint spray guns except SATAminijet
15438	Paint needle packing
16071	Fixed door wand (steel) 1.300 mm Ø 8 mm, with radial nozzle 360 ° radial fan, Type 1
16113	Flexible nylon wand 1.300 mm Ø 8 mm, with radial nozzle 360 ° radial fan, Type 1
16139	Rigid nylon wand 1.100 mm Ø 8 mm, w/ radial nozzle 360 ° radial fan + spraying diagonally backwards + forwards, Type 1
16170	Coupling, Type 2
24372	Flat hook nozzle for HRS
25486	Round spray nozzle for surface application and underbody protection
41806	1.0 l aluminum pressure pot max pressure 10 bar / 150 psi complete with threaded ring
53082	O-ring 12 x 1.5 mm made of Perbunan
68890	Valve, cpl."
133983	Air connection piece G 1/4a
157305	Trigger

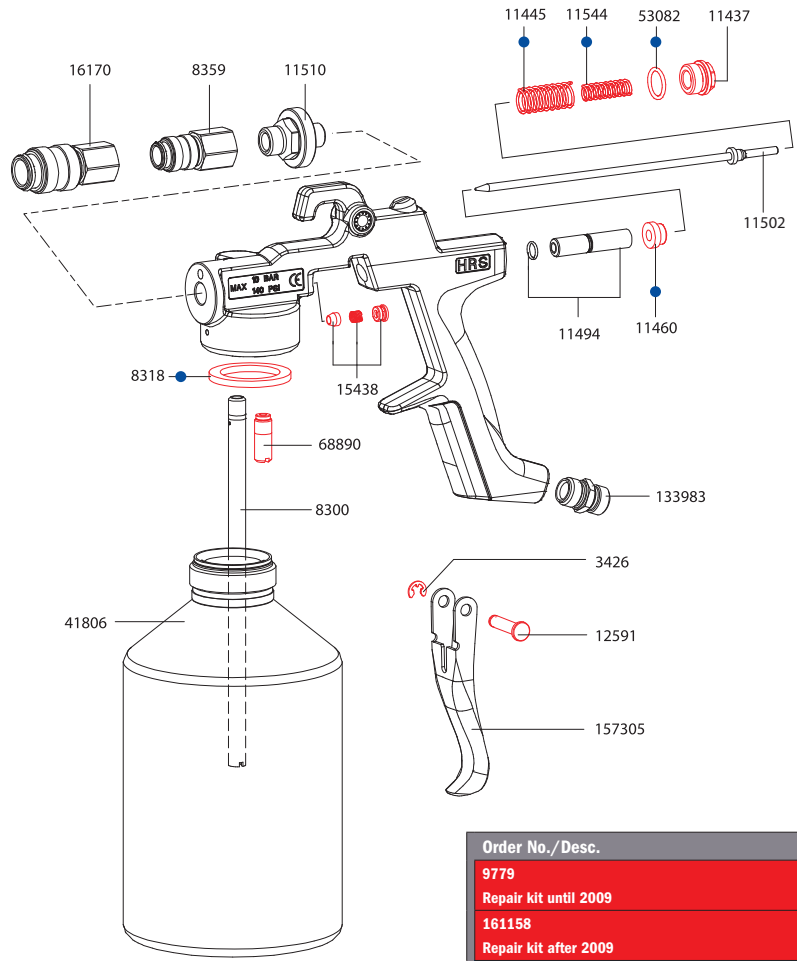



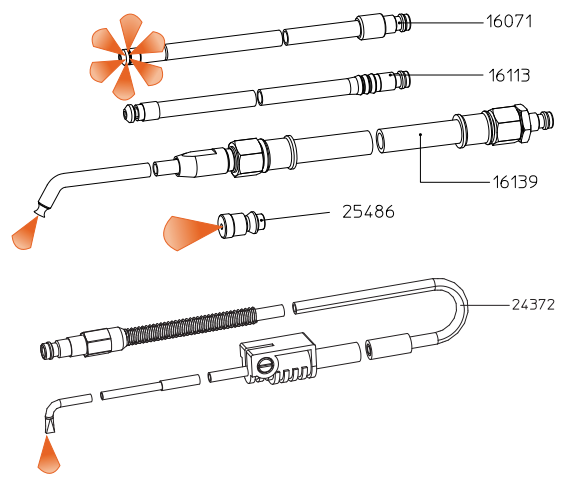







Order No./Desc.
9779
Repair kit until 2009
161158
Repair kit after 2009
50617
Air piston service set



Technical modifications and printing errors reserved

Grit Blasting Equipment / Blow Guns

Grit blasting equipment		
17335	SATA grit blasting gun super version spraying pipe w/ carbide insert	
39172	SATA sandblasting set: sand blast gun with carbide pipe, mask, gloves, blast material special order item only	
17699	SATA sandblasting hood	

Blow guns		
<p>SATA blow guns reduce costs by saving compressed air. Three types of nozzles are available in standard, noiseless and multi nozzle. The high efficiency multi nozzle design triples the air volume by means of a following-up effect. The noiseless type lowers the noise level to 79 db at 60 psi. Straight and curved nozzle extensions are available for special requirements. Air consumption of about 5 cfm at 45 psi. SATA Multi and Noiseless nozzle versions prevent pressure build-up if tip is blocked or "dead ended" Complies with OSHA requirements 1910.242b and 1910.95 when used on an air line of 150 psi or less. The standard version does not have safety by-pass and must use regulated pressure not exceeding 30 psi.</p>		
15156	SATA blow gun with standard nozzle	
26070	Standard nozzle for SATA blow gun 15156 (blow gun)	
15180	SATA blow gun with low noise metal nozzle	
77586	Special low noise nozzle for SATA blow gun 15180 (blow gun)	
15214	SATA blow gun with multi nozzle	
26047	Metal multi-nozzle M14 x 1	
133306	SATA turbo blow with quick coupling nipple	

Spare Parts SATA Grit Blasting, Blow gun, UBE undercoating

Part No./Desc.	
12831	Hexagon nut SPO ascending pipe
17699	SATA HMO head protection hood
21154	Blast pipe w/carbide insert
21451	Lid for 0.6 l PVC suction cup
38141	SATA SGE gun with carbide spray pipe
64394	Screen, pack of 5
64402	Glass visor screens, pack of 5

SATA grit blasting gun

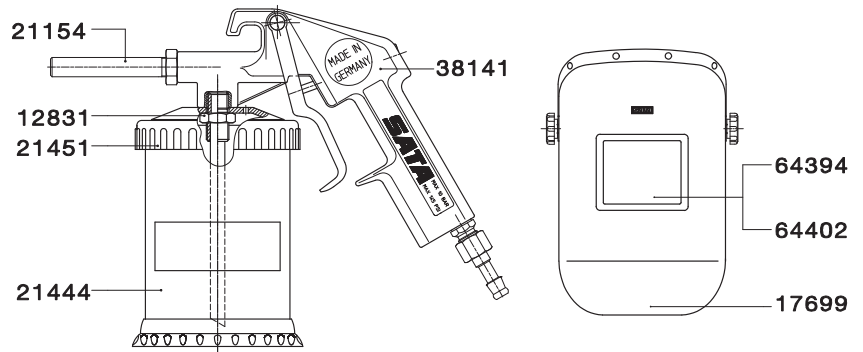

Part No./Desc.	
109	Air inlet fitting
15156	Blow gun, standard
15180	Blow gun, noiseless
15214	Blow gun, multi-nozzle
26047	Head, multi-nozzle
26070	Head, standard
55269	Gun body
77586	Head, noiseless

SATA Blow Gun

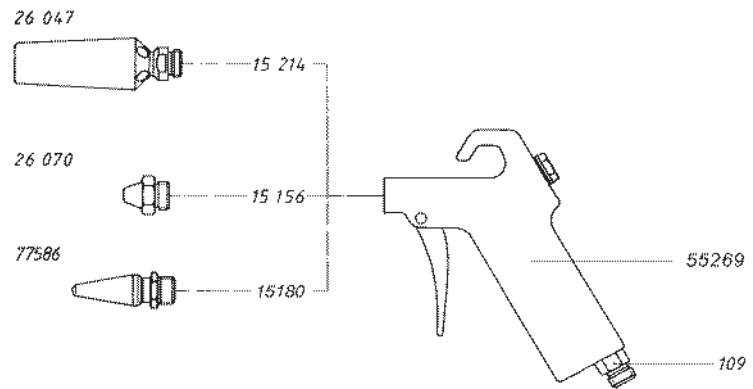

Part No./Desc.	
4788	Trigger
11098	Packing, air piston
11437	End screw
12864	Spray tube
26054	Pressure spring
53082	O ring, air piston
65979	Air piston
65987	Trigger pin
65995	Pickup tube
66001	Nozzle
66019	Circlip

SATA UBE Undercoating Gun (#12740 for one way cans-euro)

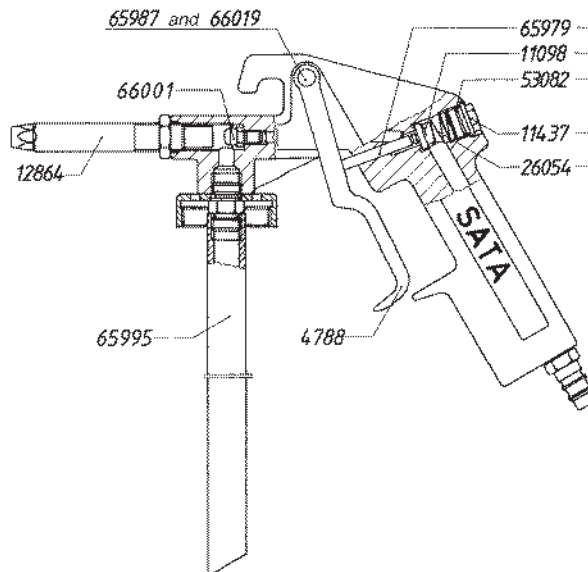



SATA® vario top spray™



SATA vario top spray

Technical Data	
	Pump ratio: 1:1
	Material Pressure: 8.0 bar / 116 psi
	Material flow volume (at 220 DH): 32 l/min
	Air inlet pressure min: 0.8 bar / 11.6 psi
	Air inlet pressure max: 8.0 bar / 116 psi
	Version and weight without add-on components
	Aluminum: 6 kg / 13 lb
	Stainless steel: 12 kg / 26 lb

Aluminum versions

81661	SATA vario top spray S, double diaphragm pump 1:1, with stand, material fine pressure regulator, without spray gun and hoses	
61507	SATA vario top spray W, double diaphragm pump 1:1, for wall mounting, with material fine pressure regulator, suction tube and 1 spray gun connection, without spray gun and hoses	
61515	SATA vario top spray F, on trolley, double diaphragm pump 1:1, with material fine pressure regulator, with suction tube	
63974	SATA vario top spray F, double diaphragm pump 1:1, on trolley w/ material fine pressure regulator, suction pipe and 2 gun connection, w/o guns	

Stainless Steel Versions - pump and material passages made of stainless steel

81406	SATA vario top spray S, for waterborne paints, w/ stand and material fine pressure regulator, suction tube and one spray gun connection	
72678	SATA vario top spray W, for waterborne paints, wall mounted version, with suction tube, w/o gun or hoses	
72694	SATA vario top spray F, for waterborne paints, on trolley, with suction tube, w/o gun or hoses	
138958	SATA vario top spray FB-WS, mobile, with fine material pressure regulator, gravity flow cup w/o suction hose, 1 spray gun connection, w/o gun or hoses	

Note this is a special order item

Technical modifications and printing errors reserved

Spare Parts SATA® vario top spray™

Order No./Desc.
17483 Trolley complete
19158 Pressure gauge 1-10 bar, 50 mm G 1/4 (0-150 psi)
19851 10-pk sieves
23986 Spray gun connection (air)
24240 Single pressure reducer w/ gauge 0-10 bars / 0-150 psi
74187 Suction globe complete, for waterborne materials
81604 Wing shaped handle
82107 Double pressure reducer, complete with gauge 0-10 bar / 0-150 psi
89169 Goose neck
149716 6.0 l gravity flow cup with lid
149732 Container stud
149740 Sealing A 33 x l 23
149948 2-pk flat sieve 20 mesh

	Standard version	Stainless steel version
1	61192 Double diaphragm pump for SATA vario top spray, coated version	88641 Double diaphragm pump for SATA vario top spray, for waterborne paints, w/ material connection M 25 x 1.5 outside thread / G 1/4 outside thread
2	24422 Material fine pressure regulator, cpl., for SATA vario top spray	25338 Material fine pressure regulator cpl. for SATA vario top spray, all parts made of V2A stainless steel
3	72918 Spray gun connection (material) cpl.	57570 Spray gun connection (material) cpl. to material fine pressure regulator for second gun
4	62232 Suction hose complete for Top-Spray	45047 Suction hose cpl., for waterborne paints, for SATA vario top spray
5	73866 Ascending pipe cpl. w/ suction cap and sieve insert for SATA vario top spray	74203 Suction tube cpl., for SATA vario top spray, for waterborne paints, on trolley, w/ gravity flow container
6	79921 Suction tube cpl. w/ suction globe and sieve insert for SATA vario top spray	80879 Suction pipe cpl., for vario top spray mobile, w/o gravity recipient, for waterborne paints
7	74245 Sieve unit, mesh size 1.0, for SATA vario top spray, for waterborne paints	
	74237 Sieve unit, mesh size 0.5, for SATA vario top spray, for waterborne paints	
8	8706 Nipple 1/2" x 1/2" BSP	82941 Double nipple G 1/2 outside thread, for sleeve ball tap, for SATA vario top spray, for waterborne materials
9	41368 Angle A 1, G 1/2 GF No. 90 galvanized version	56564 Angle 90 degree Rp 1/2 V2A, Wst.1.14436 for SATA vario top spray waterborne version
10	82909 Conversion set for gravity container SATA vario top spray	74211 Conversion kit for gravity flow container SATA vario top spray, for waterborne paints
11	37986 Add-on kit for 6 l plastic gravity container, complete with three-way ball tap and holder	37226 Add-on kit for 6 l plastic gravity container, cpl w. 3-way ball tap and holder

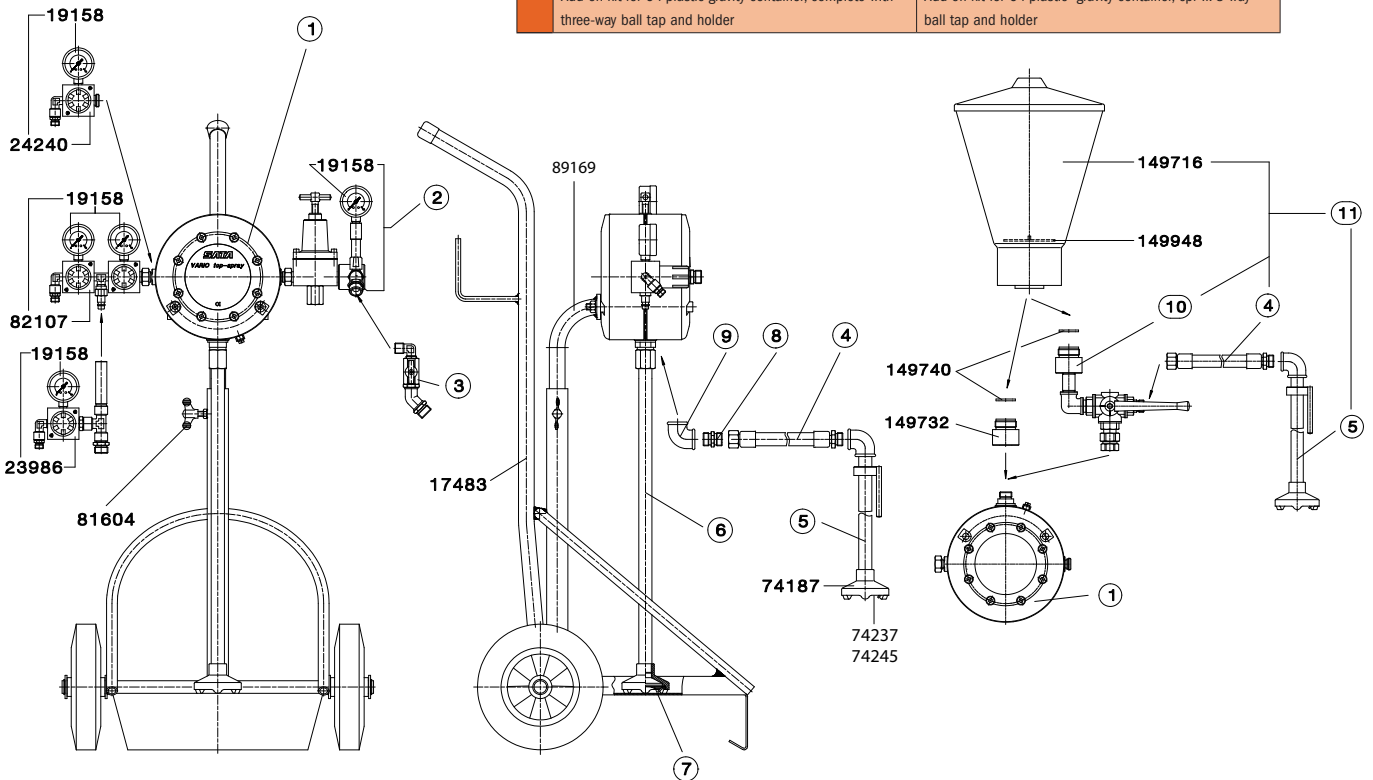

Technical modifications and printing errors reserved

Spare Parts SATA® vario top spray™ Pump

Order No./Desc.	Kit	
45195	Set of sealings, complete, for top spray double diaphragm pump	1
60012	Diaphragm repair kit for SATA vario top spray	2
60038	Control repair kit for SATA vario top spray	3
60228	Valve repair kit for SATA vario top spray	4
60301	Carrier rod repair kit for SATA vario top spray	5
60657	Carrier repair kit SATA vario top spray	6





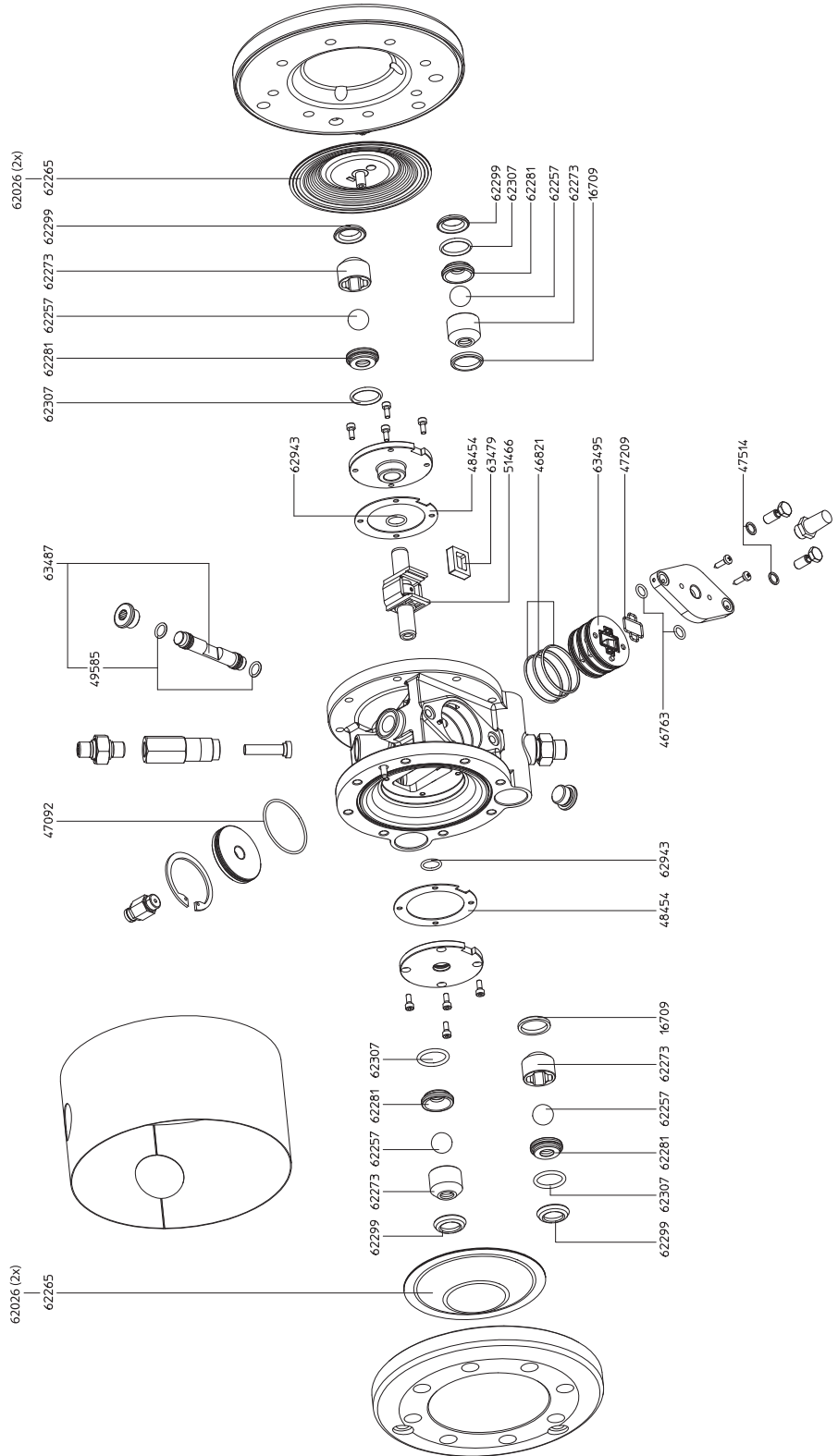

We generally recommend using aforementioned seal and repair kits as well as exchanging all essential seals and components

Single components of the seal and repair kits

Order No./Desc.	Kit	
16709	Sealing for vario top spray industrial version	4
46763	O-ring 9 x 2 B for double diaphragm pump top spray	1 3 5
46821y	O-ring 42 x 2 for double diaphragm pump top spray	1 3 5
47092	O-ring 48 x 2 for double diaphragm pump top spray	1
47209	Shape seal for double diaphragm pump top spray	1 3
47514	Sealing ring 8.2 x 11.4 x 1 for double diaphragm pump top spray	1 3 5
48454	Flat seal D 72 x T 1 for double diaphragm pump top spray	1 6
49585	O-ring 10 x 2 mm, made from Perbunan 10 shore	1
51466	Driving pin double diaphragm pump top spray	6
62257	Ball 18 mm for double diaphragm pump top spray	4
62265	Diaphragm complete D123 for SATA double diaphragm pump top spray	2
62273	Ball-bearing for double diaphragm pump top spray	4
62281	Valve seat D12 short for double diaphragm pump top spray	4
62299	Profile packing 17.2 x 28.2 x 5.4 for double diaphragm pump top spray	1 2 3 4 5 6
62307	O-ring 22 x 3 mm, FP 7010, for double diaphragm pump top spray	1 4
62943	O-ring 14 x 2 mm, Perbunan, for double diaphragm pump top spray	1 6
63479	Flat valve 24 x 19 mm, for SATA double diaphragm pump top spray	3
63487	Carrier rod D 13, 9L for SATA vario top spray, complete w/ O-ring 10.82 x 1.78	5
63495	Valve seal D 48 mm for SATA vario top spray double diaphragm pump	3



SATA® Quick Couplings

Individual components for the quick coupling system		
6981	SATA HVLP female nipple - 5-pk Quick coupling nipple G 1/4 female thread	
13656	SATA HVLP female nipple - Quick coupling nipple G 1/4 female thread	
53942	SATA HVLP male nipple - Quick coupling nipple G 1/4 male thread	
13599	SATA HVLP female QC - SATA quick coupling 100.14 G 1/4 female thread	
13623	SATA HVLP male QC - Quick coupling 100.14 G 1/4 male thread	
7237	Pack of 2 quick couplings, socket 9 mm, 2 quick coupling nipples G 1/4 female thread, 60 degrees cone.	
13508	Nipple for SATA quick coupling 104/38 G 3/8 male thread	
13557	Hose olive, 9 mm for air quick coupling	
13581	SATA quick coupling 101.38 G 3/8 female thread	
99895	SATA hose connection swivel	



Eurotech Spray Products Ltd.

Pumps, Tanks and Accessories

Carbon Monoxide Monitors

Carbon Monoxide Monitors

Ensures grade D air quality for booth and shop safety

Technical Data: X767 CO Monitor

Gas detected: CO in compressed air	Power: 110 volt AC
Detection Principle: 3 electrode electrochemical	Operating Temp: 0° - 48 °C
Calibration: preset to 5 ppm	Dimensions: 4" x 6" x 3.5"
Continuous lifetime operation	Weight: 4.2 lbs
Warranty: 2 years	Powered coated metal housing

Carbon Monoxide Monitor Versions

X767-PLUS	<p>110 volt AC Carbon Monoxide Monitor.</p> <p>Calibrated to 5 ppm with alarm and digital display/readout in 1 ppm increments with response time of 10 seconds to 95%. Audible and visual alarms for high CO or sensor failure. RFI filtered from interference of cell phones, two-way radios, etc. Proven reliable performance electrochemical sensor. Calibration recommended every 6 months & Remote alarm options available</p>	
-----------	---	---

Carbon Monoxide Monitor Accessories

XA176	Standard 85 db remote alarm for Carbon Monoxide Monitor	
XA176A	Extra loud 100 db remote alarm for Carbon Monoxide Monitor	
XA176B	Extra loud 120 db air horn w/ regulator for Carbon Monoxide Monitor	
	Call for availability (this alarm only)	

X144 "ICOM" Individual Carbon Monoxide Monitor



X144	<p>"ICOM", Individual CO Monitor</p> <ul style="list-style-type: none"> ■ Mounts inside the respirator hood ■ Battery powered stand alone unit ■ Weighs less than 1 ounce <p>The battery powered X144 ICOM is a high performance, simple and effective tool for monitoring Carbon Monoxide. A control chip is factory set and programmed to alarm (76db) when the CO level in compressed air exceeds the OSHA standard of 5 ppm. Because it is so tiny, it mounts on the inside of the SATA vision 2000 supplied air respirator hood with a Velcro strip. The X144 ICOM is designed specifically to be affordable and easy to use in any shop. The X144 is small - only 2.4 x 1.4 x 0.6 inches and it weighs less than an ounce. Monitor accuracy is +/-10% of reading at standard conditions between 0° - 50 °C. Normal operating life is one year and that can be extended by replacement of the battery and sensor.</p> <p>The instrument may also be returned annually for battery and sensor change at customer expense.</p>	
CR2450N	Battery replacement	

Eurotech Hoses

Air Hoses - for use with supplied air respirators and filter units

55640	52 in / 1.3 m paint whip hose - to connect SATA spray gun and belt unit	
3366-15	15 ft / 4.6 m Premoflex non-gassing hose - 3/8 in ID w/ 1/4 in NPT male fittings	
3366-25	25 ft / 7.6 m Premoflex non-gassing hose - 3/8 in ID w/ 1/4 in NPT male fittings	
3366-35	35 ft / 10.7 m Premoflex non-gassing hose - 3/8 in ID w/ 1/4 in NPT male fittings	
6633-50	50 ft / 15.3 m Premoflex non-gassing hose - 3/8 in ID w/ 1/4 in NPT male fittings	
6633-60	60 ft / 18.3 m Premoflex non-gassing hose - 3/8 in ID w/ 1/4 in NPT male fittings	
6633-75	75 ft / 22.8 m Premoflex non-gassing hose - 3/8 in ID w/ 1/4 in NPT male fittings	
6633-100	100 ft / 30.5 m Premoflex non-gassing hose - 3/8 in ID w/ 1/4 in NPT male fittings	



High Quality Combination Hoses for 10 - 40 l Pressure Tanks and 1:1 Pumps

675206	6 ft / 1.8 m dual hose - 1/4 x 1/4 in air fittings + 3/8 x 1/2 in material fittings (all female fittings)	
675215	15 ft / 4.6 m dual hose - 1/4 x 1/4 in air fittings + 3/8 x 1/2 in material fittings (all female fittings)	
675225	25 ft / 7.6 m dual hose - 1/4 x 1/4 in air fittings + 3/8 x 1/2 in material fittings (all female fittings)	
675250	50 ft / 15.3 m dual hose - 1/4 x 1/4 air hose fittings + 3/8 x 1/2 material fittings (all female fittings)	
19869	4.9 ft / 1.5 m dual hose - 9 x 9 mm ID female fittings - for use on 2.0 l pressure pot	
120501	6.5 ft / 2 m dual hose - 9 x 9 mm ID female fittings - for use on 2.0 l pressure pot	
6056	19.6 ft / 6 m dual hose - 1/4 x 1/4 in female air hose fittings + 3/8 x 1/2 in female material hose fittings	
6064	32.8 ft / 10 m dual hose - 1/4 x 1/4 air hose fittings + 3/8 x 1/2 material hose fittings	
6080	49.2 ft / 15 m dual hose - 1/4 x 1/4 in female air hose fittings + 3/8 x 1/2 in female material hose fittings	

High Quality Combination Hoses for High Efficiency Pumps

640225	25 ft / 7.6 m dual hose - 1/4 in ID female air hose fittings + 3/16 in ID female material hose fittings	
640250	50 ft / 15.3 m dual hose - 1/4 in ID female air hose fittings + 3/16 in ID female material hose fittings	

Air and Combination Hoses for SATAminijet 3000 B, SATAgraph 1, 2, 3 & 4, SATAjet 20 B

32987	9.8 ft / 3 m x 4 mm PVC compressed air hose for SATAgraph and SATAjet 20 B	
S040	6 ft braided hose, 1/8" X 1/4"	
S041	10 foot braided air hose 1/8" X 1/4",	
S042	6 ft braided hose w/moisture trap	
S045	8 ft braided hose w/quick disconnect (shown)	
54353	6.5 ft / 2 m clear PVC compressed air hose for SATAminijet and SATA 20 B. 6 ID x 1/4 female fittings	

Hosemate

10102 (2x)	Designed to guide twisted hoses and electrical cords effortlessly around wheels, the Hosemate slips quickly and easily on any standard size tire. When painting or washing a vehicle the hose glides easily over the surface of the Hosemate. This means the painter can maneuver quickly and freely while applying costly time-sensitive coatings. It also reduces wear and tear on expensive hoses and saves prep and work time.	
---------------	--	---

Paint Suits

Eurotech Paint Suits

White Eurotech paint suits are machine washable with zip front enclosure and Bold SATA logo across the back.

The **Pro-Series** paint suit is expertly designed for fit and movement, with sewn in Carbon Fibre Thread to dissipate electrostatic charges which cannot wash out. Made with the finest quality fabric and specially treated to keep it lint free. Comes with the special Mike Elwood design SATA Twisted Fire on the back and SATA spray gun logo on the front. The suit has a covered heavy duty zipper, interior utility pocket, adjustable sleeve and leg velcro closures, wide leg, adjustable elastic waste band for fit and comfort, fully breathable back fabric, 2 utility back pockets, underarm zipper opening for ventilation when needed, bi-swing shoulders for easier movements. Machine washable.



White Eurotech Paint Suit with SATA Logo

510052	Small paint suit
510054	Medium paint suit
510056	Large paint suit
510058	X-Large paint suit
510060	XX-Large paint suit
510062	XXX-Large paint suit
510064	XXXX-Large paint suit



Pro-Series Paint Suit with Twisted Fire Graphic

510052PS	Small pro-series paint suit
510054PS	Medium pro-series paint suit
510056PS	Large pro-series paint suit
510058PS	X-Large pro-series paint suit
510060PS	XX-Large pro-series paint suit
510062PS	XXX-Large pro-series paint suit



Sizing Chart for Paint Suits

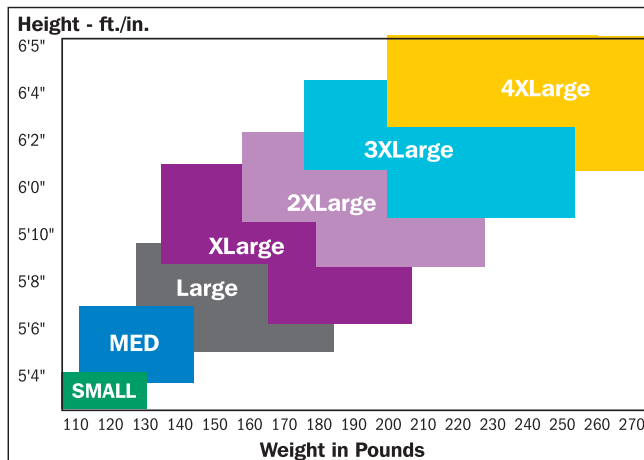

Note: Size of suit varies with under-clothing, however Pro-Series paint suits are designed a bit larger to fit over normal clothes, please order accordingly.

SATA Race Painting Coveralls

Professional SATA painting coveralls in race car suit design. Grey on grey with red piping, covered zipper and elastic wrist and ankle fittings for optimal functionality.

The Polyester (98%) - Carbon (2%) blend is machine washable, and allows for maximum comfort and easy mobility while breathing to keep the painter at a comfortable temperature.



One way ventilated technology helps ensure outside environmental toxins won't seep through the material.

187267	Small SATA painting coverall
184275	Medium SATA painting coverall
184283	Large SATA painting coverall
184291	X-Large SATA painting coverall
184309	XX-Large SATA painting coverall



Welding Blankets & Gear

Welding Blankets

31654	48" x 60" (4' x 5') Velvet Shield welding blanket, made from carbon fibre fabric. Continuous Operating temp: 980 °C. Previous part # EUA1654	
31646	48" x 72" (4' x 6') Velvet Shield welding blanket, made from carbon fibre fabric. Continuous Operating temp: 980 °C. Previous part # EUA1664	
31660	60" x 80" (5' x 6.8') Velvet Shield welding blanket, made from carbon fibre fabric. Continuous Operating temp: 980 °C. Previous part # EUA1660	
37246NG	48" x 72" (4' x 6') Toughguard welding blanket, made from heat cleaned fibre glass. Continuous Operating temp: 540 °C. Previous part # EUA7246	
37266NG	72" x 72" (6' x 6') Toughguard welding blanket, made from heat cleaned fibre glass. Continuous Operating temp: 540 °C. Previous part # EUA7266	
37286NG	72" x 96" (6' x 8') Toughguard welding blanket, made from heat cleaned fibre glass. Continuous Operating temp: 540 °C. Previous part # EUA7286	
Please inquire for custom sizes		

Pro-Series™ FR Jacket

9 oz. flame retardant cotton fabric maintains its flame resistant properties for as many as 50 home washings or 25 commercial washings without taking away from its natural lightweight comfortable characteristics. It is a cooler, lighter, economical solution for light exposure to sparks and spatter.

1160 S	Weldlite Pro-Series Welding Jacket - Small	
1160 M	Weldlite Pro-Series Welding Jacket - Medium	
1160 L	Weldlite Pro-Series Welding Jacket - Large	
1160 XL	Weldlite Pro-Series Welding Jacket - X-Large	
1160 XXL	Weldlite Pro-Series Welding Jacket - 2X Large	
1160 XXXL	Weldlite Pro-Series Welding Jacket - 3X Large	

Pro-Series™ TIG Welding Glove

Premium grain kidskin leather (including cuff) 4" grain kidskin cuff, Straight Thumb, Kevlar R sevn

P760 S	Pro-Series Welding Glove - Small	
P760 M	Pro-Series Welding Glove - Medium	
P760 L	Pro-Series Welding Glove - Large	
P760 XL	Pro-Series Welding Glove - X-Large	
P760 XXL	Pro-Series Welding Glove - 2X Large	

Grain Goatskin TIG Welding Glove

Grain goatskin leather, Unlined with Sensi-TIG™ seamless index finger & 4" Cuff

0227 S	Grain Goatskin Welding Glove - Small	
0227 M	Grain Goatskin Welding Glove - Medium	
0227 L	Grain Goatskin Welding Glove - Large	
0227 XL	Grain Goatskin Welding Glove - X-Large	

General Accessories

Autowriters

EU0050	12-pk yellow automotive markers
EU0051	12-pk blue automotive markers
EU0052	12-pk green automotive markers
EU0053	12-pk orange automotive markers
EU0054	12-pk pink automotive markers
EU0055	12-pk red automotive markers
EU0056	12-pk white automotive markers
EU1212	12-pk assorted colours automotive markers



Big Glass Automotive Markers

EU22150	Big glass - yellow 6-pk marker
EU22151	Big glass - blue 6-pk marker
EU22152	Big glass - green 6-pk marker
EU22153	Big glass - orange 6-pk marker
EU22154	Big glass - pink 6-pk marker
EU22155	Big glass - red 6-pk marker
EU22156	Big glass - white 6-pk marker



Film Thickness Gauge

DFT-COMBO	Film thickness gauge reads ferrous and non-ferrous materials with fast repeatable measurements. No calibration required. Complete with leather pouch and hard cover.
-----------	--



Eurotech Fast Mask

EU18	18 x 20 cm, high temperature masking tape. Medium strength, natural rubber adhesive Available in single unit or cases of 75.
------	--



Eurospray Pump Bottle

EUV11	1.0 l Eurospray pump bottle with VITON seals - suitable for waterborne cleaning agents only
EUE11	1.0 l Eurospray pump bottle with EPDM seals - suitable for waterborne cleaning agents only



Padded Kneeler

KNE0002	<p>This handy padded Kneeler will work great for any job requiring you to kneel down on hard surfaces. Light weight, durable, comfortable, easy to clean with soap and water.</p> <p>Does not break down in thinner or acetone when wiping off paint overspray.</p> <p>Extremely comfortable when working on.....</p> <ul style="list-style-type: none"> • Grated paint booth or concrete floors for masking in and painting vehicles • Collision repair or mechanical jobs low on a vehicle • Washing or detailing vehicles • Gardening projects • Carpentry projects including carpet laying, installing wooden floors, or in stalling trim • Plumbing projects when working under cabinets
---------	---



General Accessories

Gun Cabinets

95 Large double door lockable gun cabinet made of 20 gauge steel
 Complete with two shelves, locker, hangers for 7 gravity fed spray guns
 Measurements: 46 in w x 35 in h x 12 in d / 116 cm x 89 cm x 30.5 cm
Special order item, please allow several weeks for delivery



96 Small single lockable gun cabinet
 Material: 20 gauge steel
 Storage: 1 shelf, and hangers for 7 gravity fed spray guns
 Measurements: 25 in w x 35 in h x 12 in d / 63 cm x 89 cm x 30.5 cm
Special order item, please allow several weeks for delivery



Aluminum Storage/Carrying Case

1263EMP Aluminum case with foam insert.
 Compact aluminum case for spray equipment Compartments for up to 5 SATA spray guns with SATA adam 2 docks attached, and gravity paint cups. Other compartments for SATA accessories. Overall size measures 18 W x 13¹/₂ D x 6 H. The aluminum case is sold EMPTY.



DanAm Air Vac

DAA1001K DanAm Air Vac removes foreign objects from wet paint/clearcoat. Eliminate dirt nibs, bugs, lint, hair or other airborne debris right after it lands.
 The DAA Vac simply connects to your existing airline in the booth. Open the valve and the air creates a vacuum through the tool. Use the fine clear disposable tips to remove the debris from the wet paint/clearcoat, and use the disposable dropper to put a drop of paint/clearcoat back into the void. The paint/clearcoat will melt into the wet surface and you may have very light sanding and polish for perfection, if any at all.



Kit includes
 1 DanAm Air Vac w/ball valve
 1 4' suction hose w/tip
 12 Tips, clear vacuum
 1 Dropper



Parts for DanAm Air Vac

Position	Part No.	Description
1	DAA1001K	DanAm Air Vac complete
2	DAA1002T	Clear tips, disposable, 20 pk
3	DAA1003H	Black suction hose, 4'
4	DAA1004D	Dropper, disposable, 5 pk
5	DAA1005V	Ball valve
6	DAA1006BT	Tip, black hose, ea

Technical modifications and printing errors reserved

Piranha Pump Spare Parts

Only replacement parts available

Order No./Desc./Qty		
685700	Pump Only	1
685701	Bolt M6 - 1.25 x 16	4
685702	Top plate - air motor	1
685703	Bottom plate - air motor	1
685704	Gasket air motor top	1
685705	Gasket air motor bottom	1
685706	Air motor plunger	1
685707	Bolt M6 - 1.25 x 32	2
685708	Gasket air motor to pump	1
685709	Air motor directional valve body	1
685710	Piston w/O-rings - air motor	1
685711	Pump body	1
685712	Silencer	1
685713	Sealing ring, white drive shaft	2
685714	Sq. cut O-ring, black, drive shaft	2
685715	Drive shaft	1
685716	O-Ring	2
685717	O-Ring	2
685718	Bushing	2
685719	Snap Ring	2
685720	Backer plate	2
685721	O-Ring	4
685722	Diaphragm	2
685723	Backer plate	2
685724	SS nut M8 - 1.25	2
685725	SS Cover Plate	2
685726	SS Material outlet manifold	1
685727	SS Material inlet manifold	1
685728	Bolt, M8 - 1.25 x 45	8
685729	Washer, outlet manifold	4
685730	SS plug 3/8	6
685731	Nylon O-ring	8
685733	Ball guide	4
685734	SS check ball	4
685735	Check ball retaining seat	4
685736	Bolt w/nut M8 - 1.25 x 25	12
Pickup Pieces		
685740	SS Adapter 3/8 x 1/2	
685741	SS Coupling 1/2	
685742	SS Pipe 1/2 x 24	
685743	SS Rock catcher 1/2	
685745	SS Pickup. assembly	
	Includes: 685741, 685742, 685743)	
685746	Pump mounting foot	
685747	Mounting plate	
685748	Mounting plate bolt set	

Repair Kits - Piranha Pump

Part no./Descr.	
685750	Air Motor Repair Kit Includes: 685704 (1), 685705 (1), 685708 (1), 685710 (1)
685755	Drive Shaft Seal Kit Includes: 685713 (2), 685714 (2), 685716 (2), 685717 (2), 685721 (4)
685760	Drive Shaft Repair Kit includes: Seal Kit #685755 & Drive Shaft #685715
685765	Ball Check Valve Repair Kit Includes: 685731 (8), 685733 (4), 685734 (4), 685735 (4)

685770 Piranha 338 Pump

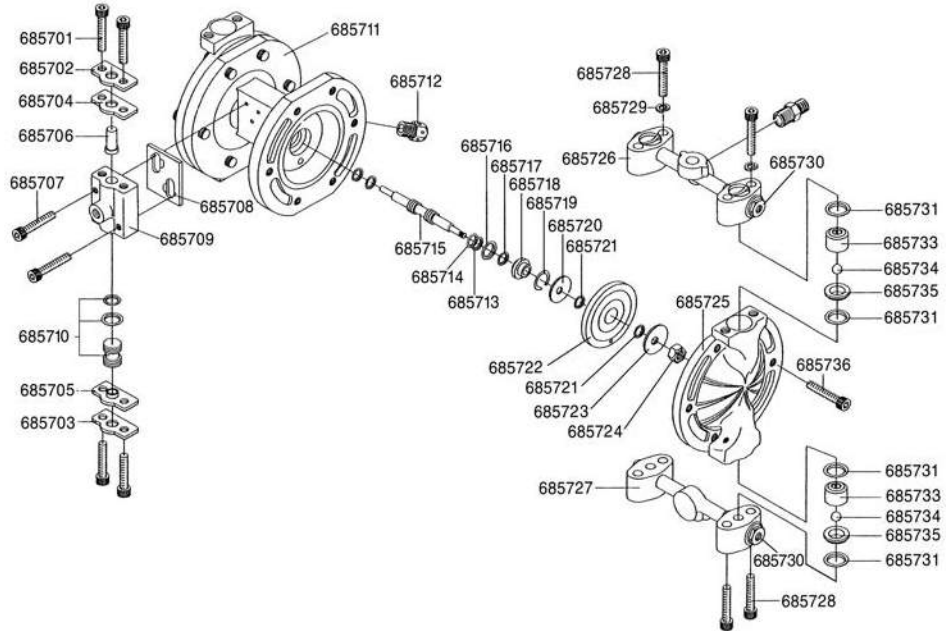

Order No./Desc.

675620	Regulator Body
677002	1/4" Hex Nipple
677039	1/8" Plug
677063	1/4" Street Elbow
677083	1/4" Tee Fitting
677504	1-1/2" Gauge 100 PSI

685770 Dual Regulator

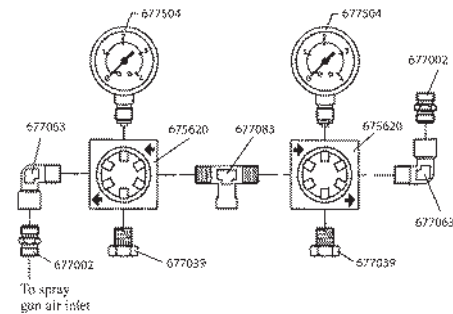

Order No./Desc.

685871	Cap Fluid Regulator
685872	Housing Base Fluid Regulator
685873	Guide Plate
685874	Spring
685875	Diaphragm Assembly
685876	Allen Bolt
685877	Fluid Inlet Check Ball & Seat Assm.
685878	1/4 90° Street Elbow SS
685879	1/4 BSP x 1/4 NPT Adapter SS
685880	1/4 NPT Ball Valve SS
685881	1/4 NPT x 3/8 BSP Adapter SS
685882	Fluid Valve Assembly SS
685883	Gauge - Fluid Regulator
685884	Tube - Fluid Regulator
685885	90° Adapter - Fluid Regulator
685886	Adjustment T - Handle
685887	Nut - Regulator Adjustment
685888	Nut - Fluid Inlet
685889	Fitting - Fluid Inlet
685890	Needle rod

685870 Fluid Regulator

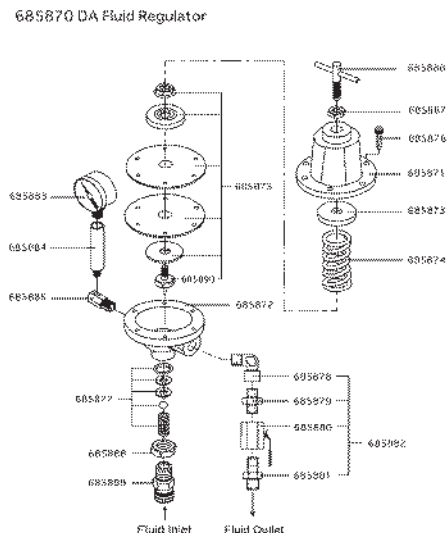

2.0 Litre Pressure Pot

2.0 Quart pressure pots

670200

2.0 l pressure pot w/ 3 port deck single regulator with pressure gauge and safety valve, complete with belt hook for ease of mobility



Order No./Desc.

L080210	1
Pressure pot hooked handle	
L080211	2
Handle lock nut	
L080212	3
Outlet tee	
L080213	4
Connector - 2 pieces	
L080214	5
Air regulators complete (number 6-24)	
L080635	6
Safety air valve, mini	
L080219	10
Regulator body	
L080220	11
Connector, pack of 3	
L080221	12
Gauge 0-60 psi, btm 1/8 chrome	
L080222	14
Spring	
L080223	15
Valve	
L080224	16
Valve housing	
L080225	17
Diaphragm complete	
L080231	20
Spring	

Order No./Desc.

L080232	21
Brass spring retainer	
L080233	22
Red regulator housing cover	
L080234	23
Locking nut, thumb wheel	
L080235	24
Regulator knob	
L080236	25
Pressure release screw, previous part #670212	
L080238	27
Lid	
L080239	28
Gasket new, 2 quart, previous part #670210	
L080240	29
Air check valve complete, previous part #670216	
L080242	30
Check valve, nylon ball	
L080892	
Check valve steel ball - optional (see item #30)	
L080243	31
Check valve, spring, previous part #672006	
L080244	32
Check valve, seal	
L080246	34
Fluid tube	
L080247	35
2 quart cup, with fine threading	

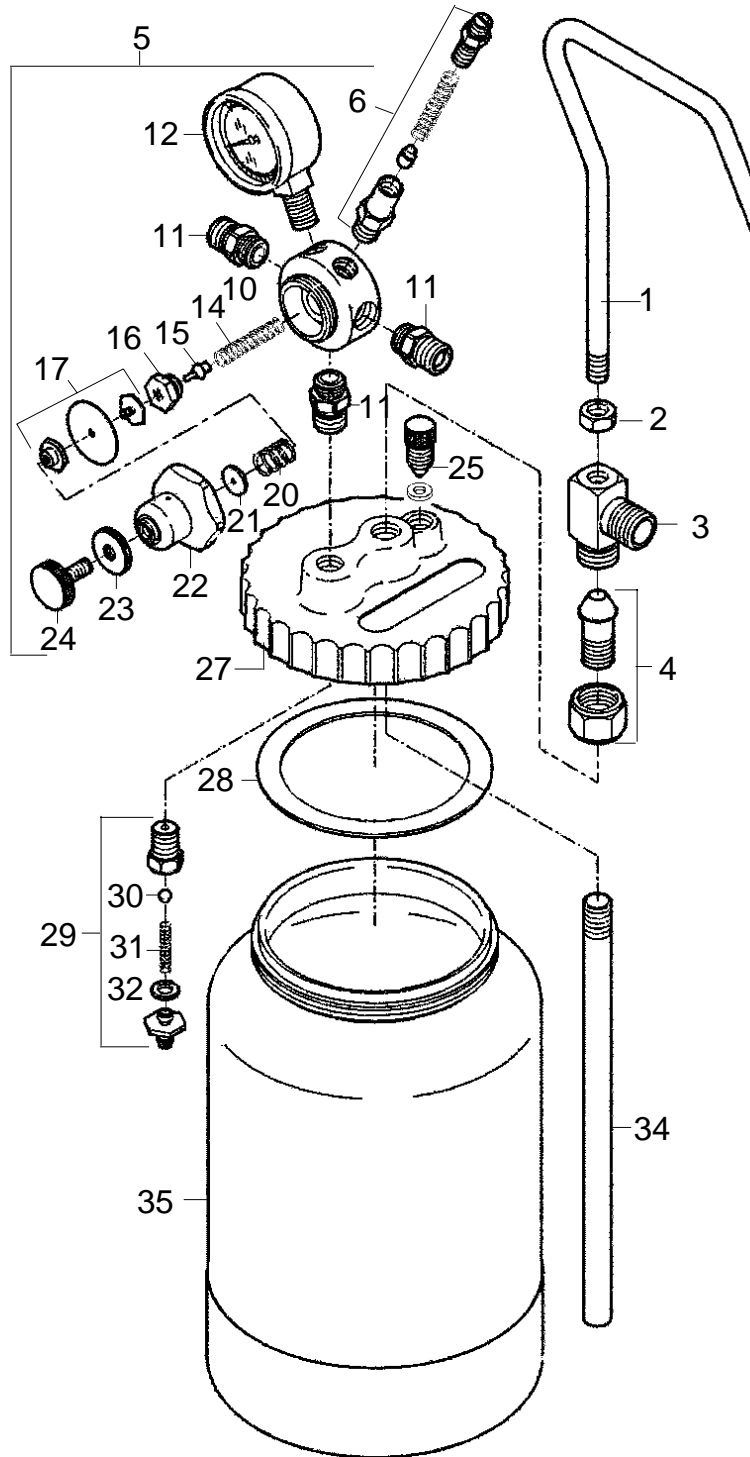

Technical modifications and printing errors reserved

10 - 20 Liter Pressure Tanks

10 - 20 Liter Pressure Tank

Quality line of pressure tanks from 10 to 40 liter. These cost-effective tanks are supplied complete with a quality regulator, over-pressure valve, back-check valve and fluid shut-off valve. Models include 10 liter pressure tanks with single or double pressure regulator either plain, with manual stirrer or with pneumatic stirrer. Other 20 and 40 liter variations are also offered with single or double pressure regulator. Tanks are mounted on wheels for ease of handling and mobility.

10 Liter pressure tank

671100	10 l pressure pot w/ single regulator, over-pressure valve, back check valve, fluid shut off valve w/o stirrer	
681100	10 l pressure pot w/ double regulator, over-pressure valve, back check valve, fluid shut off valve w/o stirrer	
671200	10 l pressure pot w/ single regulator, over-pressure valve, back check valve, fluid shut off valve and manual agitator	
681200	10 l pressure pot w/ double regulator, over-pressure valve, back check valve, fluid shut off valve and manual agitator	
671300	10 l pressure pot w/ single regulator, over-pressure valve, back check valve, fluid shut off valve and pneumatic agitator	
681300	10 l pressure pot w/ double regulator, over-pressure valve, back check valve, fluid shut off valve and pneumatic agitator	



20 Liter pressure tank

682100	20L pressure pot w/ double regulator, over-pressure valve, back check valve, fluid shut off valve w/o stirrer	
672200	20L pressure pot w/ single regulator, over-pressure valve, back check valve, fluid shut off valve and manual agitator	
682200	20L pressure pot w/ double regulator, over-pressure valve, back check valve, fluid shut off valve and manual agitator	
672300	20L pressure pot w/ single regulator, over-pressure valve, back check valve, fluid shut off valve and pneumatic agitator	
682300	20L pressure pot w/ double regulator, over-pressure valve, back check valve, fluid shut off valve and pneumatic agitator	

40 Liter pressure tank

674300	40L pressure pot w/ single regulator, over-pressure valve, back check valve, fluid shut off valve and pneumatic agitator	
684300	40L pressure pot w/ double regulator, over-pressure valve, back check valve, fluid shut off valve and pneumatic agitator	

Accessories for pressure tanks

671060-10	10L Pressure tank disposable liner, 10 pack	
671060	10L Pressure tank disposable liner, 60 pack	
672012	20L Pressure tank disposable liner, 12 pack	
672024	20L Pressure tank disposable liner, 24 pack	

See page 147 for hoses

Eurotech Pressure Pots are special order items, please allow several weeks for delivery.

Spare Parts 10 Liter Pressure Tank

Part No./Descr.	
671001	Pressure tank, 10 L
671002HD	Wheel assembly
671003	Swing bolt assembly
671004	Fluid tube
671005	Fluid sieve kit
671006	Tank lid
671007	Lid gasket
671008	Handle
671009	Pressure relief valve
671010	Secondary over pressure release valve
671011	Fluid Valve Assembly, single
671034	Swivel Connector, Male/Female
671045C	10L deck, w/o regulator, complete
671060	Disposable liner, 10L, Pk of 60
671060-10	Disposable liner, 10L, Pk of 10
671071	Fluid outlet
671072	Fluid sieve housing

671045C 10 Liter deck, W/O regulator, (includes everything shown below)

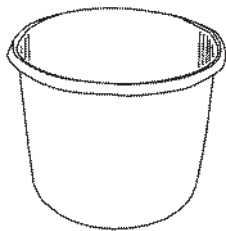
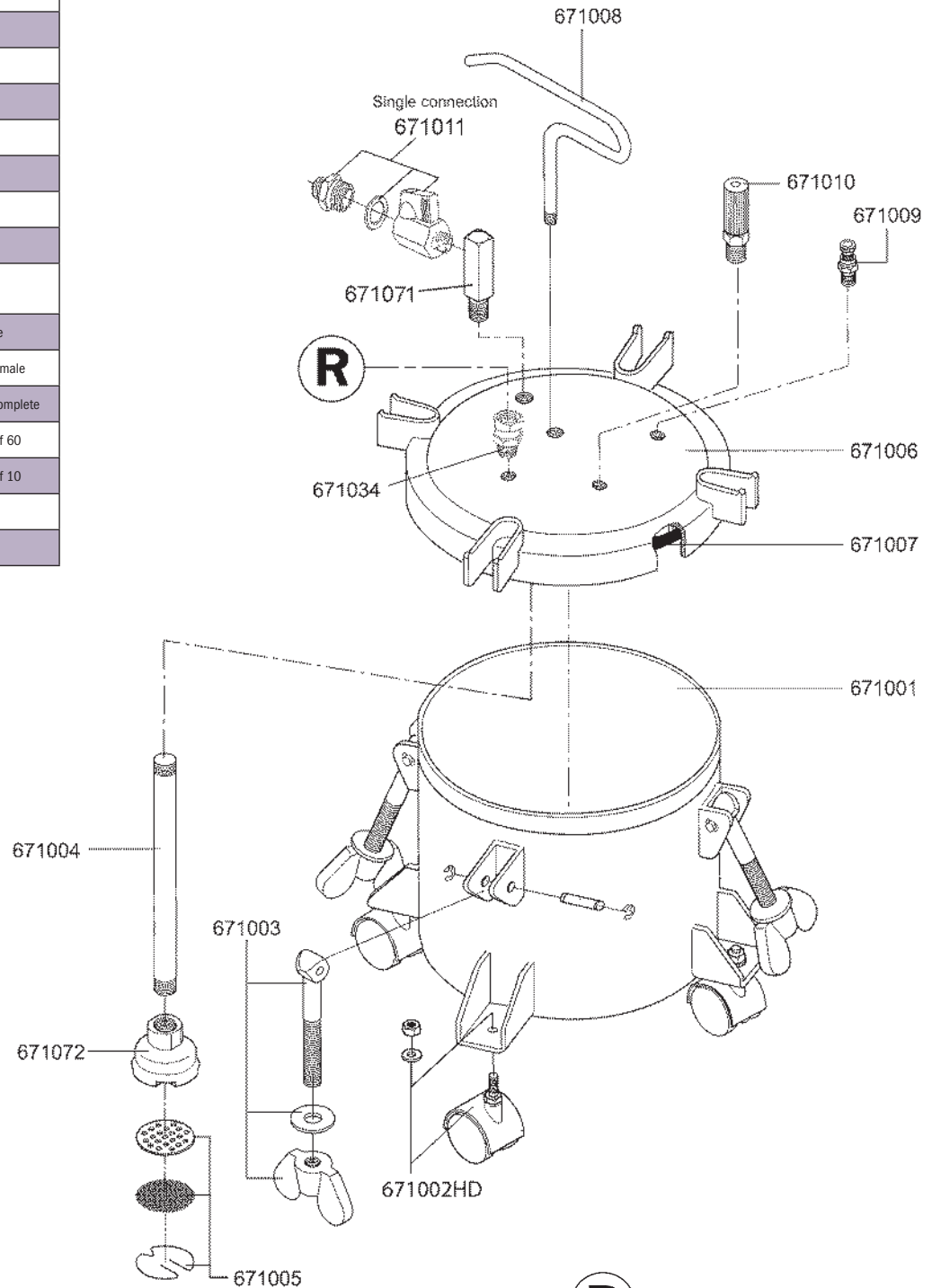

10L disposable liners

671010-10 Pk of 10

671060 Pk of 60

(R) = Regulator
See page 158, 158

Spare Parts 10 Liter Pressure Tank Lid

Part No./Descr.

671007	Lid gasket
671009	Pressure relief valve
671010	Secondary over pressure release valve
671011	Fluid valve assembly
671019	Manual agitator shaft
671020	Manual crank base
671021	Manual crank handle assembly
671022	Parts guard assembly
671023	Pneumatic agitator shaft
671024	Motor base assembly
671025	Connecting bushing assembly
671026	Air motor
671033	Agitator air line assembly
671034	Swivel connector, male/female
671035	Tank lid
671071	Fluid outlet
671045	10L deck w/crank w/o reg, complete lid
671045A	10L deck w/air agitator, w/o reg, complete lid
671073	Manual agitator propeller w/bolt
671074	Pneumatic agitator propeller w/bolt
671075	Agitator base nut
671076	Manual agitator shaft lock collar w/bolt
671077	Agitator base gaskets
671078	Pneumatic agitator shaft lock collar assembly
671079	O-ring, Manual agitator base, pack of 2
671080	O-ring, Pneumatic agitator base, pack of 2



= Regulator

See page 158, 159

Manual Crank Agitator Version

671045 10 Liter deck, W/crank, W/O regulator, (includes everything shown below)

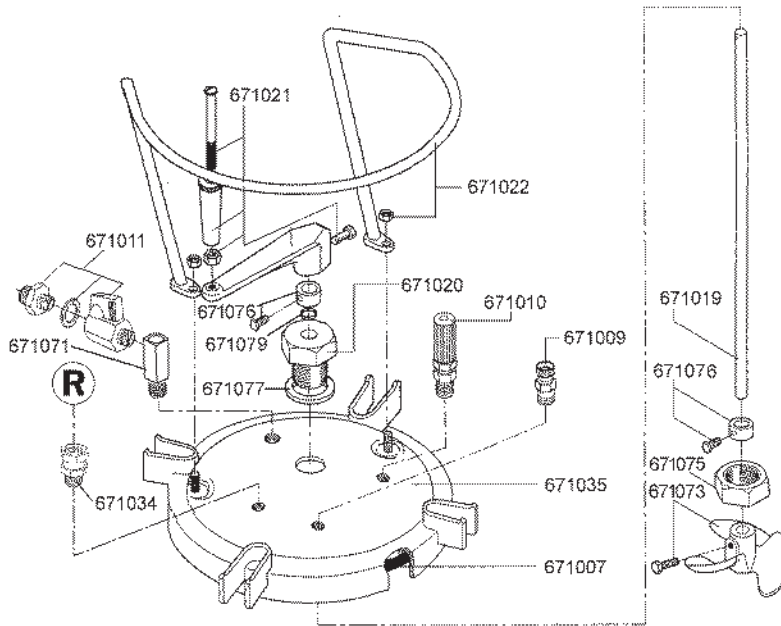

Pneumatic Air Agitator Version

671045A 10 Liter deck, W/air agitator, W/O regulator, (includes everything shown below)

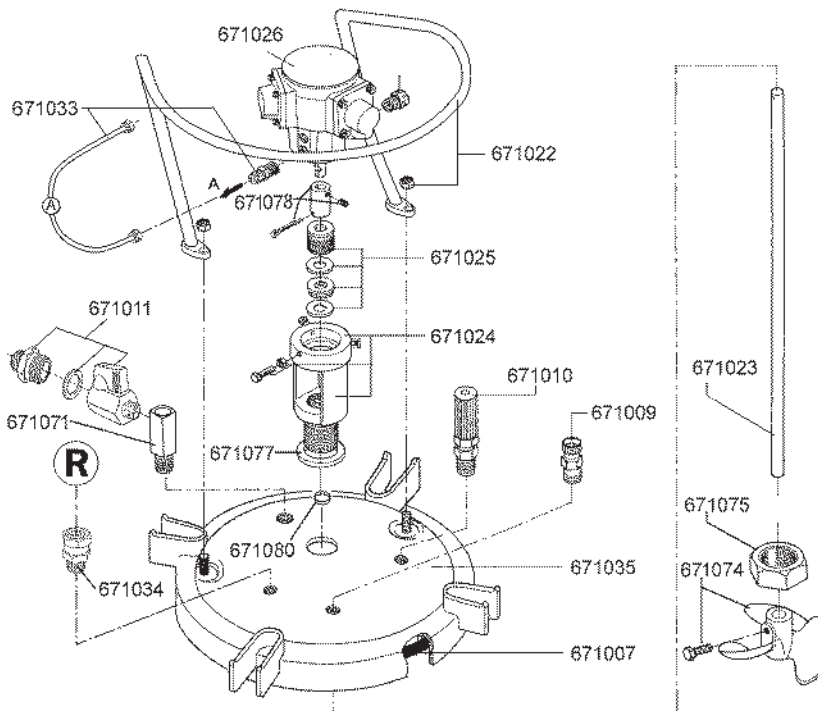

Spare Parts 20 & 40 Liter Pressure Tank Lid

Part No./Descr.	
671002HD	Wheel assembly
671003	Swing bolt assembly
671008	Handle
671009	Pressure relief valve
671010	Secondary over-pressure release valve
671011	Fluid valve assembly
671020	Manual crank base
671021	Manual crank handle
671024	Motor base assemble
671025	Connecting bushing assm.
671026	Air motor
671030	Plug, male
671033	Agitator air line assembly
671034	Swivel connector, male/female
671036	Muffler
671075	Agitator base nut
671076	Manual agitator shaft lock
671077	Agitator base gasket
671078	Pneumatic agitator shaft
671079	O ring, Manual agitator base, (pk of 2)
671080	O ring, Air agitator base, (pk of 2)
672001	Pressure tank, 20-Liter
672002	Fluid tube, 20L
672003	Fluid sieve kit, 20L
672005	Tank lid
672006	Lid gasket
672008	Cap screw
672009	O Ring
672010	Manual agitator shaft, 20-Liter
672011	Parts guard assembly
672012	Disposable liner, 20L Pk of 12
672013	Pneumatic agitator shaft
672024	Disposable liner, 20L Pk of 60
672071	Fluid outlet
672072	Fluid sieve housing
672073	Hand agitator paddle, w/bolt
672074	Pneumatic agitator propeller
674001	Pressure tank, 40-Liter
674002	Fluid tube, 40L
674004	Manual agitator shaft, 40-Liter
674005	Pneumatic agitator shaft, 40L

20 Liter Manual Crank Agitators (20L only)

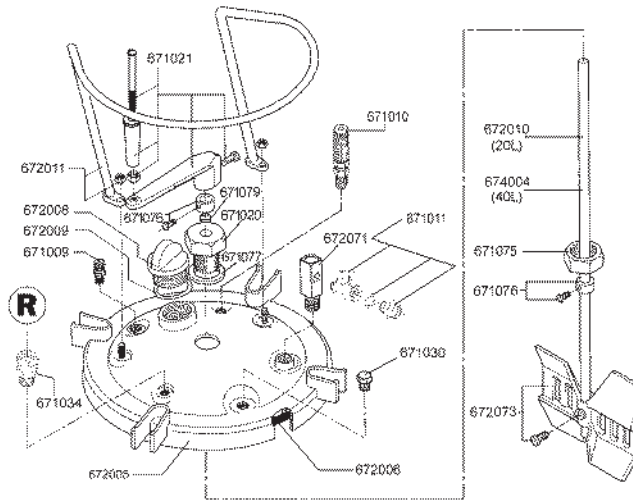

Pneumatic Air Agitator 20L or 40L

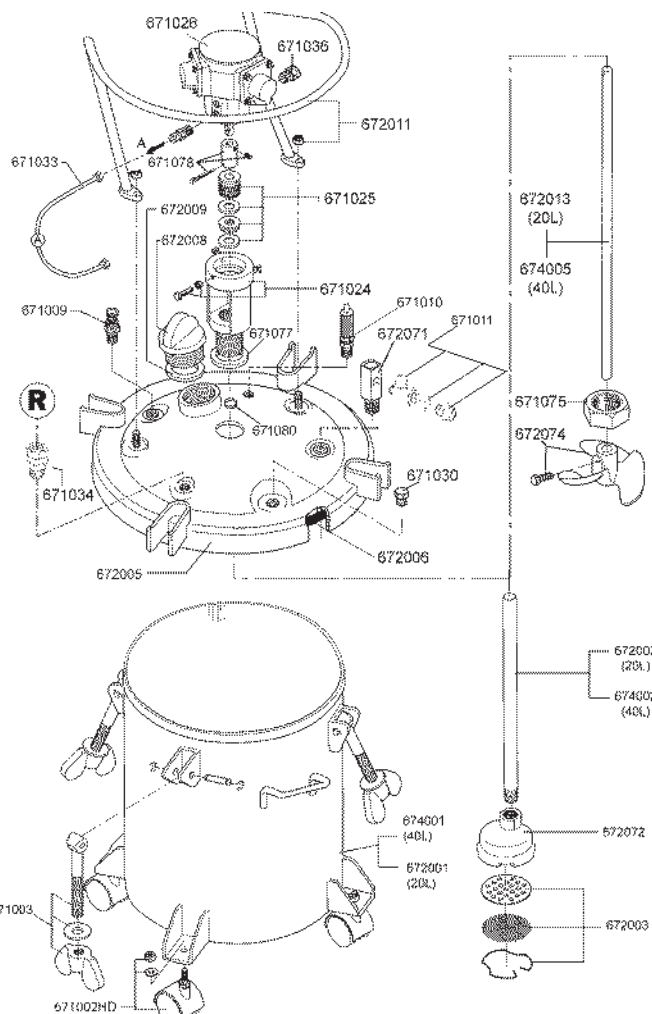

R = Regulator
See page 158, 159

Technical modifications and printing errors reserved

Parts Pressure tank regulators 675640 & 675642

NOTE - As of April 2013, all regulators have a new body style. Older versions are no longer available. In some circumstances, an adapter may be required to fit the new regulators to the old systems.



675640 Single regulator for Std and manual stir tanks, 10, 20, & 40L

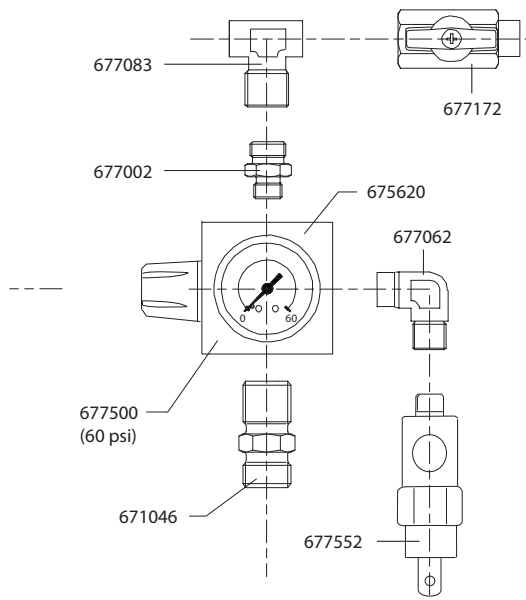

Part No./Descr.	
671046	Check valve
675620	Regulator body, 1/4"
677002	Male hex nipple, 1/4"
677062	Street elbow, 1/8"
677063	Street elbow, 1/4"
677083	Tee fitting, 1/4"
677172	Mini ball valve, 1/4"
677500	Gauge, 1-1/2", 60 PSI
677502	Gauge, 1-1/2", 100 PSI
677552	Over pressure valve, 60psi

675642 Dual regulator for std and manual stir tank

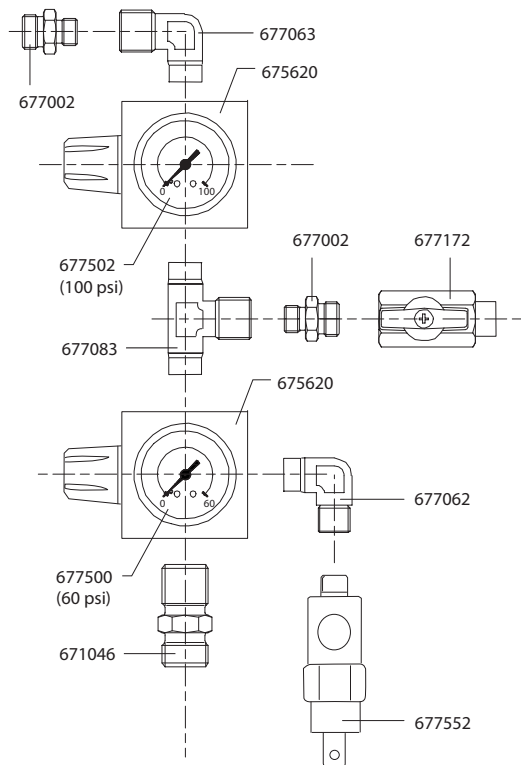

Technical modifications and printing errors reserved

Parts Pressure tank regulators 675644 & 675646

NOTE - As of April 2013, all regulators have a new body style. Older versions are no longer available. In some circumstances, an adapter may be required to fit the new regulators to the old systems.



Part No./Descr.	
671033	Agitator airline assembly (includes hose and fasteners)
671036	Agitator shut off valve
671046	Check valve
675620	Regulator body, 1/4"
677002	Hex nipple, 1/4"
677062	Street elbow, 1/8"
677063	Street elbow, 1/4"
677095	Female cross
677172	Mini ball valve, 1/4"
677500	Gauge, 60 PSI, 1-1/2"
677502	Gauge, 100 PSI, 1-1/2"
677552	Over pressure valve, 60psi



675644 Single regulator for Air Agitated tanks, 10, 20, & 40L

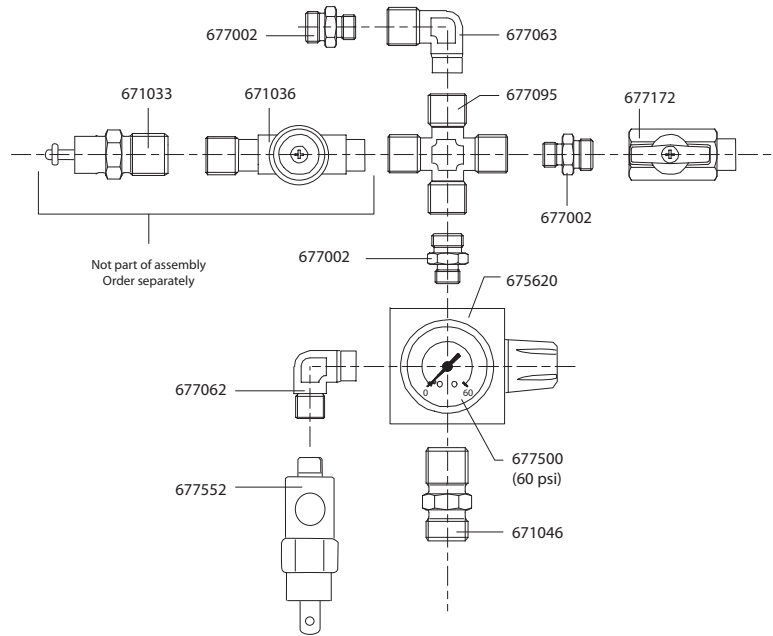

675646 Dual regulator for Air Agitated tanks

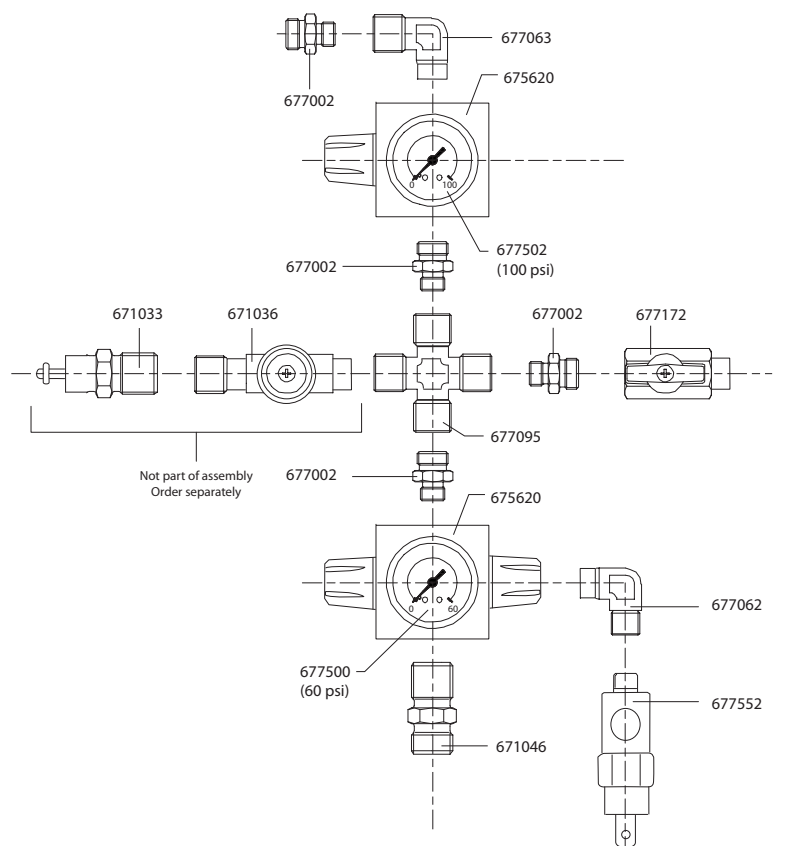









Technical modifications and printing errors reserved

Pro Stencils

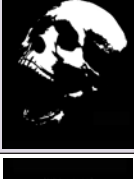

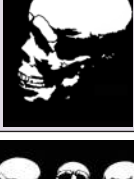

Pro Skull Stencils SERIES 1

Pro Skull stencils are made to PAINT OVER DARK COLORS.

T1	Skull pack 1 Five different sizes	
T2	Skull pack 2 Five different sizes	
T3	Skull pack 3 Five different sizes	
T4	Skull pack 4 Five different sizes	
T5	Skull pack 5 Five different sizes	
T6	Skull pack 6 Five different sizes	
T7	Skull pack 7 Five different sizes	
T8	Super Skull pack This contains 35 stencils. Five different sizes of each., T1, T2, T3, T4, T5, T6, T7	

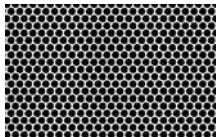
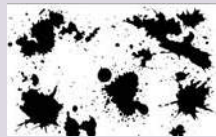
Pro Texture Stencils

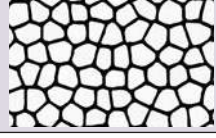
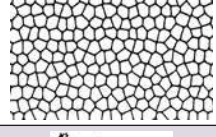
Pro Texture stencils, Each supplied in 2 sizes.

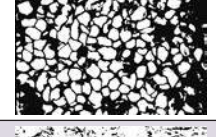
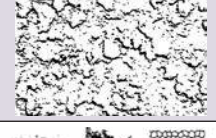
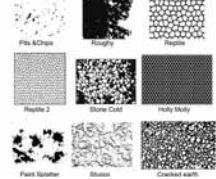
T9	2 Stencils - Cracked Earth, Approx. size 1) 4" x 5" 1) 8" x 10"	
T10	2 Stencils - Holly Molly, approx. size 1) 4" x 5" 1) 8" x 10"	
T11	2 Stencils - Paint Splatter, approx. size 1) 4" x 5" 1) 8" x 10"	
T12	2 Stencils - Pits & Chips, approx. size 1) 4" x 5" 1) 8" x 10"	
T13	2 Stencils - Reptile, approx. size 1) 4" x 5" 1) 8" x 10"	
T14	2 Stencils - Reptile 2, approx. size 1) 4" x 5" 1) 8" x 10"	
T15	2 Stencils - Roughly, approx. size 1) 4" x 5" 1) 8" x 10"	
T16	2 Stencils - Stone Cold, approx. size 1) 4" x 5" 1) 8" x 10"	
T17	2 Stencils - Stucco, approx. size 1) 4" x 5" 1) 8" x 10"	
T18	18 Stencils - Mega Texture Kit, One SET of each; T9, T10, T11, T12, T13, T14, T15, T16, T17	

Pro Stencils

Freehand stencils

Dan-Am Pro freehand stencils and paint masking paper

T19

Necessary Nine,
handheld stencil kit



Paint Masking

MH4075

Sticky Mickey's
Original paint masking paper.

10" x 150'



SATA Premium Warranty



Terms for SATA Premium Warranty:

All SATA equipment comes complete with a 1 year built in warranty. In addition you will be granted for SATA paint spray guns, filters or air fed respirators a prolonged 2 year warranty period free of charge (1 year + 2 years = 3 years). To qualify for the extended warranty, please fill out the extended warranty form online at www.satacanada.com within thirty (30) days of purchasing date. Alternatively, there is a Premium Warranty

Form included in all applicable packaging that can be filled out and sent to SATA with proof of purchase.

SATA guarantees that the equipment supplied is free from material and production defaults. The Premium Warranty is valid under the condition that the equipment is used and handled correctly in accordance with the SATA operating instructions.

The Premium Warranty covers the expenses for repair and free of charge replacement of defective parts featuring material or production defaults; further claims are excluded as far as there is no legally compulsory liability.

The Premium Warranty does not cover wear-and-tear parts in particular (e.g. nozzle sets, filters, packings, diaphragms, springs), normal wear, electronic components and overstressing. Performance of warranty acts does neither cause a prolongation of the warranty period, nor does it initiate a new warranty period. Claims may only be recognized in cases where the equipment is sent pre-paid delivery, assembled and in its original state, to the supplier or the SATA Importer, [Eurotech Spray Products Ltd.] along with copies of the Premium Warranty inscription or email confirmation as well as the proof of purchase.

We believe you will agree that the painter is ultimately responsible for the maintenance and mechanical condition of their spray gun

Warranty work excludes the following:

1. Internal or external cleaning of the spray gun or any party thereof. On warranty claims, your spray gun must be received in clean condition, ready for testing. There will be a \$30.00 charge if your gun is not in testable condition upon arriving in our shop
2. Damage to any nozzle component caused by vise-grips, pliers, nails, wire or any other foreign object
3. Damage caused by dropping the spray gun or any other nozzle component
4. Damage caused by the use of abrasive materials
5. Damages caused by improper handling, normal wear and tear, mechanical damage, faulty assembly, and improper maintenance

Eurotech Repair Order Form

All equipment in need of general repair or warranty repair, must be accompanied by a 'Repair Order Form', issued by Eurotech, and filled out by the customer. Warranty is only granted in-house by Eurotech trained technicians, no exceptions apply.

All repairs, upon arrival at Eurotech, are inspected and diagnosed. A quote is prepared and sent to customer with diagnostics and a purchase order request. Note - no repairs are done without express authorization from the customer.

All repairs must be shipped, freight-paid to Eurotech, in compliance with Eurotech's return policies. Proof of purchase date, along with registered extended warranty card, (when/if applicable) must accompany all equipment sent in for warranty work. If customer cannot prove purchase date and/or proof of extended warranty registration, warranty work will not be granted.

Repair Order Form

Gun Owner Information:

Name _____

Phone _____

Email _____

Contact for Payment or Queries?

Yes

No

Distributor/Jobber Information:

Name _____

Phone _____

Email _____

Contact for Payment or Queries?

Yes

No

Gun Information:

Model _____

HVLP/RP _____

Nozzle Size _____

Serial # _____

Included accessories:

Describe Problem with gun:

Estimate Required?

Yes

No

Eurotech Spray Products Ltd.

Exclusive, independent importer and distributor of SATA products in Canada



3636 Burnsland Rd SE
Calgary Alberta T2G 3Z2

P 800.884.SATA (7282)
P 403.287.3678

F 800.273.SATA (7282)
F 403.287.3724

www.satacanada.com
sales@satacanada.com